

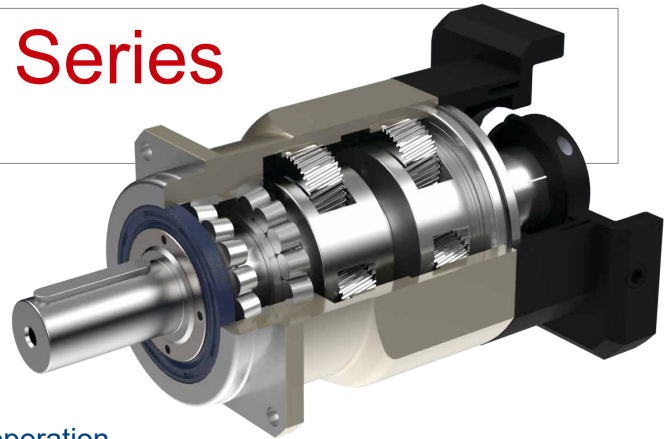

SERVOBOX Planetary Reducers

Characteristic of SF Series

SF



Quiet operation

Helical gears contribute to reduce vibration and noise.

High precision

Backlash ≤ 1 arc-min reaches precision alignment.

High rigidity & torque

High rigidity & high torque are achieved by integrant needle roller bearings and one-piece constructed.

High Load-Bearing Capacity

High load-bearing capacity are achieved by dual taper bearing.

Indication of Model Numbers

SF	142	10	<input type="checkbox"/>	P1	MOTOR
Type	Model	Ratio	Output Bearing	Backlash Class	Motor Type
SF	62	1-Stage	<input type="checkbox"/>	Ps	Motor Brand & Model No.
SF-A	75	3, 4, 5, 6, 7, 8, 9, 10	Standard (Keyway)	P0	
SFL	100			P1	
SFL-A	142	2-Stage 15	N:	P2	
	180	~ 100	Solid Output Shaft (No Keyway)		



Features of SF Series

SF



One-piece Helical Gear Box

The gear box and internal ring gear are one-piece constructed. The speed reduction mechanism employs helical gears, which provides two times meshing rate of teeth when comparing with regular spur gears. In addition, it also has features of extremely smooth running, low noise, high output torque and low backlash.



Full Needle Roller Bearings Design

The planetary gear transmission employs full needle roller bearings without retainer to increase the contact surface, which greatly upgrades structural rigidity and service life.



Collet Locking Mechanism

The input-end and the motor are coupled through a collet locking mechanism. It has passed dynamical balance analysis to assure concentricity and balance on the connection and no backlash for power transmission while running at high speed.

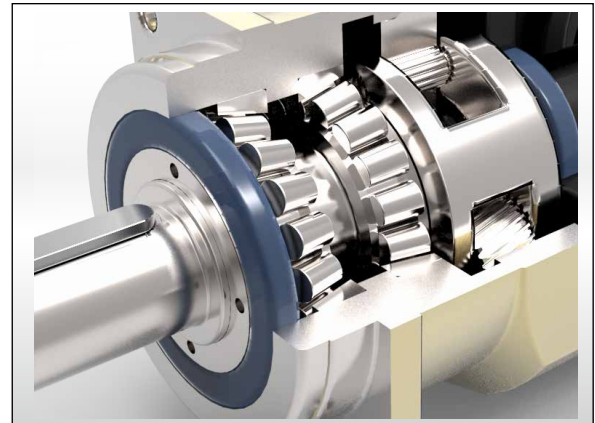

Integrated Planetary Arm Bracket

The planetary arm bracket and the output shaft are one-piece constructed to increase torsional rigidity and accuracy.

SF

SERVOBOX Planetary Reducers

MODEL : SF

1-Stage

RATIO : 3, 4, 5, 6, 7, 8, 9, 10

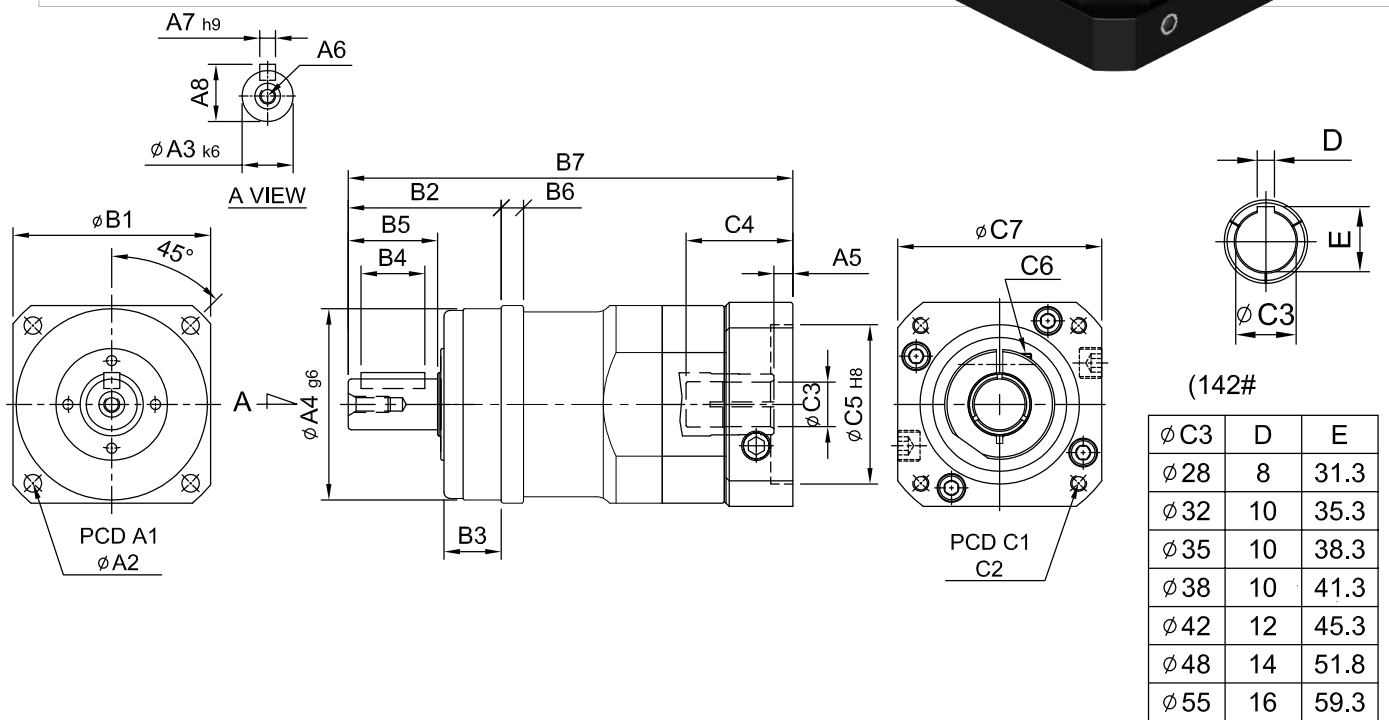

unit: mm

	Model Code	Model				
		62	75	100	142	180
A	A1	68	85	120	165	215
	A2	5.5	6.8	9	11	13
	A3	16	22	32	40	55
	A4	60	70	90	130	160
	A5	6	9.2	10.5	10	11.5 · 13.5
	A6	M5 x P0.8	M8 x P1.25	M10 x P1.5	M12 x P1.75	M14 x P2.0
	A7	5	6	10	12	16
	A8	18	24.5	35	43	59
B	B1	62	76	106	142	180
	B2	48	56	88	112	112
	B3	18	18	27	27	26
	B4	20	32	50	70	70
	B5	28	36	58	82	82
	B6	6	7	10	12	15
	B7	139.5 · 147.5	191	242.5	306	360 · 362
C	C1	70 · 75 · 90	90 · 110 · 115 · 145	115 · 145 · 165	145 · 165 · 215	200 · 215 · 265
	C2	M4 · M5 · M6	M5 · M6 · M8	M6 · M8 · M10	M8 · M10 · M12	M10 · M12 · M16
	C3	11 · 14 · 16 · 19	16 · 19 · 22 · 24	24 · 28 · 32 · 35	28 · 32 · 35 · 38	35 · 38 · 42 · 48 · 55
	C4	33.5	59.2	67.5	84.5	114.5 · 116.5
	C5	50 · 60 · 70	70 · 80 · 95 · 110	95 · 110 · 130	110 · 130 · 180	114.3 · 180 · 230
	C6	M5 x P0.8	M6 x P1.0	M8 x P1.25	M10 x P1.5	M10 x P1.5
	C7	64 · 70 · 80	92 · 110 · 130	122 · 130 · 150	146 · 150 · 190	182 · 200 · 250



High Precision Planetary Reducer

Model No.		Unit	Ratio	62	75	100	142	180
Rated Output Torque (Nominal output torque)	T_{2N}	Nm	3	59	165	216	625	1,206
			4	51	146	208	555	1,069
			5	48	155	333	618	1,189
			6	45	150	315	583	1,118
			7	45	142	309	573	1,108
			8	43	141	305	553	1,070
			9	44	140	293	516	993
	10	43	136	294	549	1,059		
Max. Acceleration Torque	T_{2B}	Nm	3 ~ 10	1.8 Times of Rated Output Torque				
Max. Output Torque Emergency Stop Torque	T_{2NOT}	Nm	3 ~ 10	3 Times of Rated Output Torque				
Rated Input Speed	n_{1N}	rpm	3 ~ 10	3,000	3,000	3,000	3,000	3,000
Max. Input Speed	n_{1B}	rpm	3 ~ 10	6,000	6,000	6,000	5,000	4,000
Backlash Ps		arcmin	3 ~ 10	-	≤ 1	≤ 1	≤ 1	≤ 1
Backlash P0		arcmin	3 ~ 10	≤ 3	≤ 3	≤ 3	≤ 3	≤ 3
Backlash P1		arcmin	3 ~ 10	≤ 5	≤ 5	≤ 5	≤ 5	≤ 5
Backlash P2		arcmin	3 ~ 10	≤ 7	≤ 7	≤ 7	≤ 7	≤ 7
Torsional Rigidity		Nm/arcmin	3 ~ 10	8	15	27	60	150
Max. Radial Force	F_{2rB}	N	3 ~ 10	2,240	4,150	8,760	12,750	17,860
Max. Axial Force	F_{2aB}	N	3 ~ 10	1,920	3,780	7,500	10,840	15,180
Service Life	L_H	hr	3 ~ 10	S5 Cycle Operation: >30,000 (S1 Continuous Operation: >15,000 hrs)				
Efficiency	η	%	3 ~ 10	≥ 97%				
Operating Temperature		°C	3 ~ 10	- 25° C ~ + 90° C				
Lubrication			3 ~ 10	Synthetic Grease				
Protection Class			3 ~ 10	IP65				
Mounting Position			3 ~ 10	Any				
Noise Level		dB	3 ~ 10	≤ 58	≤ 60	≤ 63	≤ 65	≤ 67
Weight ±3%		Kg	3 ~ 10	1.7	4.5	8.3	16.7	34.3

■ Mass Moments of Inertia (kg.cm²)

Ratio	62	75	100	142	180
3	0.15	0.60	3.21	9.18	28.82
4	0.14	0.51	2.80	7.51	23.56
5	0.13	0.45	2.71	7.40	23.74
6	0.13	0.45	2.65	7.15	22.65
7	0.12	0.42	2.54	7.15	22.40
8	0.12	0.42	2.51	7.01	22.35
9	0.12	0.42	2.51	7.01	22.35
10	0.12	0.42	2.51	7.01	22.35

SF

SERVOBOX Planetary Reducers

MODEL : SF

2-Stage

RATIO : 15, 20, 25, 30, 35, 40, 50, 60, 70, 80, 90, 100

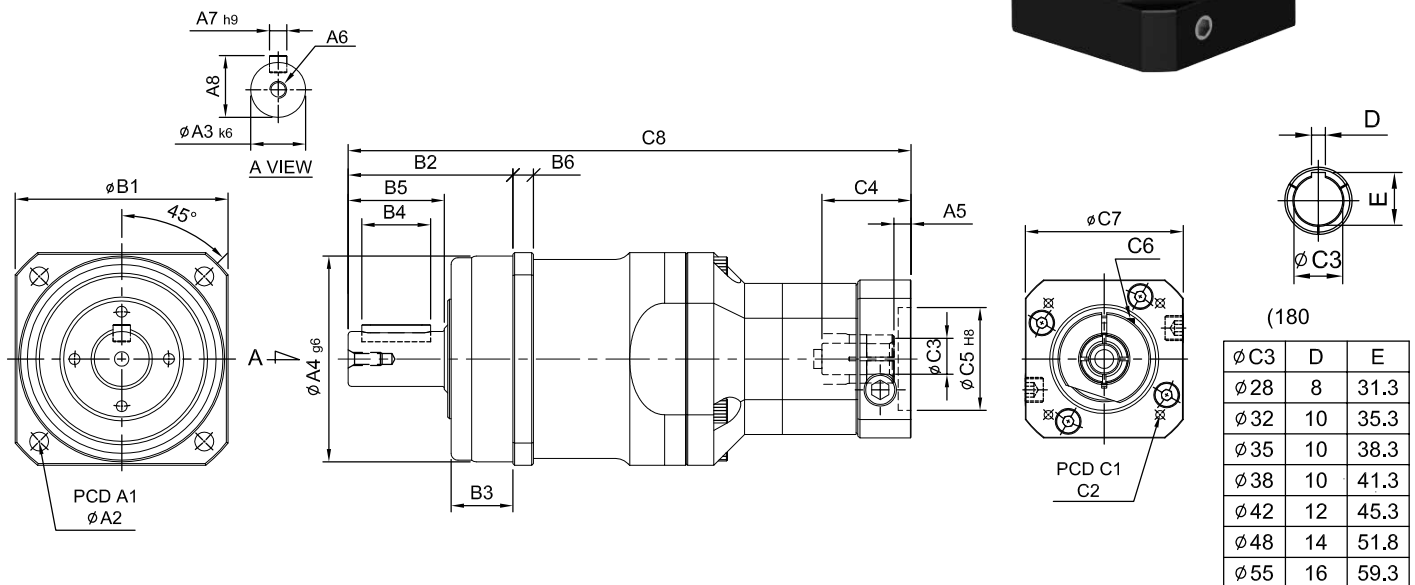

SF

unit: mm

Model Code	62	75	100	142	180
A					
A1	68	85	120	165	215
A2	5.5	6.8	9	11	13
A3	16	22	32	40	55
A4	60	70	90	130	160
A5	5	6	9	10	10
A6	M5 x P0.8	M8 x P1.25	M10 x P1.5	M12 x P1.75	M14 x P2.0
A7	5	6	10	12	16
A8	18	24.5	35	43	59
B					
B1	62	76	106	142	180
B2	48	56	88	112	112
B3	18	18	27	27	26
B4	20	32	50	70	70
B5	28	36	58	82	82
B6	6	7	10	12	15
C					
C1	46 · 60 · 63	70 · 75 · 90	90 · 110 · 115 · 145	115 · 145 · 165	145 · 165 · 215
C2	M3 · M4 · M5	M4 · M5 · M6	M5 · M6 · M8	M6 · M8 · M10	M8 · M10 · M12
C3	8 · 9 · 11	11 · 14 · 16 · 19	16 · 19 · 22 · 24	22 · 24 · 28 · 32	28 · 32 · 35 · 38
C4	26	33.5	59	67	84.5
C5	30 · 40 · 50	50 · 60 · 70	70 · 80 · 95 · 110	95 · 110 · 130	110 · 130 · 180
C6	M4 x P0.7	M5 x P0.8	M6 x P1.0	M8 x P1.25	M10 x P1.5
C7	46 · 55	64 · 70 · 80	92 · 110 · 130	122 · 130 · 150	146 · 150 · 190
C8	164	198.8 · 206.8	278	344	395

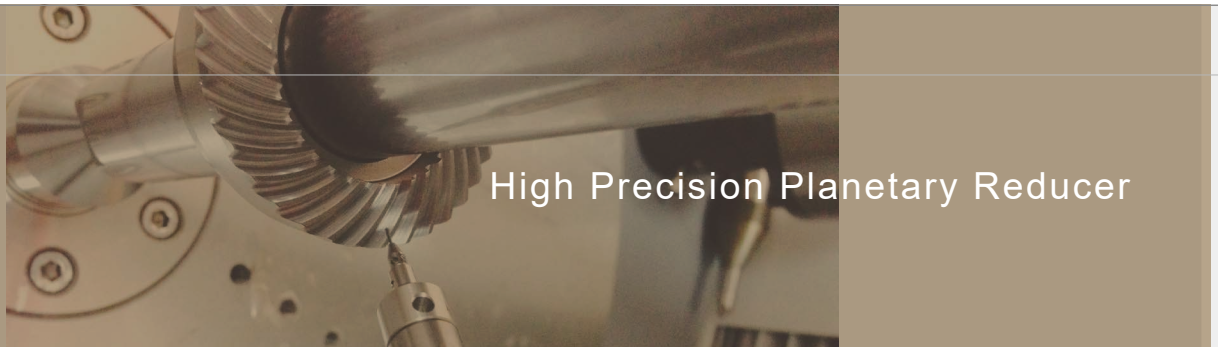

High Precision Planetary Reducer

Model No.		Unit	Ratio	62	75	100	142	180
Rated Output Torque (Nominal output torque)	T_{2N}	Nm	15	59	165	216	625	1,206
			20	51	146	208	555	1,069
			25	48	155	333	618	1,189
			30	45	150	315	583	1,118
			35	45	142	309	573	1,108
			40	51	146	208	555	1,070
			50	48	155	333	618	1,189
			60	45	150	315	583	1,118
			70	45	142	309	573	1,108
			80	43	141	305	553	1,070
			90	44	140	293	516	993
100	43	136	294	549	1,059			
Max. Acceleration Torque	T_{2B}	Nm	15 ~ 100	1.8 Times of Rated Output Torque				
Max. Output Torque Emergency Stop Torque	T_{2NOT}	Nm	15 ~ 100	3 Times of Rated Output Torque				
Rated Input Speed	n_{1N}	rpm	15 ~ 100	3,000	3,000	3,000	3,000	3,000
Max. Input Speed	n_{1B}	rpm	15 ~ 100	6,000	6,000	5,000	5,000	4,000
Backlash Ps		arcmin	15 ~ 100	-	-	≤ 3	≤ 3	≤ 3
Backlash P0		arcmin	15 ~ 100	≤ 5	≤ 5	≤ 5	≤ 5	≤ 5
Backlash P1		arcmin	15 ~ 100	≤ 7	≤ 7	≤ 7	≤ 7	≤ 7
Backlash P2		arcmin	15 ~ 100	≤ 9	≤ 9	≤ 9	≤ 9	≤ 9
Torsional Rigidity		Nm/arcmin	15 ~ 100	8	15	27	60	140
Max. Radial Force	F_{2rB}	N	15 ~ 100	2,240	4,150	8,760	12,750	17,860
Max. Axial Force	F_{2aB}	N	15 ~ 100	1,920	3,780	7,500	10,840	15,180
Service Life	L_H	hr	15 ~ 100	S5 Cycle Operation: >30,000 (S1 Continuous Operation: >15,000 hrs)				
Efficiency	η	%	15 ~ 100	≥ 94%				
Operating Temperature		°C	15 ~ 100	- 25° C ~ + 90° C				
Lubrication			15 ~ 100	Synthetic Grease				
Protection Class			15 ~ 100	IP65				
Mounting Position			15 ~ 100	Any				
Noise Level		dB	15 ~ 100	≤ 58	≤ 60	≤ 63	≤ 65	≤ 67
Weight ±3%		Kg	15 ~ 100	2.52	4.8	8.48	19.98	37.3

■ Mass Moments of Inertia (kg.cm²)

Ratio	62	75	100	142	180
15	0.03	0.13	0.47	2.63	7.30
20	0.03	0.13	0.47	2.63	7.30
25	0.03	0.13	0.47	2.63	7.10
30	0.03	0.13	0.47	2.43	7.10
35	0.03	0.13	0.47	2.43	7.10
40	0.03	0.13	0.47	2.43	6.92
50	0.03	0.13	0.44	2.43	6.92
60	0.03	0.13	0.44	2.39	6.72
70	0.03	0.13	0.44	2.39	6.72
80	0.03	0.13	0.44	2.39	6.72
90	0.03	0.13	0.44	2.39	6.72
100	0.03	0.13	0.44	2.39	6.72

SERVOBOX Planetary Reducers



MODEL : SF-A

2-Stage

RATIO : 15, 20, 25, 30, 35, 40, 50, 70, 100

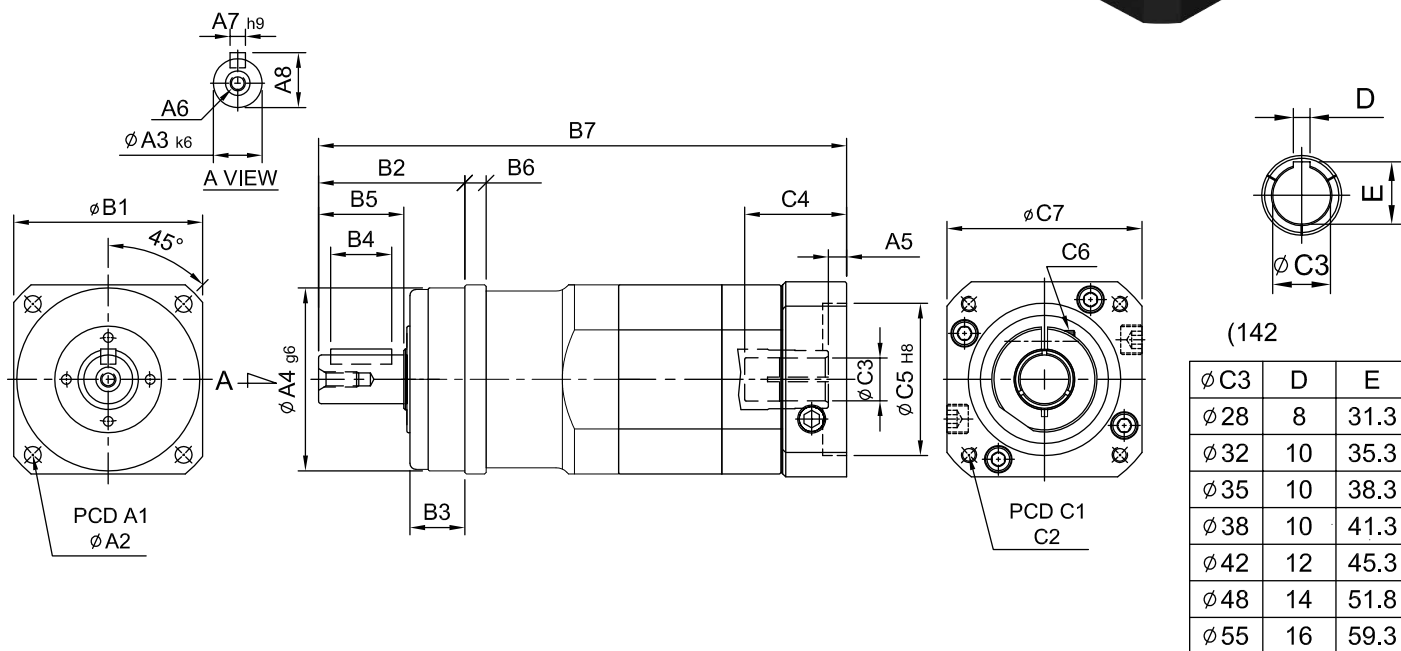

unit: mm

Model Code	unit: mm					
	62A	75A	100A	142A	180A	
A	A1	68	85	120	165	215
	A2	5.5	6.8	9	11	13
	A3	16	22	32	40	55
	A4	60	70	90	130	160
	A5	6	8	10.5	10	11.5 · 13.5
	A6	M5 x P0.8	M8 x P1.25	M10 x P1.5	M12 x P1.75	M14 x P2.0
	A7	5	6	10	12	16
	A8	18	24.5	35	43	59
B	B1	62	76	106	142	180
	B2	48	56	88	112	112
	B3	18	18	27	27	26
	B4	20	32	50	70	70
	B5	28	36	58	82	82
	B6	6	7	10	12	15
	B7	173.3 · 181.3	214	282.5	373	441 · 443
C	C1	70 · 75 · 90	90 · 110 · 115 · 145	115 · 145 · 165	145 · 165 · 215	200 · 215 · 265
	C2	M4 · M5 · M6	M5 · M6 · M8	M6 · M8 · M10	M8 · M10 · M12	M10 · M12 · M16
	C3	11 · 14 · 16 · 19	16 · 19 · 22 · 24	24 · 28 · 32	28 · 32 · 35 · 38	35 · 38 · 42 · 48 · 55
	C4	33.5	51	67.5	84.5	114.5 · 116.5
	C5	50 · 60 · 70	70 · 80 · 95 · 110	95 · 110 · 130	110 · 130 · 180	114.3 · 180 · 230
	C6	M5 x P0.8	M6 x P1.0	M8 x P1.25	M10 x P1.5	M10 x P1.5
	C7	64 · 70 · 80	92 · 110 · 130	122 · 130 · 150	146 · 150 · 190	182 · 200 · 250



High Precision Planetary Reducer

Model No.		Unit	Ratio	62A	75A	100A	142A	180A
Rated Output Torque (Nominal output torque)	T_{2N}	Nm	15	59	165	216	625	1,206
			20	51	146	208	555	1,069
			25	48	155	333	618	1,189
			30	45	150	315	583	1,118
			35	45	142	309	573	1,108
			40	51	146	208	555	1,069
			50	48	155	333	618	1,189
			70	45	142	309	573	1,108
	100	43	136	294	549	1,059		
Max. Acceleration Torque	T_{2B}	Nm	15 ~ 100	1.8 Times of Rated Output Torque				
Max. Output Torque Emergency Stop Torque	T_{2NOT}	Nm	15 ~ 100	3 Times of Rated Output Torque				
Rated Input Speed	n_{1N}	rpm	15 ~ 100	3,000	3,000	3,000	3,000	3,000
Max. Input Speed	n_{1B}	rpm	15 ~ 100	6,000	6,000	5,000	5,000	4,000
Backlash Ps		arcmin	15 ~ 100	-	≤ 3	≤ 3	≤ 3	≤ 3
Backlash P0		arcmin	15 ~ 100	≤ 5	≤ 5	≤ 5	≤ 5	≤ 5
Backlash P1		arcmin	15 ~ 100	≤ 7	≤ 7	≤ 7	≤ 7	≤ 7
Backlash P2		arcmin	15 ~ 100	≤ 9	≤ 9	≤ 9	≤ 9	≤ 9
Torsional Rigidity		Nm/arcmin	15 ~ 100	8	15	27	60	140
Max. Radial Force	F_{2rB}	N	15 ~ 100	2,240	4,150	8,760	12,750	17,860
Max. Axial Force	F_{2aB}	N	15 ~ 100	1,920	3,780	7,500	10,840	15,180
Service Life	L_H	hr	15 ~ 100	S5 Cycle Operation: >30,000 (S1 Continuous Operation: >15,000 hrs)				
Efficiency	η	%	15 ~ 100	≥ 94%				
Operating Temperature		°C	15 ~ 100	- 25° C ~ + 90° C				
Lubrication			15 ~ 100	Synthetic Grease				
Protection Class			15 ~ 100	IP65				
Mounting Position			15 ~ 100	Any				
Noise Level		dB	15 ~ 100	≤ 58	≤ 60	≤ 63	≤ 65	≤ 67
Weight ±3%		Kg	15 ~ 100	2.6	8.2	11.5	25.6	43

■ Mass Moments of Inertia (kg.cm²)

Ratio	62A	75A	100A	142A	180A
15	0.15	0.60	3.21	9.18	28.82
20	0.14	0.51	2.80	7.51	23.56
25	0.13	0.45	2.71	7.40	23.24
30	0.15	0.60	3.21	9.18	28.82
35	0.12	0.42	2.54	7.15	22.40
40	0.14	0.51	2.80	7.51	23.56
50	0.13	0.45	2.71	7.40	23.24
70	0.12	0.42	2.54	7.15	22.40
100	0.12	0.42	2.51	7.01	22.35