

HF series

HF

Indication of Model Numbers

HF	60	F	O	B	3	P0	
Type	Model	Input	Output	Bearing	Ratio	Backlash Class	Motor Type
HF	60 75 100 140 180	F : Input Flange	O: Hollow Output Shaft N: Single Clamping (Keyway) N1: Single Clamping (No Keyway) M: Double Clamping S: Single Output Shaft (Keyway) S1: Single Output Shaft (No Keyway)	B : Ball Bearing	5 10 15	P0 ≤ 3 P1 ≤ 6 P2 ≤ 9	



Characteristic of HF Series

HF

1-Stage

Model No.		Unit	Ratio	60	75	100	140	180
/ Rated Output Torque (Nominal output torque)	T_{2N}	Nm	5	30	35	70	260	720
			10	25	30	60	220	615
			15	20	25	50	180	510
/ Max. Acceleration Torque	T_{2B}	Nm	5~15	1.5 Times of Rated Output Torque				
/ Max. Output Torque / Emergency Stop Torque	T_{2NOT}	Nm	5~15	3 Times of Rated Output Torque				
/ Rated Input Speed	n_{1N}	rpm	5	2,200	2,100	1,800	1,150	700
			10	3,300	3,200	2,700	1,800	1,200
			15	4,000	3,900	3,300	2,300	1,600
/ Max. Input Speed	n_{1B}	rpm	5~15	6,000	5,000	4,000	3,000	3,000
/ Backlash	J_t	arcmin	P0	≤ 3	≤ 3	≤ 3	≤ 3	≤ 3
			P1	≤ 6	≤ 6	≤ 6	≤ 6	≤ 6
			P2	≤ 9	≤ 9	≤ 9	≤ 9	≤ 9
/ Max. Radial Force Ball Bearing	F_{2rB}	N	5~15	1,040	1,495	2,366	5,837	7,020
/ Max. Axial Force Ball Bearing	F_{2aB}	N	5~15	520	748	1,183	2,919	3,510
/ Service Life	L_H	hr	5~15	S5 Cycle Operation: >30,000 (S1 Continuous Operation: >15,000 hrs)				
/ Efficiency	η	%	5~8	≥ 96%				
			10~15	≥ 93%				
/ Operating Temperature		°C	5~15	-10°C ~ +90°C				
/ Lubrication			5~15	Synthetic Oil				
/ Noise Level		dB	5~15	≤ 66	≤ 66	≤ 66	≤ 68	≤ 70

Mass Moments of Inertia (kgcm²)

Ratio	60	75	100	140	180
5	0.23	0.23	0.58	4.00	13.53
10	0.15	0.15	0.38	2.46	7.38
15	0.13	0.13	0.34	2.07	5.76

HF-FO series

RATIO : 5.10.15 (1-Stage)



Input Flange - Hollow Output Shaft

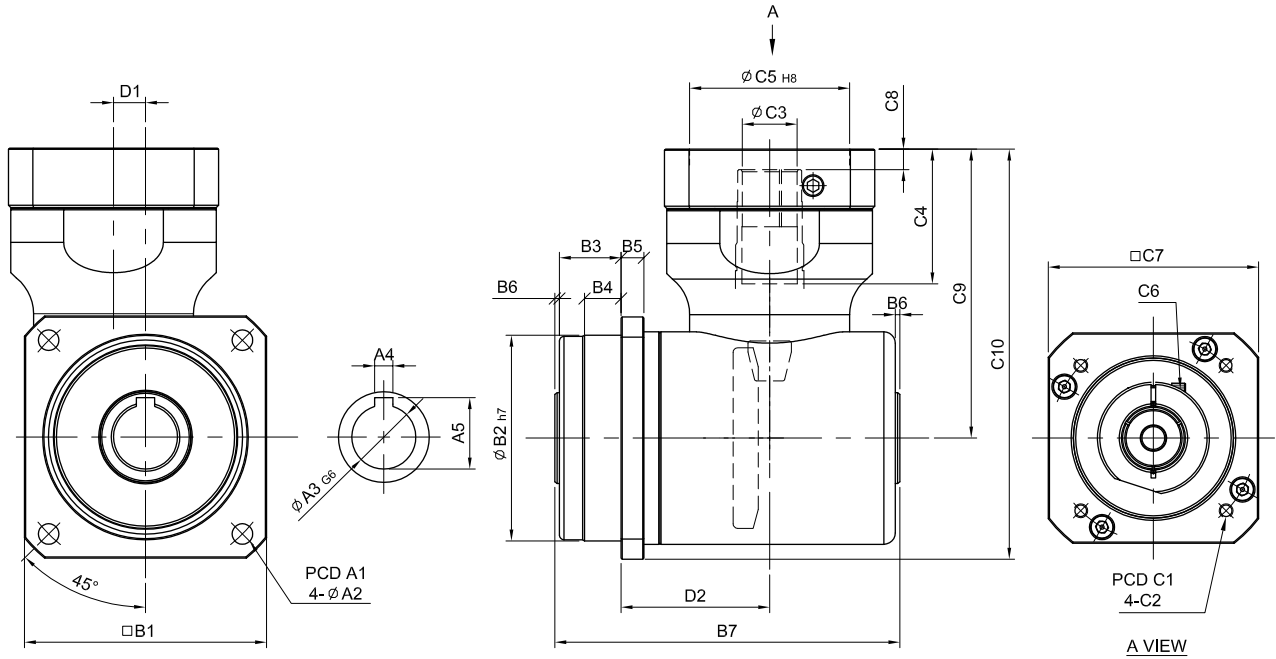

unit: mm

	Model	60	75	100	140	180
	Code					
A	A1	68	85	120	165	215
	A2	5.5	6.5	9	11	13
	A3	15	20	28	40	55
	A4	4	5	8	12	14
	A5	16.7	22.3	31.3	43.3	58.8
B	B1	62	76	106	142	190
	B2	60	70	90	130	160
	B3	18	18	27	27	26
	B4	11	12	16	15.5	15.5
	B5	6	7	10	12	15
	B6	2	2	2	3	3
	B7	103	113	151	193	247
C	C1	46 · 60 · 63	70 · 75 · 90	90 · 100 · 115 · 145	115 · 145 · 165	145 · 165 · 200
	C2	M3 · M4 · M5	M4 · M5 · M6	M5 · M6 · M8	M6 · M8 · M10	M8 · M10 · M12
	C3	11	14	24	35	42
	C4	26	33	59	82	84.5
	C5	30 · 40 · 50	50 · 60 · 70	70 · 80 · 95 · 110	95 · 110 · 130	110 · 130 · 180
	C6	M4 x P0.7	M5 x P0.8	M6 x P1.0	M8 x P1.25	M10 x P1.5
	C7	46 · 55	64 · 70 · 80	92 · 110 · 130	122 · 130 · 150	146 · 150 · 190
	C8	5	6	9	10	10
	C9	69	95.5	126.5	179	228
	C10	100	133.5	179.5	250	323
D	D1	9	9	14	23	32
	D2	41.5	48	65	90	125
Weight						

HF-FN series

RATIO : 5.10.15 (1-Stage)



Input Flange - Single Clamping

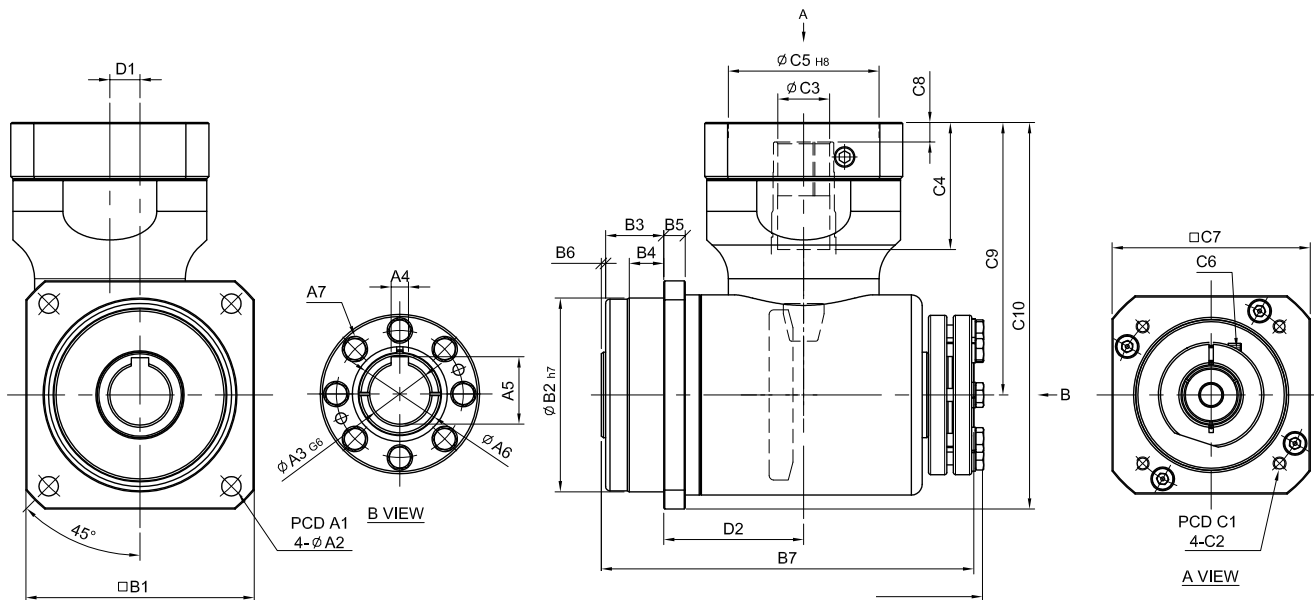

unit: mm

Model Code	60	75	100	140	180	
A	A1	68	85	120	165	215
	A2	5.5	6.5	9	11	13
	A3	15	20	28	40	55
	A4	4	5	8	12	14
	A5	16.7	22.3	31.3	43.3	58.8
	A6	22	28	38	52	73
	A7	6-M6	6-M6	8-M6	8-M8	8-M8
B	B1	62	76	106	142	190
	B2	60	70	90	130	160
	B3	18	18	27	27	26
	B4	11	12	16	15.5	15.5
	B5	6	7	10	12	15
	B6	2	2	2	3	3
	B7	123.5	134	173	223	279
	B8	127.5	138	177	228	283
C	C1	46 · 60 · 63	70 · 75 · 90	90 · 100 · 115 · 145	115 · 145 · 165	145 · 165 · 200
	C2	M3 · M4 · M5	M4 · M5 · M6	M5 · M6 · M8	M6 · M8 · M10	M8 · M10 · M12
	C3	11	14	24	35	42
	C4	26	33	59	82	84.5
	C5	30 · 40 · 50	50 · 60 · 70	70 · 80 · 95 · 110	95 · 110 · 130	110 · 130 · 180
	C6	M4 x P0.7	M5 x P0.8	M6 x P1.0	M8 x P1.25	M10 x P1.5
	C7	46 · 55	64 · 70 · 80	92 · 110 · 130	122 · 130 · 150	146 · 150 · 190
	C8	5	6	9	10	10
	C9	69	95.5	126.5	179	228
	C10	100	133.5	179.5	250	323
D	D1	9	9	14	23	32
	D2	41.5	48	65	90	125
Weight						

HF-FM series

RATIO : 5.10.15 (1-Stage)



Input Flange - Double Clamping

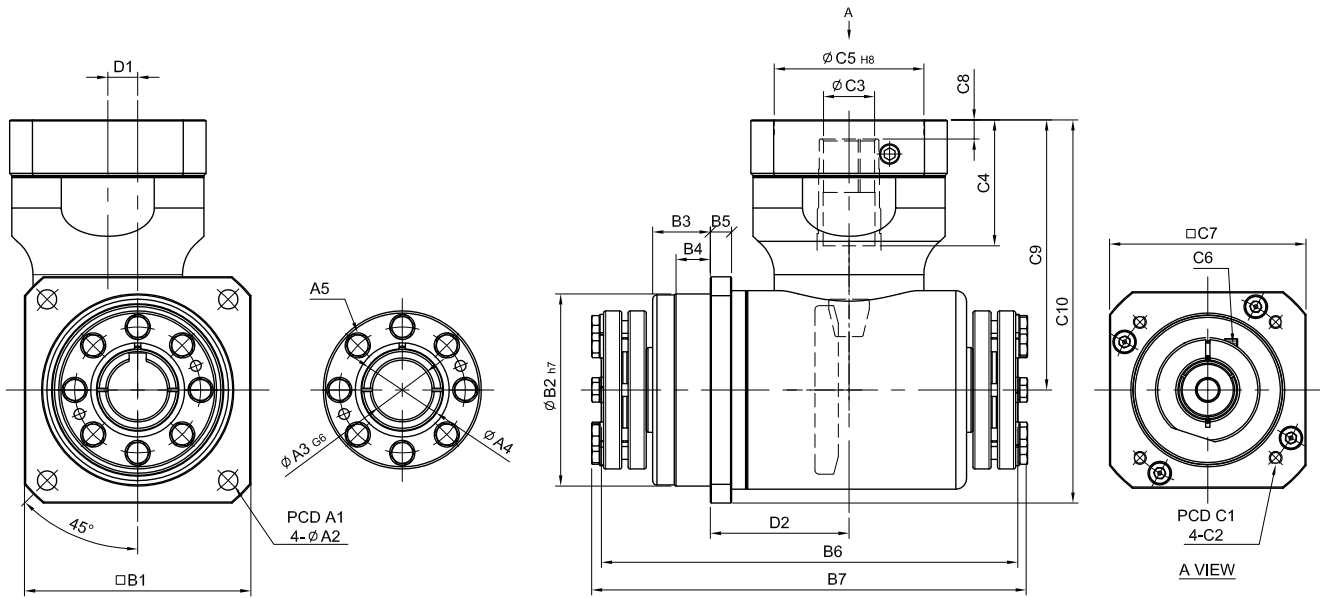

unit: mm

Model Code	60	75	100	140	180	
A	A1	68	85	120	165	215
	A2	5.5	6.5	9	11	13
	A3	15	20	28	40	55
	A4	22	28	38	52	73
	A5	6-M6	6-M6	8-M6	8-M8	8-M8
B	B1	62	76	106	142	190
	B2	60	70	90	130	160
	B3	18	18	27	27	26
	B4	11	12	16	15.5	15.5
	B5	6	7	10	12	15
	B6	144	155	195	253	311
	B7	152	163	203	262	318.5
C	C1	46 · 60 · 63	70 · 75 · 90	90 · 100 · 115 · 145	115 · 145 · 165	145 · 165 · 200
	C2	M3 · M4 · M5	M4 · M5 · M6	M5 · M6 · M8	M6 · M8 · M10	M8 · M10 · M12
	C3	11	14	24	35	42
	C4	26	33	59	82	84.5
	C5	30 · 40 · 50	50 · 60 · 70	70 · 80 · 95 · 110	95 · 110 · 130	110 · 130 · 180
	C6	M4 x P0.7	M5 x P0.8	M6 x P1.0	M8 x P1.25	M10 x P1.5
	C7	46 · 55	64 · 70 · 80	92 · 110 · 130	122 · 130 · 150	146 · 150 · 190
	C8	5	6	9	10	10
	C9	69	95.5	126.5	179	228
	C10	100	133.5	179.5	250	323
D	D1	9	9	14	23	32
	D2	41.5	48	65	90	125
Weight						

HF-FS series

RATIO : 5.10.15 (1-Stage)

Input Flange - Single Output Shaft

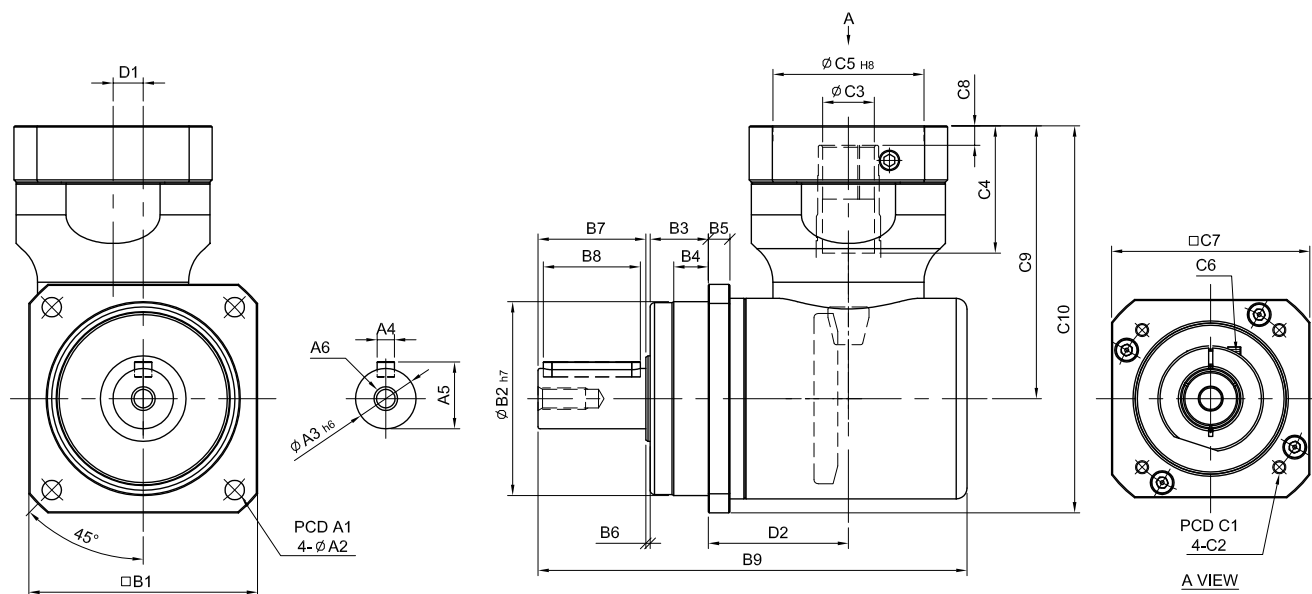

unit: mm

	Model Code	60	75	100	140	180
A	A1	68	85	120	165	215
	A2	5.5	6.5	9	11	13
	A3	16	22	28	40	55
	A4	5	6	8	12	16
	A5	18	24.5	31	43	59
	A6	M5 x P0.8	M8 x P.125	M10 x 1.5	M12 x P1.75	M16 x P20
B	B1	62	76	106	142	190
	B2	60	70	90	130	160
	B3	18	18	27	27	26
	B4	11	12	16	15.5	15.5
	B5	6	7	10	12	15
	B6	2	2	2	3	3
	B7	28	36	50	70	82
	B8	25	32	45	60	70
	B9	129	147	199	260	326
C	C1	46 · 60 · 63	70 · 75 · 90	90 · 100 · 115 · 145	115 · 145 · 165	145 · 165 · 200
	C2	M3 · M4 · M5	M4 · M5 · M6	M5 · M6 · M8	M6 · M8 · M10	M8 · M10 · M12
	C3	11	14	24	35	42
	C4	26	33	59	82	84.5
	C5	30 · 40 · 50	50 · 60 · 70	70 · 80 · 95 · 110	95 · 110 · 130	110 · 130 · 180
	C6	M4 x P0.7	M5 x P0.8	M6 x P1.0	M8 x P1.25	M10 x P1.5
	C7	46 · 55	64 · 70 · 80	92 · 110 · 130	122 · 130 · 150	146 · 150 · 190
	C8	5	6	9	10	10
	C9	69	95.5	126.5	179	228
	C10	100	133.5	179.5	250	323
D	D1	9	9	14	23	32
	D2	41.5	48	65	90	125
Weight						