

RSN

MODEL : RSN6

RATIO : 41、61、81、121

Unit: mm

Model Code	RSN6
A1	70、75、90
A2	M4、M5、M6
A3	50、60、70
A4	64、70、80

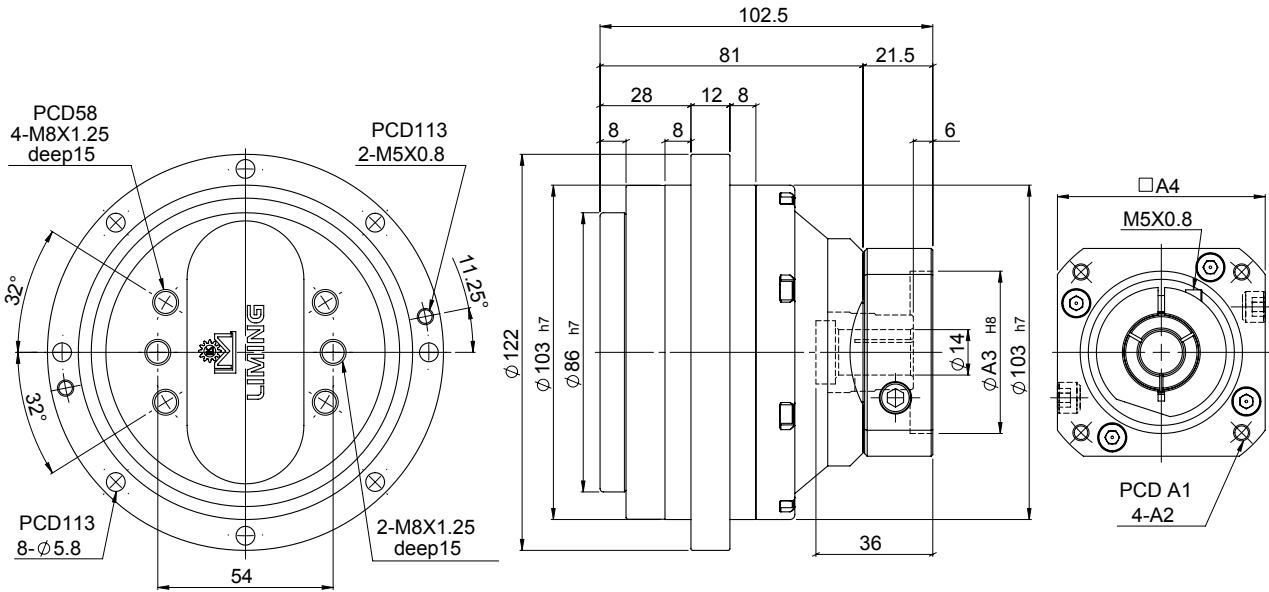

Characteristic		Unit	RSN6
Output Table Supporting Bearing			Angular Contact Ball Bearing
/ Rated Output Torque		Nm	60
/ Max. Output Torque	T_{2NOT}	Nm	5 Time of Rated Output Torque
/ Emergency Stop Torque			
/ Max. Acceleration Torque	T_{2B}	Nm	2 Times of Rated Output Torque
/ Inertia Moment		kg.m ²	1.15×10^{-4}
/ Rated Output Speed		rpm	15
/ Max. Output Speed		rpm	55
/ Permissible Input Speed		rpm	3,000
/ Backlash Ps	J_i	arcmin	≤ 2
/ Backlash P0	J_i	arcmin	≤ 4
/ Backlash P1	J_i	arcmin	≤ 6
/ Max. Radial Force	F_{2rB}	N	2,100
/ Max. Axial Force	F_{2aB}	N	1,500
/ Rated Life	L_H	hr	S5 Cycle Operation: >6,000 (S1 Continuous Operation: >3,000 hrs)
/ Torsional Rigidity		Nm/arcmin	50
/ Efficiency	η	%	≥ 85
/ Synthetic Grease		g	100
/ Weight		kg	3.19

MODEL : RSN20

RATIO : 41、61、81、121、161

Unit: mm

Model Code	RSN20
A1	70、75、90
A2	M4、M5、M6
A3	50、60、70
A4	64、70、80
A5	14、19
A6	36、46

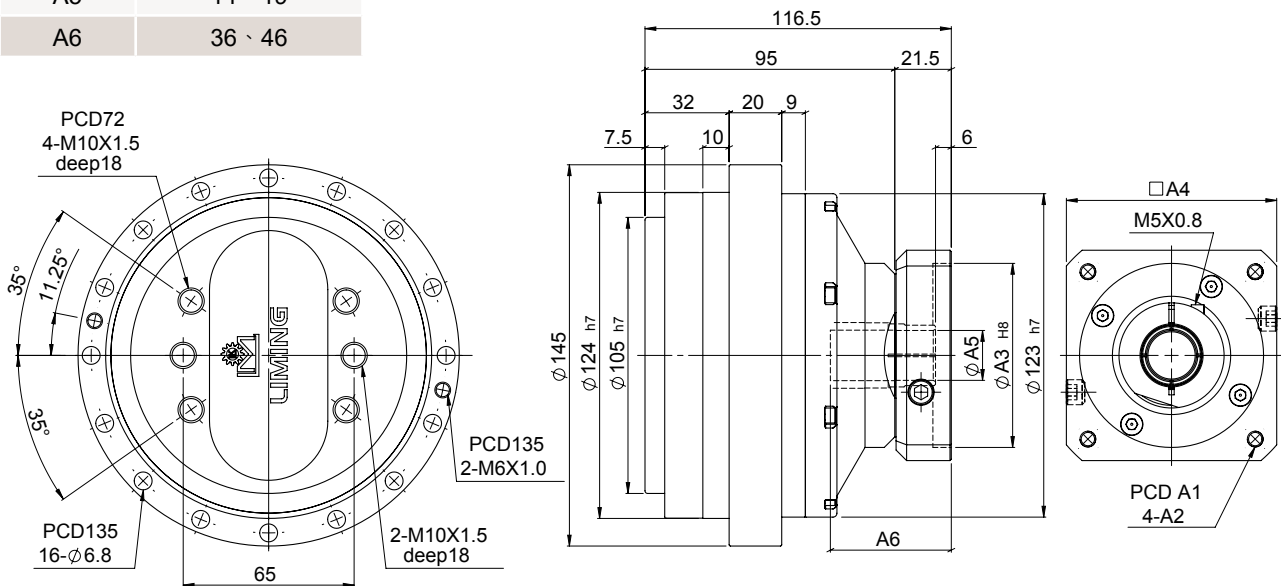

Characteristic		Unit	RSN20
Output Table Supporting Bearing			Angular Contact Ball Bearing
/ Rated Output Torque		Nm	200
/ Max. Output Torque	T_{2NOT}	Nm	5 Time of Rated Output Torque
/ Emergency Stop Torque			
/ Max. Acceleration Torque	T_{2B}	Nm	2.5 Times of Rated Output Torque
/ Inertia Moment		kg.m ²	2 x 10 ⁻⁴
/ Rated Output Speed		rpm	15
/ Max. Output Speed		rpm	50
/ Permissible Input Speed		rpm	3,000
/ Backlash Ps	J_i	arcmin	≤ 1
/ Backlash P0	J_i	arcmin	≤ 3
/ Backlash P1	J_i	arcmin	≤ 5
/ Max. Radial Force	F_{2rB}	N	6,500
/ Max. Axial Force	F_{2aB}	N	4,300
/ Rated Life	L_H	hr	S5 Cycle Operation: >6,000 (S1 Continuous Operation: >3,000 hrs)
/ Torsional Rigidity		Nm/arcmin	70
/ Efficiency	η	%	≥ 85
/ Synthetic Grease		g	170
/ Weight		kg	5.65

MODEL : RSN40

RATIO : 41、61、81、121、161

Unit: mm

Model Code	RSN40
A1	90、100、115、145
A2	M5、M6、M8
A3	70、80、95、110
A4	92、110、130
A5	19、24
A6	49、59

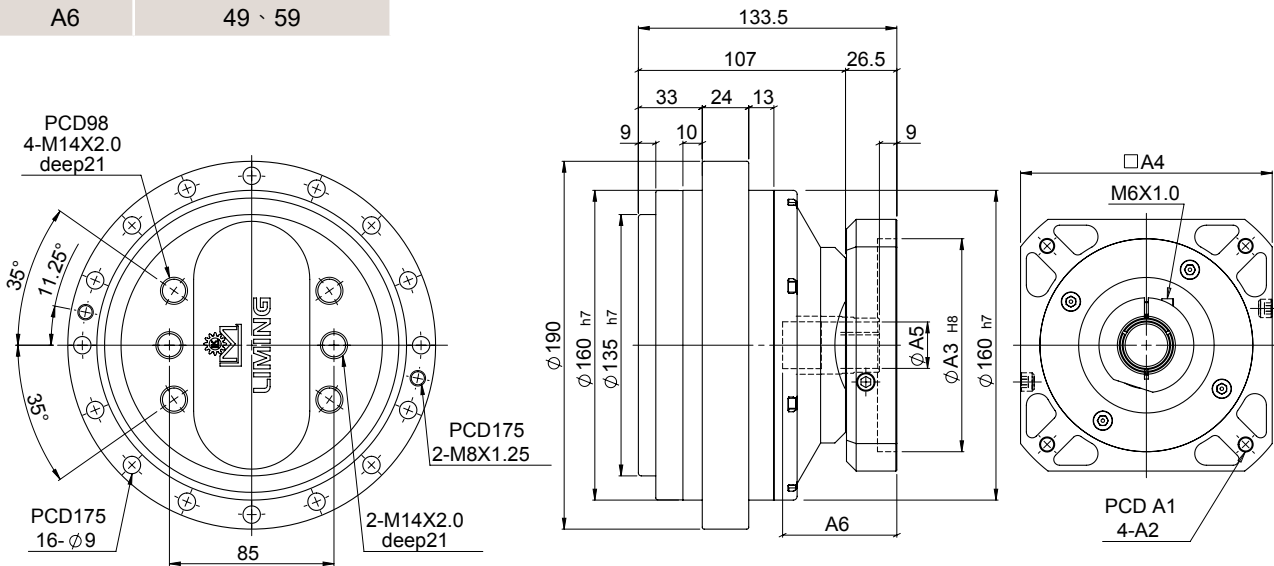

Characteristic		Unit	RSN40
Output Table Supporting Bearing			Angular Contact Ball Bearing
/ Rated Output Torque		Nm	400
/ Max. Output Torque	T_{2NOT}	Nm	5 Time of Rated Output Torque
/ Emergency Stop Torque			
/ Max. Acceleration Torque	T_{2B}	Nm	2.5 Times of Rated Output Torque
/ Inertia Moment		kg.m ²	5×10^{-4}
/ Rated Output Speed		rpm	15
/ Max. Output Speed		rpm	45
/ Permissible Input Speed		rpm	3,000
/ Backlash Ps	J_i	arcmin	≤ 1
/ Backlash P0	J_i	arcmin	≤ 3
/ Backlash P1	J_i	arcmin	≤ 5
/ Max. Radial Force	F_{2rB}	N	8,600
/ Max. Axial Force	F_{2aB}	N	5,700
/ Rated Life	L_H	hr	S5 Cycle Operation: >6,000 (S1 Continuous Operation: >3,000 hrs)
/ Torsional Rigidity		Nm/arcmin	100
/ Efficiency	η	%	≥ 85
/ Synthetic Grease		g	290
/ Weight		kg	10.83

MODEL : RSN80

RATIO : 45、66、81、101、171

Unit: mm

Model Code	RSN80
A1	115、145、165
A2	M6、M8、M10
A3	95、110、130
A4	122、130、150
A5	24、28
A6	27.3、31.3

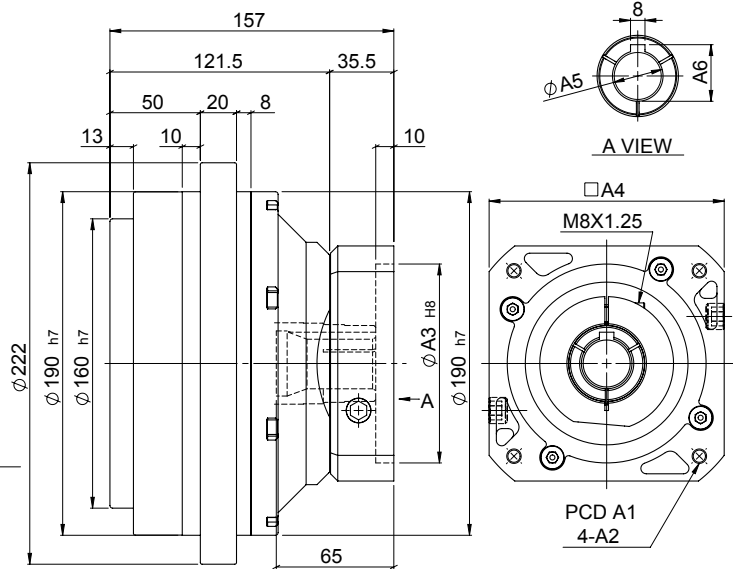
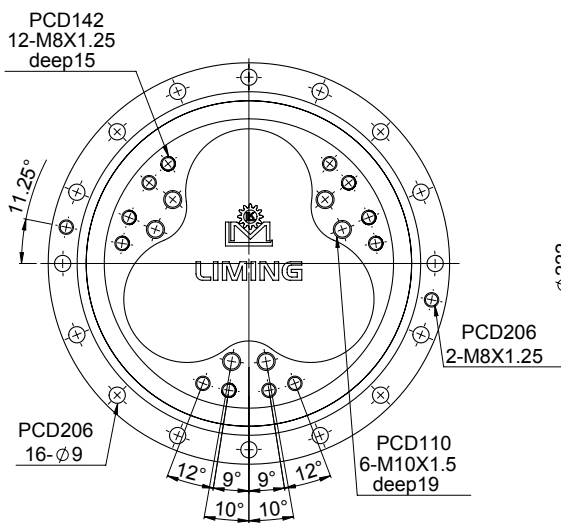
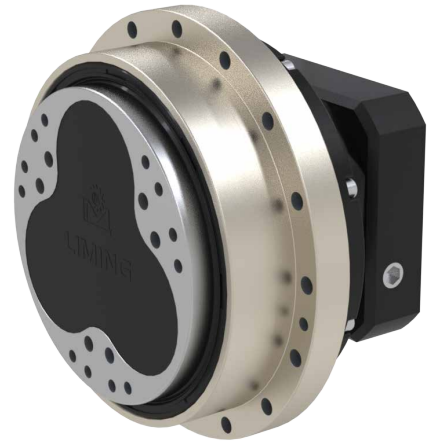

Characteristic		Unit	RSN80
Output Table Supporting Bearing			Angular Contact Ball Bearing
/ Rated Output Torque		Nm	800
/ Max. Output Torque	T_{2NOT}	Nm	5 Time of Rated Output Torque
/ Emergency Stop Torque			
/ Max. Acceleration Torque	T_{2B}	Nm	2.5 Times of Rated Output Torque
/ Inertia Moment		kg.m ²	9×10^{-4}
/ Rated Output Speed		rpm	15
/ Max. Output Speed		rpm	42
/ Permissible Input Speed		rpm	3,000
/ Backlash Ps	J_i	arcmin	≤ 1
/ Backlash P0	J_i	arcmin	≤ 3
/ Backlash P1	J_i	arcmin	≤ 5
/ Max. Radial Force	F_{2rB}	N	12,500
/ Max. Axial Force	F_{2aB}	N	8,200
/ Rated Life	L_H	hr	S5 Cycle Operation: >6,000 (S1 Continuous Operation: >3,000 hrs)
/ Torsional Rigidity		Nm/arcmin	150
/ Efficiency	η	%	≥ 85
/ Synthetic Grease		g	480
/ Weight		kg	17.06

MODEL : RSN110

RATIO : 41、61、81、121、161

Unit: mm

Model Code	RSN110
A1	115、145、165
A2	M6、M8、M10
A3	95、110、130
A4	122、130、150
A5	28、32
A6	8、10
A7	31.3、35.3
A8	72、85

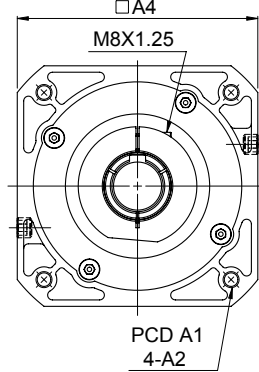
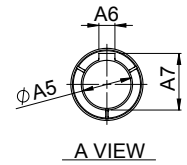
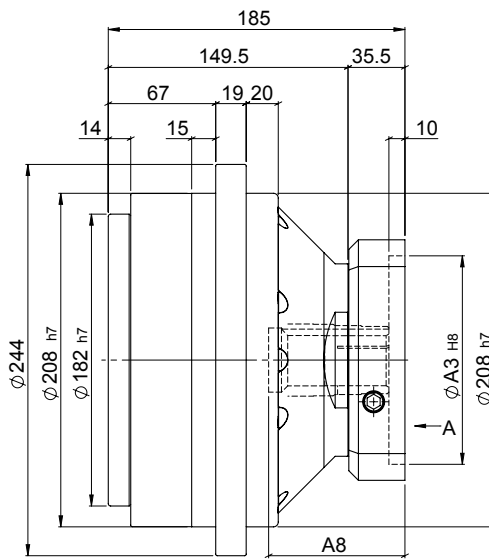
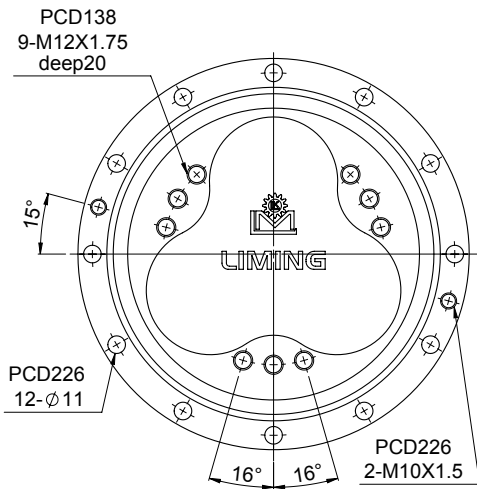
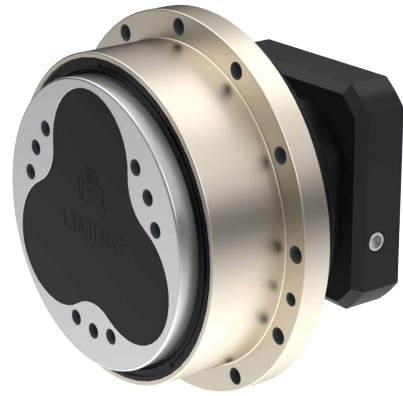

Characteristic		Unit	RSN110
Output Table Supporting Bearing			Angular Contact Ball Bearing
/ Rated Output Torque		Nm	1,100
/ Max. Output Torque	T_{2NOT}	Nm	5 Time of Rated Output Torque
/ Emergency Stop Torque			
/ Max. Acceleration Torque	T_{2B}	Nm	2.5 Times of Rated Output Torque
/ Inertia Moment		kg.m ²	15 x 10 ⁻⁴
/ Rated Output Speed		rpm	15
/ Max. Output Speed		rpm	35
/ Permissible Input Speed		rpm	3,000
/ Backlash Ps	J_i	arcmin	≤ 1
/ Backlash P0	J_i	arcmin	≤ 3
/ Backlash P1	J_i	arcmin	≤ 5
/ Max. Radial Force	F_{2rB}	N	16,000
/ Max. Axial Force	F_{2aB}	N	12,000
/ Rated Life	L_H	hr	S5 Cycle Operation: >6,000 (S1 Continuous Operation: >3,000 hrs)
/ Torsional Rigidity		Nm/arcmin	210
/ Efficiency	η	%	≥ 85
/ Synthetic Grease		g	710
/ Weight		kg	22.45

MODEL : RSN160

RATIO : 41、61、81、121、161

Unit: mm

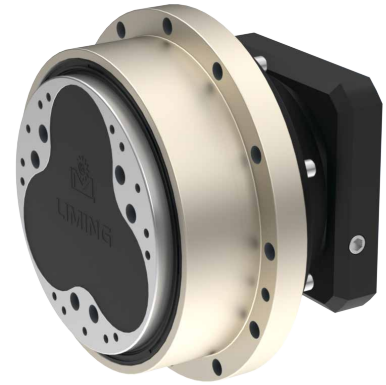

Model Code	RSN160
A1	145、165、200
A2	M8、M10、M12
A3	110、130、180
A4	146、150、190
A5	32、35
A6	35.3、38.3

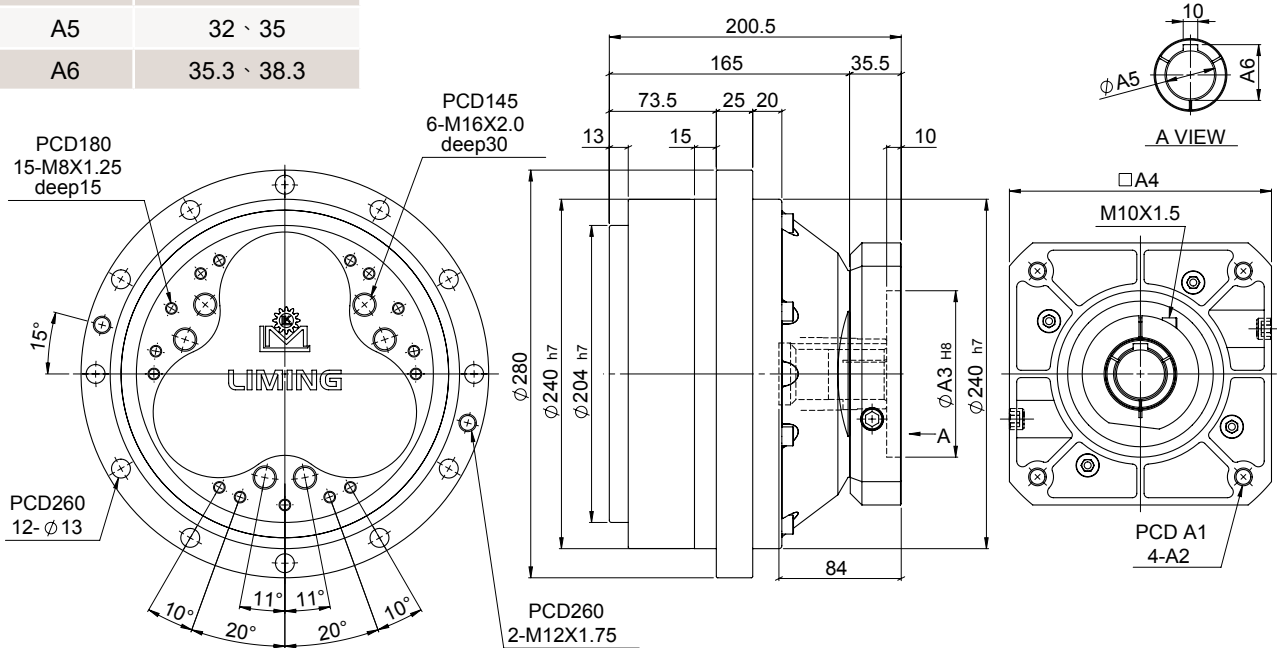

Characteristic		Unit	RSN160
Output Table Supporting Bearing			Angular Contact Ball Bearing
/ Rated Output Torque		Nm	1,600
/ Max. Output Torque	T_{2NOT}	Nm	5 Time of Rated Output Torque
/ Emergency Stop Torque			
/ Max. Acceleration Torque	T_{2B}	Nm	2.5 Times of Rated Output Torque
/ Inertia Moment		kg.m ²	25 x 10 ⁻⁴
/ Rated Output Speed		rpm	15
/ Max. Output Speed		rpm	27
/ Permissible Input Speed		rpm	3,000
/ Backlash Ps	J_t	arcmin	≤ 1
/ Backlash P0	J_t	arcmin	≤ 3
/ Backlash P1	J_t	arcmin	≤ 5
/ Max. Radial Force	F_{2rB}	N	19,000
/ Max. Axial Force	F_{2aB}	N	15,000
/ Rated Life	L_H	hr	S5 Cycle Operation: >6,000 (S1 Continuous Operation: >3,000 hrs)
/ Torsional Rigidity		Nm/arcmin	300
/ Efficiency	η	%	≥ 85
/ Synthetic Grease		g	800
/ Weight		kg	35.25

MODEL : RSN320

RATIO : 41、61、81、121、161

Unit: mm

Model Code	RSN320
A1	165、200、215
A2	M8、M10、M12
A3	114.3、130、180
A4	182、200
A5	35、38
A6	38.3、41.3

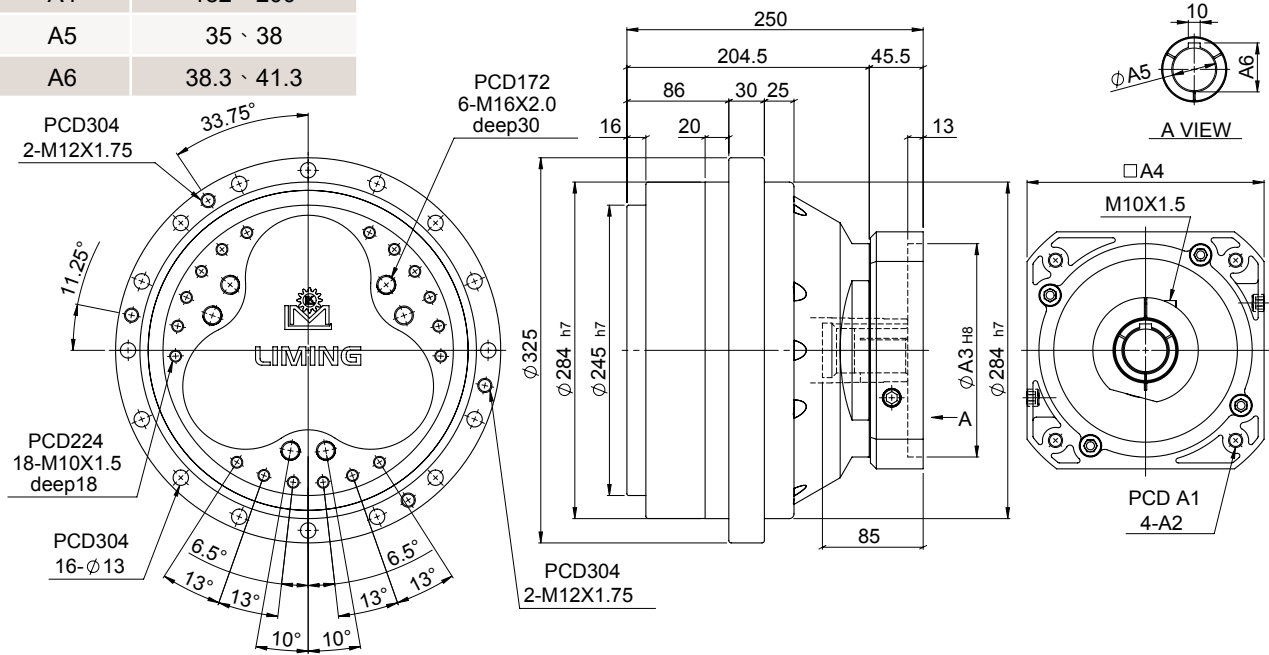
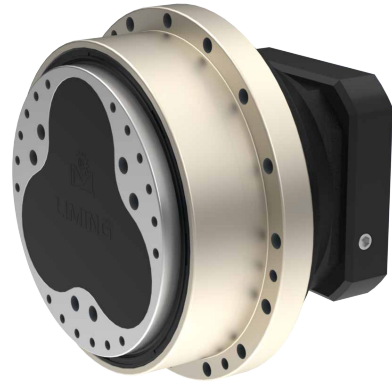

Characteristic		Unit	RSN320
Output Table Supporting Bearing			Angular Contact Ball Bearing
/ Rated Output Torque		Nm	3,200
/ Max. Output Torque	T_{2NOT}	Nm	5 Time of Rated Output Torque
/ Emergency Stop Torque			
/ Max. Acceleration Torque	T_{2B}	Nm	2.5 Times of Rated Output Torque
/ Inertia Moment		kg.m ²	32 x 10 ⁻⁴
/ Rated Output Speed		rpm	15
/ Max. Output Speed		rpm	21
/ Permissible Input Speed		rpm	3,000
/ Backlash Ps	J_t	arcmin	≤ 1
/ Backlash P0	J_t	arcmin	≤ 3
/ Backlash P1	J_t	arcmin	≤ 5
/ Max. Radial Force	F_{2rB}	N	25,300
/ Max. Axial Force	F_{2aB}	N	20,000
/ Rated Life	L_H	hr	S5 Cycle Operation: >6,000 (S1 Continuous Operation: >3,000 hrs)
/ Torsional Rigidity		Nm/arcmin	980
/ Efficiency	η	%	≥ 85
/ Synthetic Grease		g	1,700
/ Weight		kg	55.9