

RCN

MODEL : RCN6

RATIO : 75 · 100 · 125 · 150

Unit: mm

Model Code	RCN6
A1	70 · 75 · 90
A2	M4 · M5 · M6
A3	50 · 60 · 70
A4	64 · 70 · 80

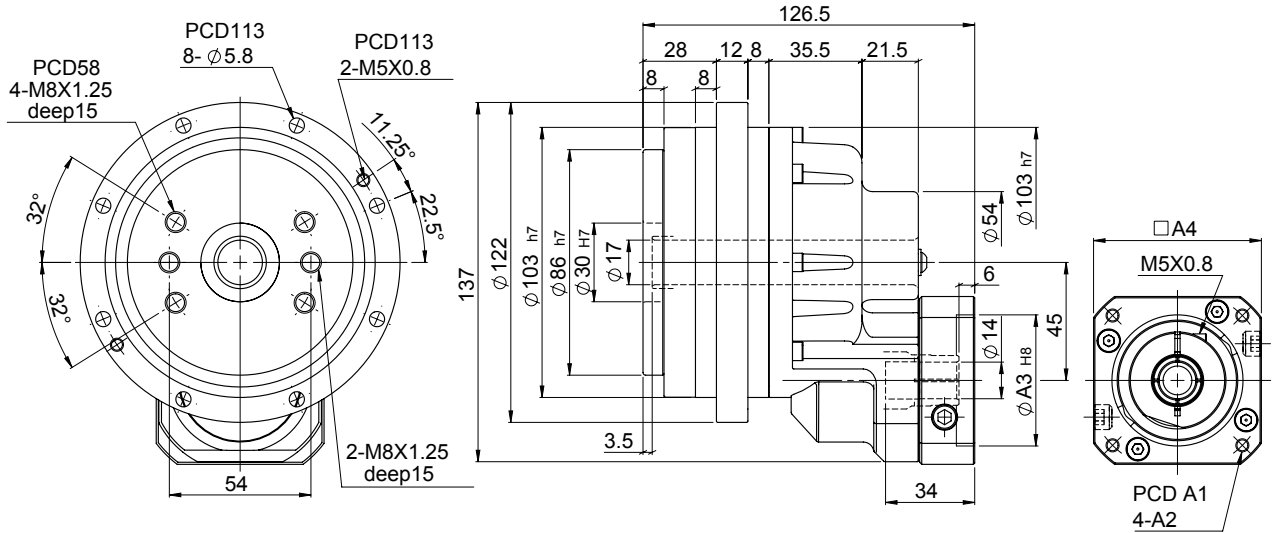

Characteristic		Unit	RCN6
Output Table Supporting Bearing			Angular Contact Ball Bearing
/ Rated Output Torque		Nm	60
/ Max. Output Torque	T_{2NOT}	Nm	5 Time of Rated Output Torque
/ Emergency Stop Torque			
/ Max. Acceleration Torque	T_{2B}	Nm	2 Times of Rated Output Torque
/ Inertia Moment		kg.m ²	1.15 x 10 ⁻⁴
/ Rated Output Speed		rpm	15
/ Max. Output Speed		rpm	55
/ Permissible Input Speed		rpm	3,000
/ Backlash Ps	J_i	arcmin	≤ 2
/ Backlash P0	J_i	arcmin	≤ 4
/ Backlash P1	J_i	arcmin	≤ 6
/ Max. Radial Force	F_{2rB}	N	2,100
/ Max. Axial Force	F_{2aB}	N	1,500
/ Rated Life	L_H	hr	S5 Cycle Operation: >6,000 (S1 Continuous Operation: >3,000 hrs)
/ Torsional Rigidity		Nm/arcmin	50
/ Efficiency	η	%	≥ 85
/ Synthetic Grease		g	100
/ Weight		kg	3.6

MODEL : RCN20

RATIO : 69、115、138

Unit: mm

Model Code	RCN20
A1	70、75、90
A2	M4、M5、M6
A3	50、60、70
A4	64、70、80
A5	※ 14、19
A6	33.5、41.5

※ Ø14 : 1/69、1/115、1/138
 ※ Ø19 : 1/69、1/115

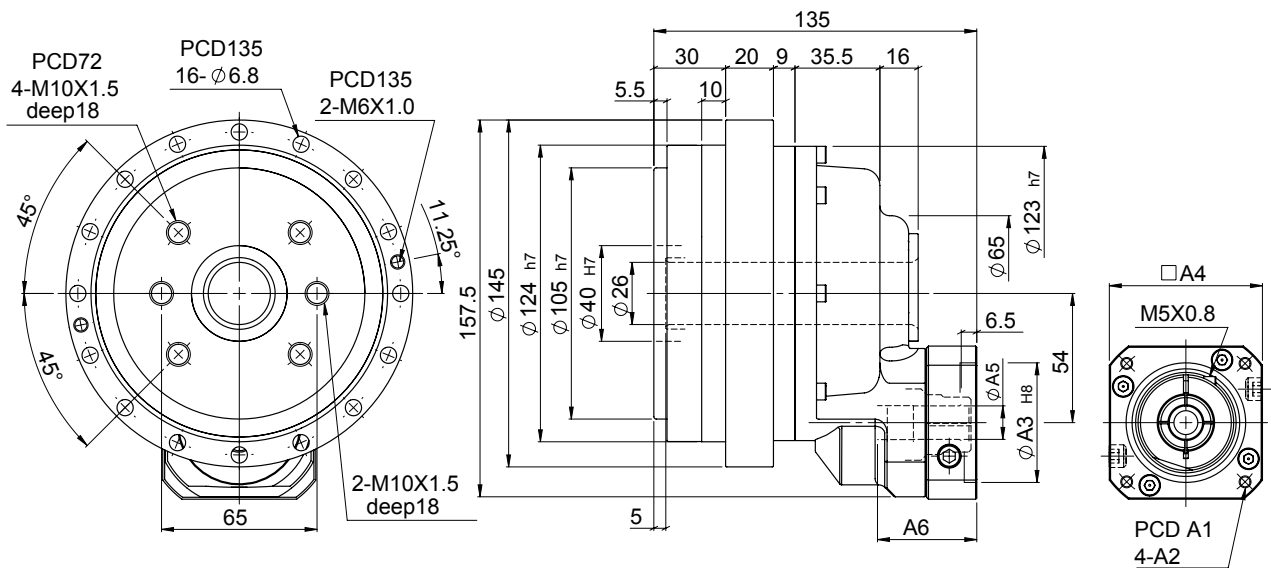
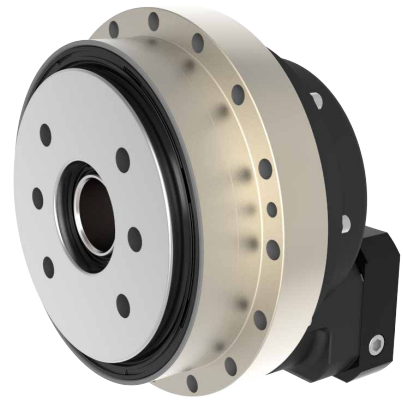

Characteristic		Unit	RCN20
Output Table Supporting Bearing			Angular Contact Ball Bearing
/ Rated Output Torque		Nm	200
/ Max. Output Torque	T_{2NOT}	Nm	5 Time of Rated Output Torque
/ Emergency Stop Torque			
/ Max. Acceleration Torque	T_{2B}	Nm	2.5 Times of Rated Output Torque
/ Inertia Moment		kg.m ²	2 x 10 ⁻⁴
/ Rated Output Speed		rpm	15
/ Max. Output Speed		rpm	50
/ Permissible Input Speed		rpm	3,000
/ Backlash Ps	J_i	arcmin	≤ 1
/ Backlash P0	J_i	arcmin	≤ 3
/ Backlash P1	J_i	arcmin	≤ 5
/ Max. Radial Force	F_{2rB}	N	6,500
/ Max. Axial Force	F_{2aB}	N	4,300
/ Rated Life	L_H	hr	S5 Cycle Operation: >6,000 (S1 Continuous Operation: >3,000 hrs)
/ Torsional Rigidity		Nm/arcmin	70
/ Efficiency	η	%	≥ 85
/ Synthetic Grease		g	170
/ Weight		kg	6.45

MODEL : RCN40

RATIO : 87、116、145

Unit: mm

Model Code	RCN40
A1	90、100、115、145
A2	M5、M6、M8
A3	70、80、95、110
A4	92、110、130
A5	※19、22
A6	44、58

※ Ø19 : 1/87、1/116、1/145
 Ø22 : 1/87、1/116

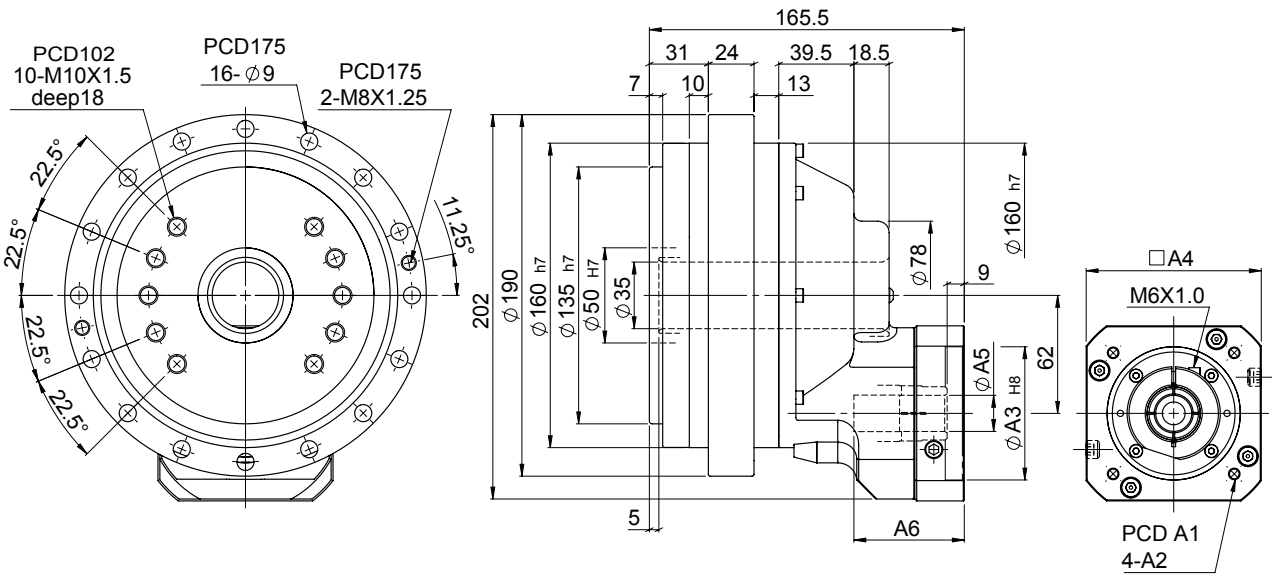

Characteristic		Unit	RCN40
Output Table Supporting Bearing			Angular Contact Ball Bearing
/ Rated Output Torque		Nm	400
/ Max. Output Torque	T_{2NOT}	Nm	5 Time of Rated Output Torque
/ Emergency Stop Torque			
/ Max. Acceleration Torque	T_{2B}	Nm	2.5 Times of Rated Output Torque
/ Inertia Moment		kg.m ²	5 x 10 ⁻⁴
/ Rated Output Speed		rpm	15
/ Max. Output Speed		rpm	45
/ Permissible Input Speed		rpm	3,000
/ Backlash Ps	J_i	arcmin	≤ 1
/ Backlash P0	J_i	arcmin	≤ 3
/ Backlash P1	J_i	arcmin	≤ 5
/ Max. Radial Force	F_{2rB}	N	8,600
/ Max. Axial Force	F_{2aB}	N	5,700
/ Rated Life	L_H	hr	S5 Cycle Operation: >6,000 (S1 Continuous Operation: >3,000 hrs)
/ Torsional Rigidity		Nm/arcmin	100
/ Efficiency	η	%	≥ 85
/ Synthetic Grease		g	290
/ Weight		kg	11.4

MODEL : RCN80

RATIO : 78 、 104 、 130

Unit: mm

Model Code	RCN80
A1	90 、 100 、 115 、 145
A2	M5 、 M6 、 M8
A3	70 、 80 、 95 、 110
A4	92 、 110 、 130
A5	22 、 24

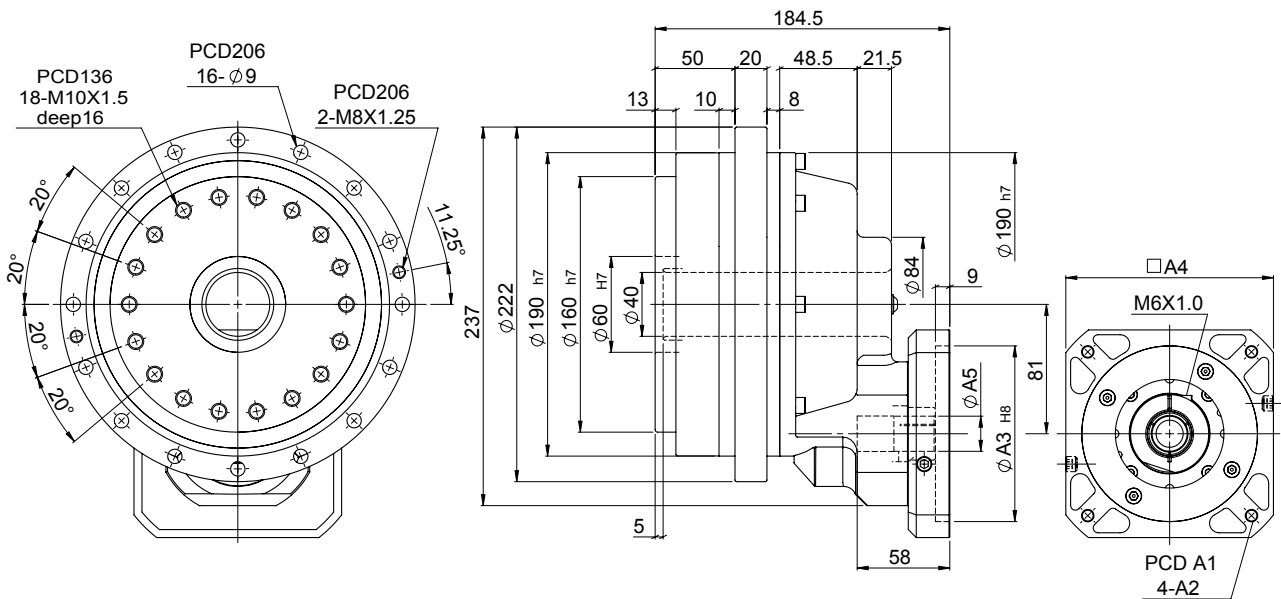
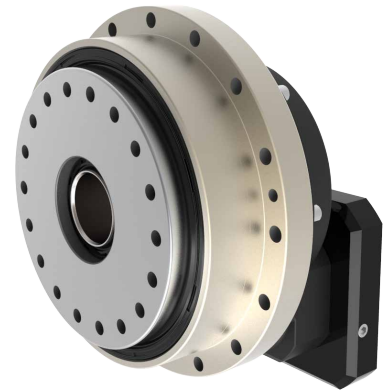

Characteristic		Unit	RCN80
Output Table Supporting Bearing			Angular Contact Ball Bearing
/ Rated Output Torque		Nm	800
/ Max. Output Torque	T_{2NOT}	Nm	5 Time of Rated Output Torque
/ Emergency Stop Torque			
/ Max. Acceleration Torque	T_{2B}	Nm	2.5 Times of Rated Output Torque
/ Inertia Moment		kg.m ²	9×10^{-4}
/ Rated Output Speed		rpm	15
/ Max. Output Speed		rpm	42
/ Permissible Input Speed		rpm	3,000
/ Backlash Ps	J_t	arcmin	≤ 1
/ Backlash P0	J_t	arcmin	≤ 3
/ Backlash P1	J_t	arcmin	≤ 5
/ Max. Radial Force	F_{2rB}	N	12,500
/ Max. Axial Force	F_{2aB}	N	8,200
/ Rated Life	L_H	hr	S5 Cycle Operation: >6,000 (S1 Continuous Operation: >3,000 hrs)
/ Torsional Rigidity		Nm/arcmin	150
/ Efficiency	η	%	≥ 85
/ Synthetic Grease		g	480
/ Weight		kg	18.86

MODEL : RCN110

RATIO : 66 、 99 、 132

Unit: mm

Model Code	RCN110
A1	115 、 145 、 165
A2	M6 、 M8 、 M10
A3	95 、 110 、 130
A4	122 、 130 、 150
A5	24 、 28
A6	27.3 、 31.3

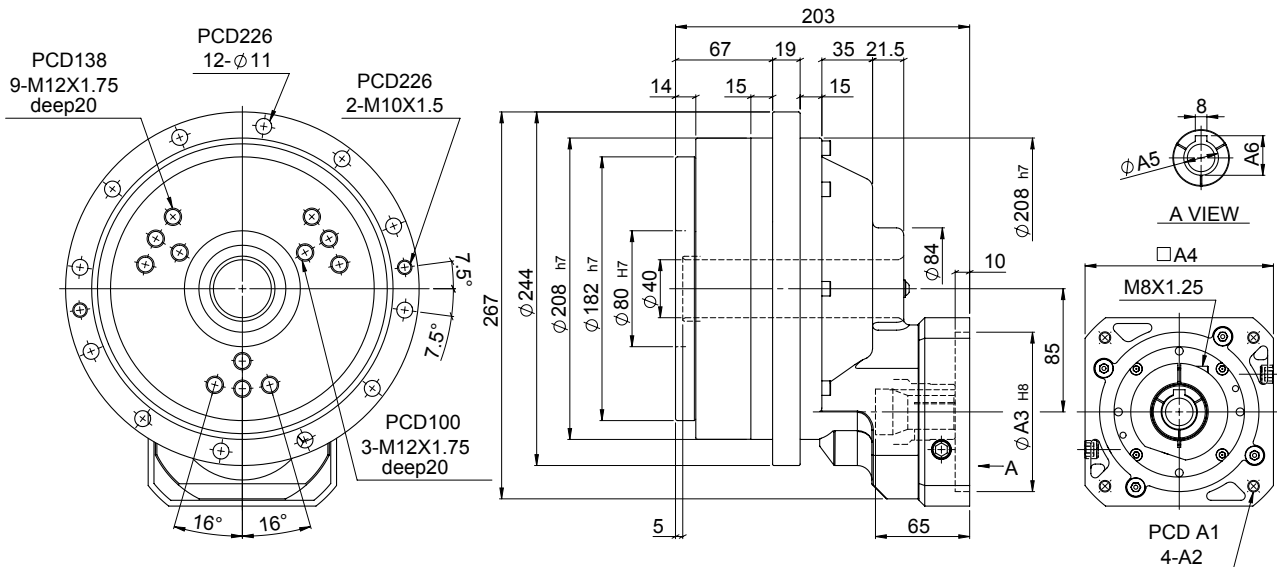

Characteristic		Unit	RCN110
Output Table Supporting Bearing			Angular Contact Ball Bearing
/ Rated Output Torque		Nm	1,100
/ Max. Output Torque	T_{2NOT}	Nm	5 Time of Rated Output Torque
/ Emergency Stop Torque			
/ Max. Acceleration Torque	T_{2B}	Nm	2.5 Times of Rated Output Torque
/ Inertia Moment		kg.m ²	15 x 10 ⁻⁴
/ Rated Output Speed		rpm	15
/ Max. Output Speed		rpm	35
/ Permissible Input Speed		rpm	3,000
/ Backlash Ps	J_t	arcmin	≤ 1
/ Backlash P0	J_t	arcmin	≤ 3
/ Backlash P1	J_t	arcmin	≤ 5
/ Max. Radial Force	F_{2rB}	N	16,000
/ Max. Axial Force	F_{2aB}	N	12,000
/ Rated Life	L_H	hr	S5 Cycle Operation: >6,000 (S1 Continuous Operation: >3,000 hrs)
/ Torsional Rigidity		Nm/arcmin	210
/ Efficiency	η	%	≥ 85
/ Synthetic Grease		g	710
/ Weight		kg	27.1

MODEL : RCN160

RATIO : 66 、 99 、 132

Unit: mm

Model Code	RCN160
A1	115 、 145 、 165
A2	M6 、 M8 、 M10
A3	95 、 110 、 130
A4	122 、 130 、 150
A5	28 、 32
A6	8 、 10
A7	31.3 、 35.3

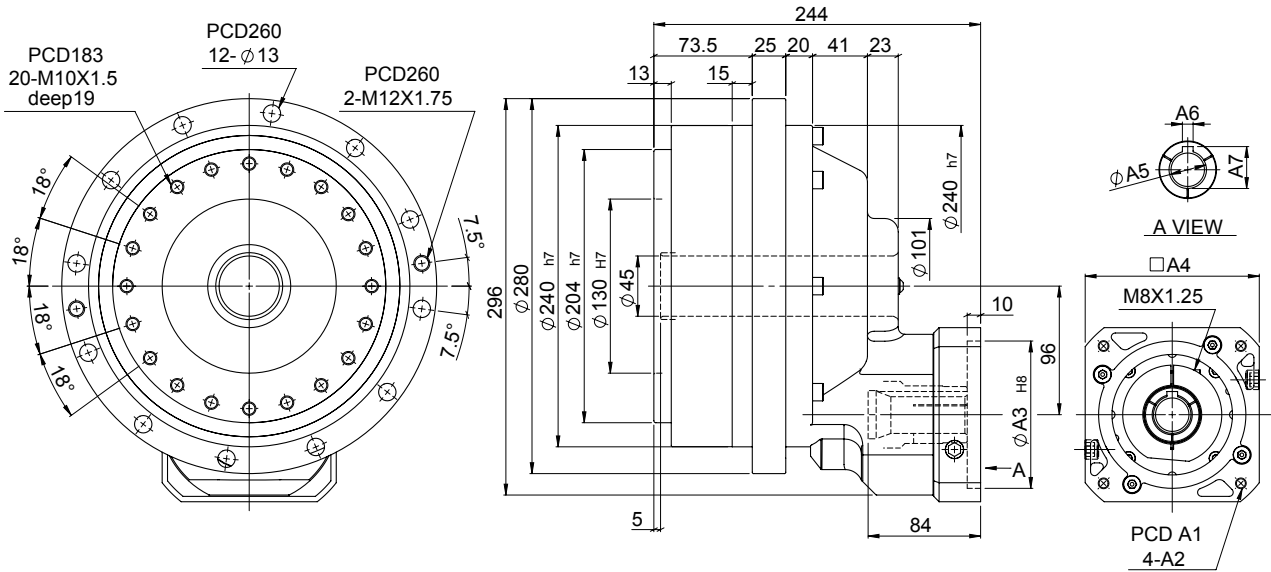
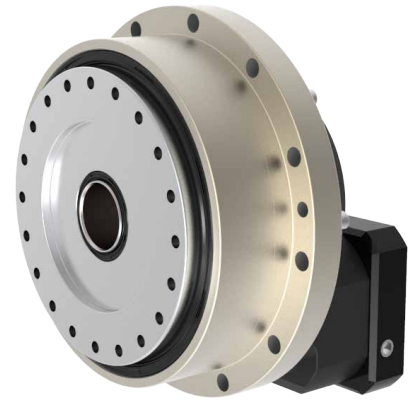

Characteristic		Unit	RCN160
Output Table Supporting Bearing			Angular Contact Ball Bearing
/ Rated Output Torque		Nm	1,600
/ Max. Output Torque	T_{2NOT}	Nm	5 Time of Rated Output Torque
/ Emergency Stop Torque			
/ Max. Acceleration Torque	T_{2B}	Nm	2.5 Times of Rated Output Torque
/ Inertia Moment		kg.m ²	25 x 10 ⁻⁴
/ Rated Output Speed		rpm	15
/ Max. Output Speed		rpm	27
/ Permissible Input Speed		rpm	3,000
/ Backlash Ps	J_t	arcmin	≤ 1
/ Backlash P0	J_t	arcmin	≤ 3
/ Backlash P1	J_t	arcmin	≤ 5
/ Max. Radial Force	F_{2rB}	N	19,000
/ Max. Axial Force	F_{2aB}	N	15,000
/ Rated Life	L_H	hr	S5 Cycle Operation: >6,000 (S1 Continuous Operation: >3,000 hrs)
/ Torsional Rigidity		Nm/arcmin	300
/ Efficiency	η	%	≥ 85
/ Synthetic Grease		g	800
/ Weight		kg	36.9

MODEL : RCN320

RATIO : 82、123、164

Unit: mm

Model Code	RCN320
A1	145、165、200
A2	M8、M10、M12
A3	110、130、180
A4	146、150、190
A5	32、35
A6	35.3、38.3

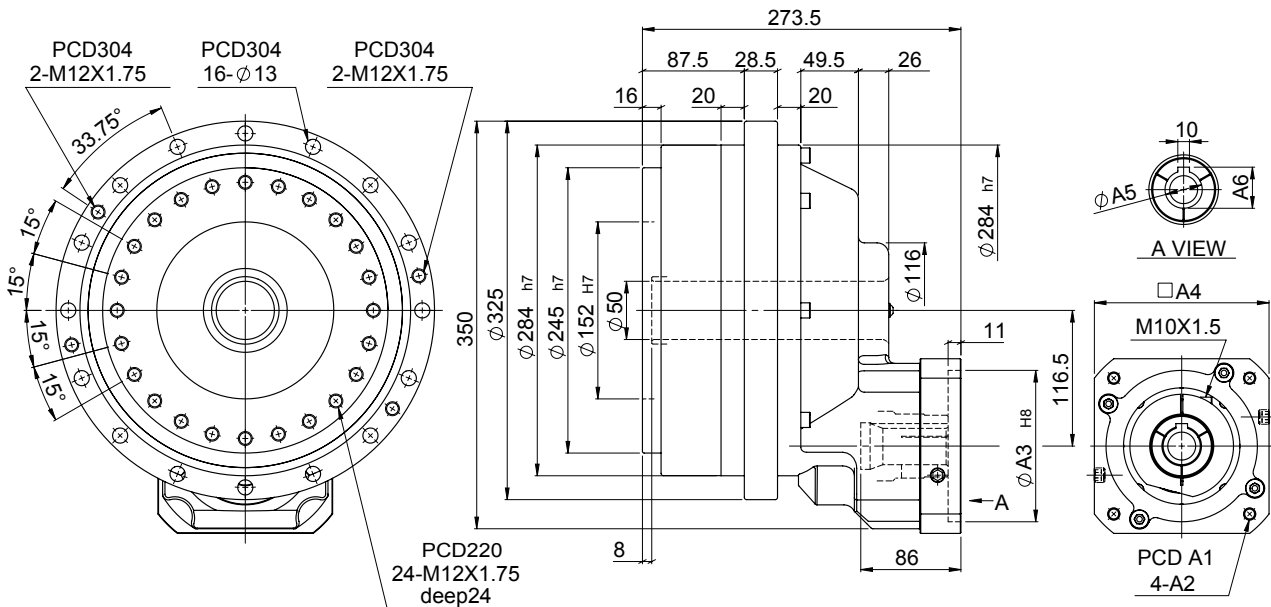

Characteristic		Unit	RCN320
Output Table Supporting Bearing			Angular Contact Ball Bearing
/ Rated Output Torque		Nm	3,200
/ Max. Output Torque	T_{2NOT}	Nm	5 Time of Rated Output Torque
/ Emergency Stop Torque			
/ Max. Acceleration Torque	T_{2B}	Nm	2.5 Times of Rated Output Torque
/ Inertia Moment		kg.m ²	32 x 10 ⁻⁴
/ Rated Output Speed		rpm	15
/ Max. Output Speed		rpm	21
/ Permissible Input Speed		rpm	3,000
/ Backlash Ps	J_t	arcmin	≤ 1
/ Backlash P0	J_t	arcmin	≤ 3
/ Backlash P1	J_t	arcmin	≤ 5
/ Max. Radial Force	F_{2rB}	N	25,300
/ Max. Axial Force	F_{2aB}	N	20,000
/ Rated Life	L_H	hr	S5 Cycle Operation: >6,000 (S1 Continuous Operation: >3,000 hrs)
/ Torsional Rigidity		Nm/arcmin	980
/ Efficiency	η	%	≥ 85
/ Synthetic Grease		g	1,700
/ Weight		kg	63.9