

# ST series

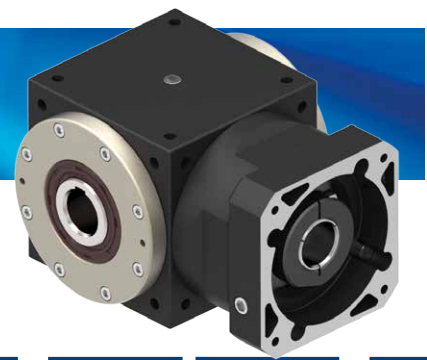













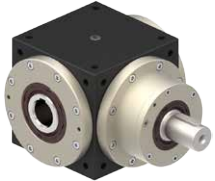
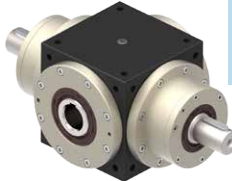



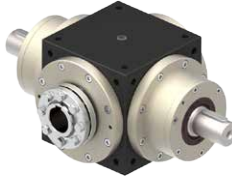



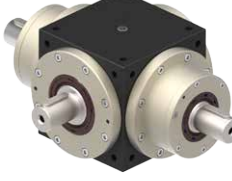

## Indication of Model Numbers

ST	90	F	N	B	5	L	P0
Type	Model	Input	Output	Bearing	Ratio	Shaft Direction	Backlash Class
ST	65 75 90 110 140 170 210 240	F: Input Flange R44: Reducer 1-Stage: R44、R62... 2-Stage: R62S... 2-Stage (A-Type): R44A、R62A... D: Single Input Shaft (Keyway) D1: Single Input Shaft (No Keyway) Y: Double Input Shaft (Keyway) Y1: Double Input Shaft (No Keyway)	O: Hollow Output Shaft N: Single Clamping (Keyway) N1: Single Clamping (No Keyway) M: Double Clamping S: Single Output Shaft (Keyway) S1: Single Output Shaft (No Keyway) V: Double Output Shaft (Keyway) V1: Double Output Shaft (No Keyway) P: Ball Screw (75#~210#)  Taper Bearing Only	B: Ball Bearing (65#~240#) (Ratio: 1~5)  T: Taper Bearing (75#~240#) (Ratio: 2~5)	1-Stage 1, 2, 3, 4, 5  -----  With 1-Stage Planetary Reducer 10 ~ 50  With 2-Stage Planetary Reducer 75 ~ 500	L: Left Shaft R: Right Shaft  ----- 1.  Shaft direction is optional for output type N, S. 2.  Output type P only for R shaft.	P0 P1 P2

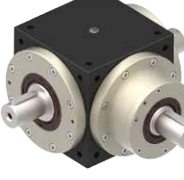
### The Model & Ratio Table of Bevel Gear Reducer Assembly Planetary Reducer

Model	Ratio	Flange Model	Planetary Reducer Model	Ratio of 1-Stage Planetary Reducer	Ratio of 2-Stage Planetary Reducer
				5 ~ 10	25 ~ 50 ~ 100
65	1 2 3 4 5	62	44	Ratio of Bevel Gear Reducer Fitted with 1-Stage Planetary Reducer  10、15、20、25、30、40、50	Ratio of Bevel Gear Reducer Fitted with 1-Stage Planetary Reducer  75、100、125、150、200、250、300、400、500
75		62	44		
90		90	62		
110		90	80		
140		120	90		
170		142	120		
210		180	142		
240		220	180		

# Selection of Type

		Input Type			
		Input Flange	R Reducer	D Single Input Shaft	Y Double Input Shaft
Output Type	O Hollow Output Shaft				
		FO	RO	DO	YO
	N Single Clamping				
		FN	RN	DN	YN
	M Double Clamping				
		FM	RM	DM	YM
	S Single Output Shaft				
	FS	RS	DS	YS	
V Double Output Shaft					
	FV	RV	DV	YV	
P Ball Screw					
	FP	RP	DP	YP	

- Shaft direction is optional for output type N, S.
- Output type P only for R shaft.

# Rotating Direction

ST

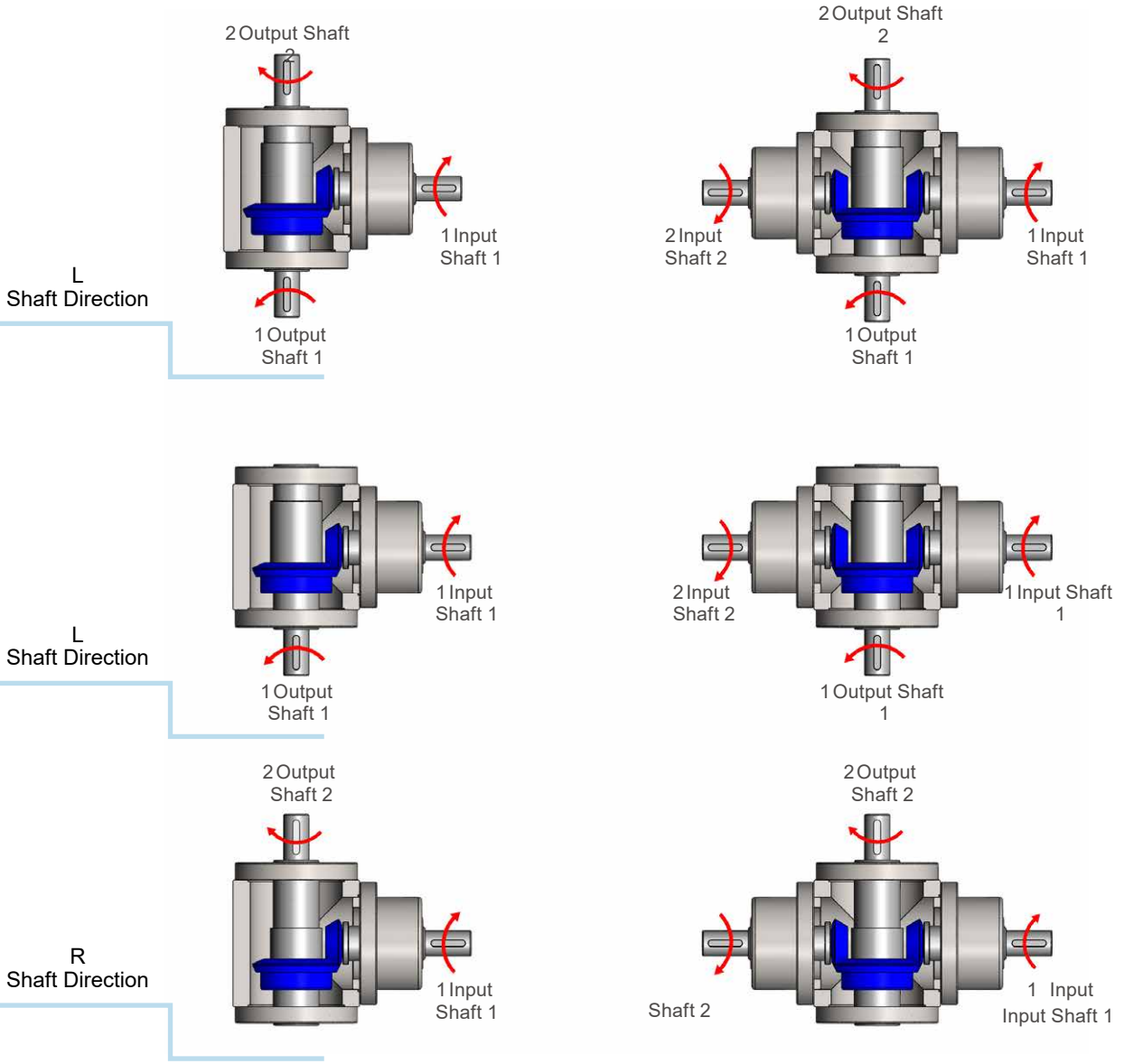
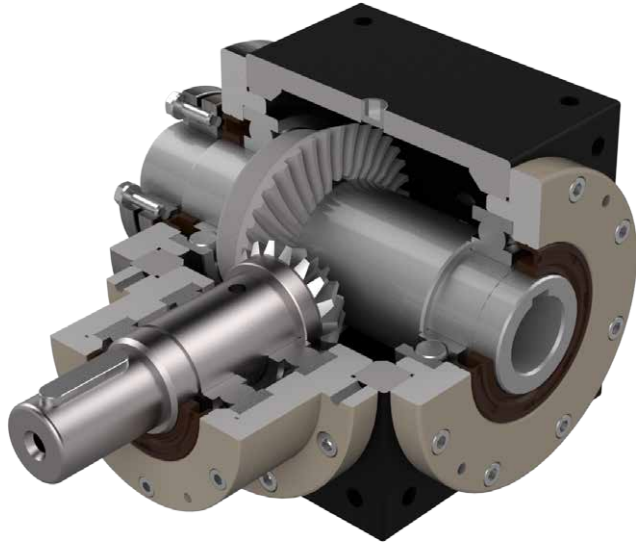

Note:

Standard product is L shaft direction, R shaft direction is optional.

# Selection Direction of Installation

ST

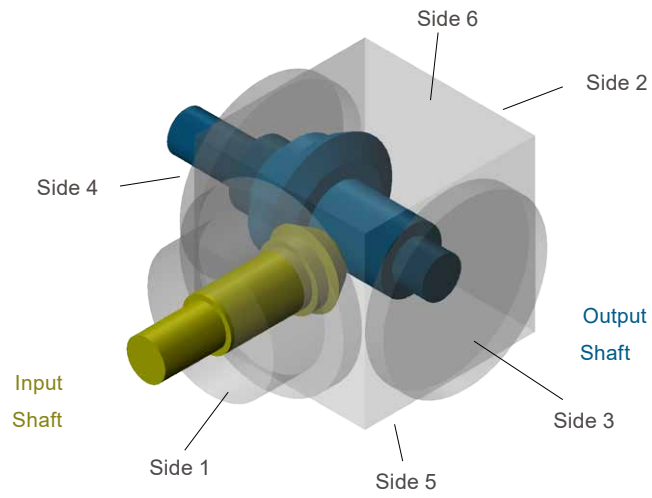

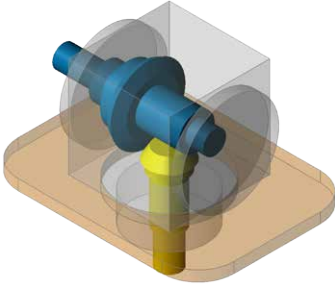
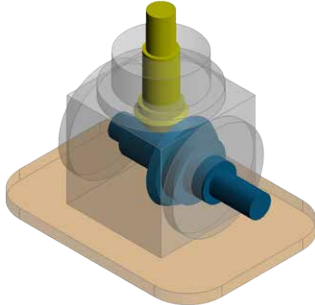
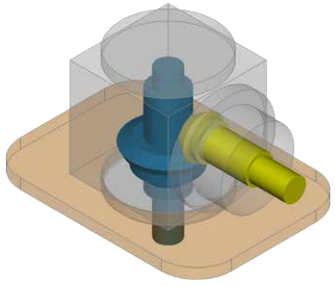
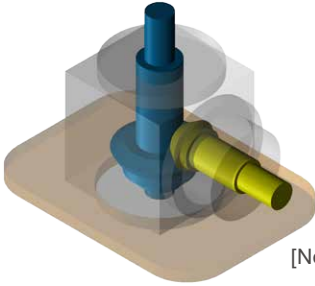
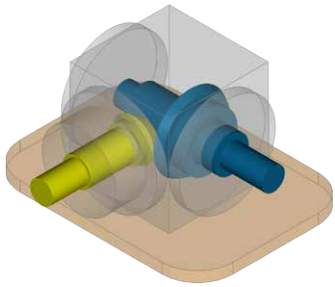
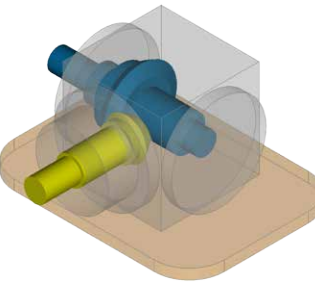
	
Side 1	Side 2
	
Side 3	Side 4 [Note 1]
	
Side 5	Side 6

[ Note 1 ] • Output type for R shaft.

# Features of ST Series

ST

ST

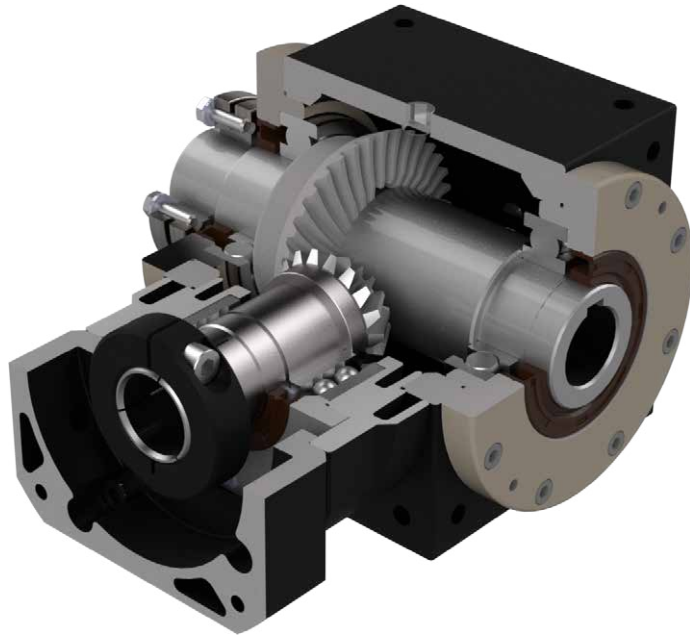

## High precision grinded and carburized spiral bevel gears

- High precision grinded and carburized spiral bevel gears to meet standard AGMA12.

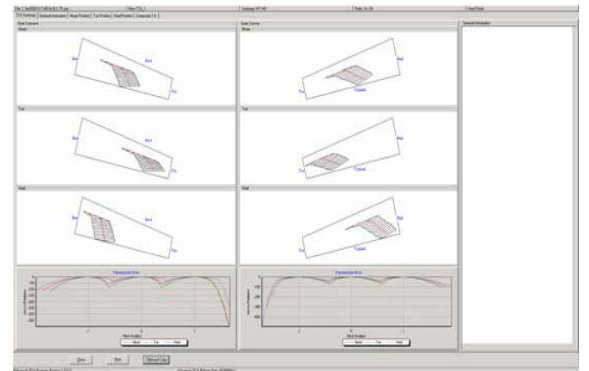
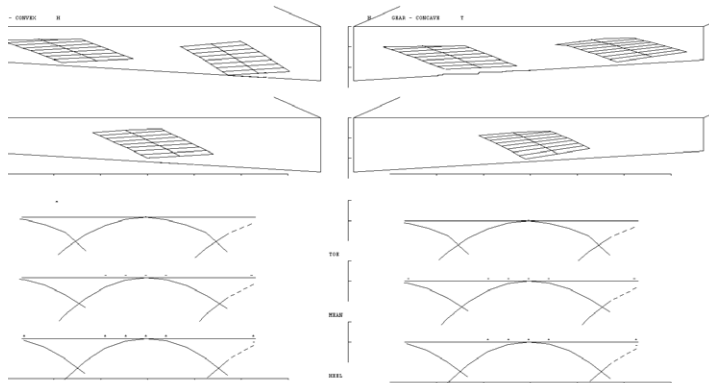

## Optimized Design and CAE Analysis

- Use Gleason's design software to design new spiral bevel gears. Through the ideal gear contact pattern for application, achieve high permissible output torque.
- Employs 3D-CAE software for analysis and design, the software allows for analyzing the strength of the entire gear reducer and helical teeth. Increasing the service life of gears and the gear reducer.

# Features of ST Series

## ST

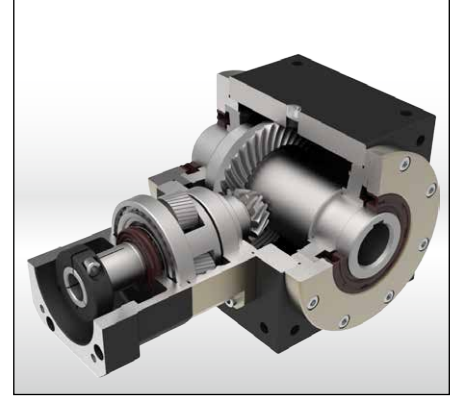
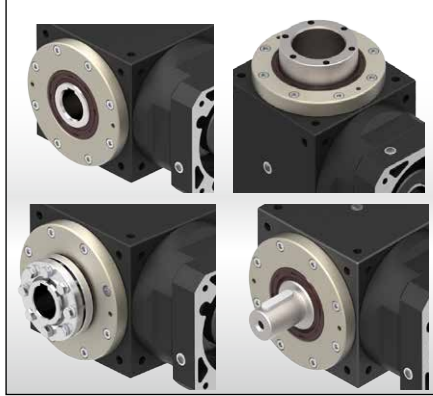

### Low Backlash

- Using Gleason high precision CNC grinding machine to grinding the spiral bevel gears.
- Torsional backlash depending on design up to <math><2\text{ arcmin}</math>.

### Mounting Position

- Multiple precision machined surface is easy for assembly, suitable for any optional mounting orientation.
- Output shaft and input shaft are designed to suit for various industries applications.

### More High Gear Ratio

- High precision grinded and carburized spiral bevel gears with optimal designed planetary gear can do ratio 500: 1.

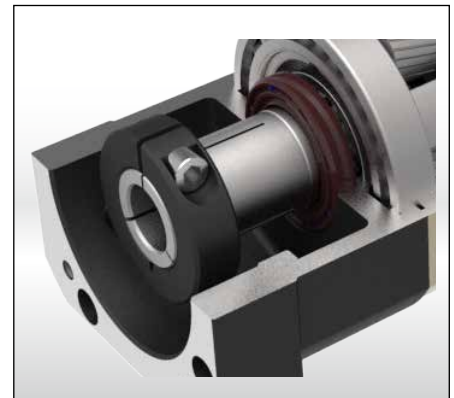
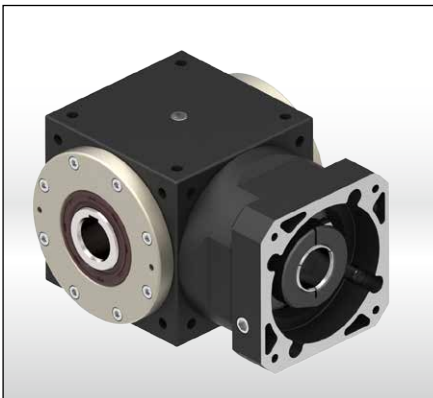

### No Maintenance

- It features no maintenance and long service life.

### High Output Torque

- The gear box is one-piece constructed to ensure the high rigidity and corrosion-resistant capability.

### Collet Locking Mechanism

- The input-end and the motor are coupled through a collet locking mechanism. It has passed dynamical balance analysis to assure concentricity and balance on the connection and no backlash for power transmission while running at high speed.

# Characteristic of ST Series

## ST

### 1-Stage

Model No.		Unit	Ratio	65	75	90	110	140	170	210	240
/ Rated Output Torque (Nominal output torque)	$T_{2N}$	Nm	1	25	45	78	150	360	585	1,300	1,688
			2	24	42	68	150	330	544	1,220	1,510
			3	18	33	54	120	270	450	1,020	1,266
			4	13	28	52	100	224	376	860	1,048
			5	12	25	40	85	196	320	740	1,022
/ Max. Acceleration Torque	$T_{2B}$	Nm	1~5	1.5 Times of Rated Output Torque							
/ Max. Output Torque / Emergency Stop Torque	$T_{2NOT}$	Nm	1~5	3 Times of Rated Output Torque							
/ Rated Input Speed	$n_{1N}$	rpm	1~5	3,000	3,000	3,000	2,500	2,500	2,000	2,000	2,000
/ Max. Input Speed	$n_{1B}$	rpm	1~5	6,000	6,000	5,500	4,500	3,500	3,000	3,000	3,000
/ Backlash		arcmin	P0	-	≤ 3	≤ 3	≤ 3	≤ 3	≤ 3	≤ 3	≤ 3
			P1	≤ 6	≤ 6	≤ 6	≤ 6	≤ 6	≤ 6	≤ 6	≤ 6
			P2	≤ 9	≤ 9	≤ 9	≤ 9	≤ 9	≤ 9	≤ 9	≤ 9
/ Max. Radial Force Ball Bearing	$F_{2rB}$	N	1~5	700	1,050	1,500	2,360	3,080	4,800	6,400	9,500
/ Max. Axial Force Ball Bearing	$F_{2aB}$	N	1~5	350	525	750	1,180	1,540	2,400	3,200	4,800
/ Max. Radial Force Taper Bearing	$F_{2rB}$	N	2~5	-	2,400	3,200	5,000	6,500	9,100	13,000	17,000
/ Max. Axial Force Taper Bearing	$F_{2aB}$	N	2~5	-	1,200	1,600	2,500	3,250	4,550	6,500	8,500
/ Service Life	$L_H$	hr	1~5	65#~210# : S5 Cycle Operation: >30,000 (S1 Continuous Operation: >15,000 hrs) 240# : S S5 Cycle Operation: >20,000 (S1 Continuous Operation: >10,000 hrs)							
/ Efficiency	$\eta$	%	1~5	94% ~ 98%							
/ Operating Temperature		°C	1~5	-30°C ~ +100°C							
/ Lubrication			1~5	Synthetic Oil							
/ Noise Level		dB	1~5	≤ 65	≤ 67	≤ 71	≤ 73	≤ 74	≤ 75	≤ 77	≤ 80

### Mass Moments of Inertia (kgcm<sup>2</sup>)

Ratio	65	75	90	110	140	170	210	240
1	0.51	1.79	4.93	12.5	36.8	85.9	287	428.4
2	0.44	0.95	2.78	7.41	15.6	39.3	123	250.8
3	0.43	0.78	2.34	6.18	10.9	28.5	84.1	183.5
4	0.43	0.72	2.18	5.71	9.19	24.5	69.9	157.4
5	0.43	0.69	2.10	5.48	8.32	22.6	62.7	137.4

# Characteristic of ST Series

## ST

### 2-Stage

Model No.		Unit	Ratio	65	75	90	110	140	170	210	240
/ Rated Output Torque (Nominal output torque)	$T_{2N}$	Nm	10	24	42	68	150	330	544	1,220	1,510
			15	18	33	54	120	270	450	1,020	1,266
			20	13	28	48	100	224	376	860	1,048
			25	12	25	40	85	196	320	740	1,022
			30	18	33	54	120	270	450	1,020	1,266
			40	13	28	52	100	224	376	860	1,048
			50	12	25	40	85	196	320	740	1,022
/ Max. Acceleration Torque	$T_{2B}$	Nm	10~50	1.5 Times of Rated Output Torque							
/ Max. Output Torque / Emergency Stop Torque	$T_{2NOT}$	Nm	10~50	3 Times of Rated Output Torque							
/ Rated Input Speed	$n_{1N}$	rpm	10~50	3,000	3,000	3,000	3,000	3,000	3,000	3,000	2,500
/ Max. Input Speed	$n_{1B}$	rpm	10~50	6,000	6,000	6,000	6,000	6,000	5,000	5,000	4,000
/ Backlash		arcmin	P0	-	≤ 4	≤ 4	≤ 4	≤ 4	≤ 4	≤ 4	≤ 4
			P1	≤ 7	≤ 7	≤ 7	≤ 7	≤ 7	≤ 7	≤ 7	≤ 7
			P2	≤ 10	≤ 10	≤ 10	≤ 10	≤ 10	≤ 10	≤ 10	≤ 10
/ Max. Radial Force Ball Bearing	$F_{2rB}$	N	10~50	700	1,050	1,500	2,360	3,080	4,800	6,400	9,500
/ Max. Axial Force Ball Bearing	$F_{2aB}$	N	10~50	350	525	750	1,180	1,540	2,400	3,200	4,800
/ Max. Radial Force Taper Bearing	$F_{2rB}$	N	10~50	-	2,400	3,200	5,000	6,500	9,100	13,000	17,000
/ Max. Axial Force Taper Bearing	$F_{2aB}$	N	10~50	-	1,200	1,600	2,500	3,250	4,550	6,500	8,500
/ Service Life	$L_H$	hr	10~50	65#~210# : S5 Cycle Operation: >30,000 (S1 Continuous Operation: >15,000 hrs) 240# : S5 Cycle Operation: >20,000 (S1 Continuous Operation: >10,000 hrs)							
/ Efficiency	$\eta$	%	10~50	90% ~ 94%							
/ Operating Temperature		°C	10~50	-30°C ~ +100°C							
/ Lubrication			10~50	Synthetic Oil							
/ Noise Level		dB	10~50	≤ 68	≤ 69	≤ 73	≤ 74	≤ 75	≤ 76	≤ 78	≤ 82

### Mass Moments of Inertia (kgcm<sup>2</sup>)

Ratio	65	75	90	110	140	170	210	240
10	0.05	0.15	0.18	0.41	0.56	3.25	8.9	23.29
15	0.05	0.15	0.18	0.41	0.56	3.25	8.9	23.29
20	0.05	0.15	0.18	0.41	0.56	3.25	8.9	23.29
25	0.05	0.15	0.18	0.41	0.56	3.25	8.9	23.29
30	0.05	0.15	0.16	0.38	0.53	3.09	8.4	22.51
40	0.05	0.15	0.16	0.38	0.53	3.09	8.4	22.51
50	0.05	0.15	0.16	0.38	0.53	3.09	8.4	22.51



# ST-FO series

RATIO : 1.2.3.4.5 ( 1-Stage)

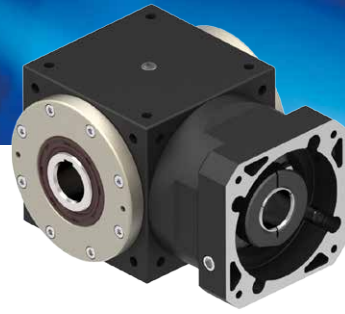

Input Flange - Hollow Output Shaft

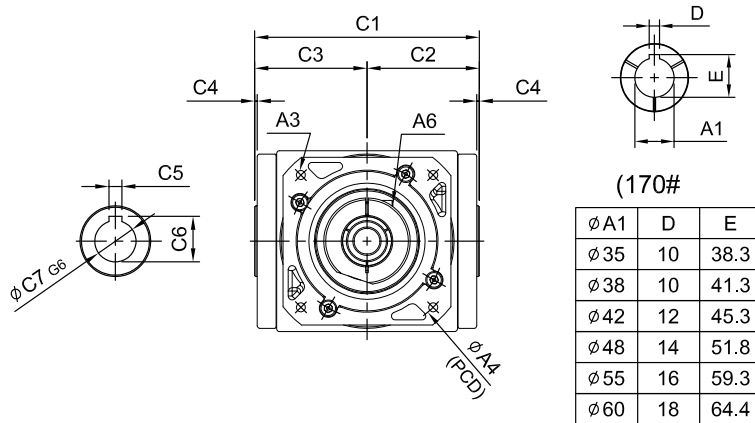
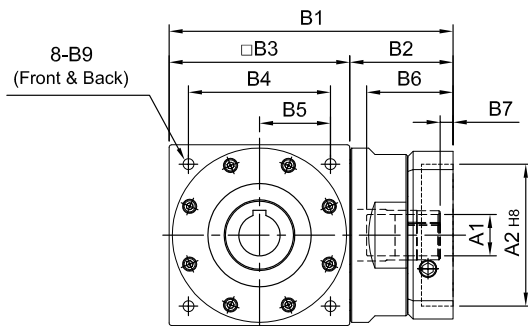
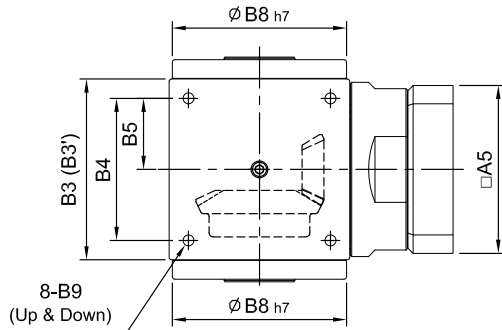

unit: mm

Model Code	65		65 (1:1)	75	90	110	140	170	210	240
	<b>A</b>	A1	9 · 11 · 14	14 · 19	16 · 19 · 22 · 24	19 · 22 · 24	24 · 28 · 32 · 35	35 · 38	35 · 38 · 42 · 48 · 55	48 · 55 · 60
	A2	50 · 60 · 70	50 · 60 · 70	70 · 80 · 95 · 110	70 · 80 · 95 · 110	95 · 110 · 130	110 · 130 · 180	114.3 · 180 · 230	114.3 · 230 · 250	
	A3	M4 · M5 · M6	M4 · M5 · M6	M5 · M6 · M8	M5 · M6 · M8	M6 · M8 · M10	M8 · M10 · M12	M10 · M12 · M16	M12 · M16	
	A4	70 · 75 · 90	70 · 75 · 90	90 · 100 · 115 · 145	90 · 100 · 115 · 145	115 · 145 · 165	145 · 165 · 200	200 · 215 · 265	200 · 265 · 300	
	A5	64 · 70 · 80	64 · 70 · 80	92 · 110 · 130	92 · 110 · 130	122 · 130 · 150	146 · 150 · 190	182 · 200 · 250	222 · 250 · 265	
	A6	M5 x P0.8	M5 x P0.8	M6 x P1.0	M6 x P1.0	M8 x P1.25	M10 x P1.5	M10 x P1.5	M10 x P1.5	
<b>B</b>	B1	110	115 · 122	148 · 162	177 · 191	224 · 238	274	357 · 359	394.5 · 421.5 · 424.5	
	B2	45	40	58 · 72	67 · 81	84 · 98	104	147	154.5 · 181.5 · 184.5	
	B3(B3')	65	75(74)	90	110	140	170	210	240	
	B4	52	60	72	88	110	134	170	190	
	B5	26	30	36	44	55	67	85	95	
	B6	36	36 · 43	51 · 65.5	51 · 65.5	68 · 81	84.5	117 · 119	115 · 142 · 145	
	B7	7	7 · 13	9 · 23.5	9 · 23.5	9 · 10	9.5	14 · 16	12.5 · 15.5	
	B8	62	64	73	88	106	135	164	228	
	B9	M5 x P0.8	M6 x P1.0	M6 x P1.0	M8 x P1.25	M10 x P1.5	M12 x P1.75	M16 x P2.0	M16 x P2.0	
<b>C</b>	C1	84	89	100	118	144	174	204	250	292
	C2	42	44.5	50	59	72	87	102	125	146
	C3	42	44.5	50	59	72	87	102	125	146
	C4	2	2	2	2	2	2	2	2	2
	C5	5	5	6	8	10	12	14	16	16
	C6	16.3	16.3	20.8	25.3	35.3	43.3	53.3	59.3	59.3
	C7	14	14	18	22	32	40	50	55	55
<b>Weight</b>		1.7	2.4	4.3	7.1	14.9	24.5	46		

# ST-RO series

RATIO : 10.15.20.25.30.40.50 ( 2-Stage)

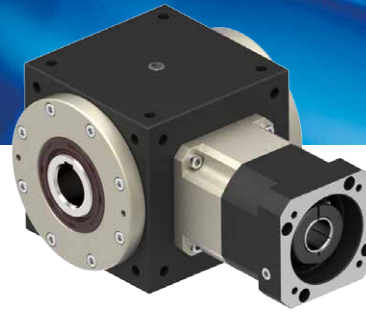

Fitted with Planetary Reducer - Hollow Output Shaft

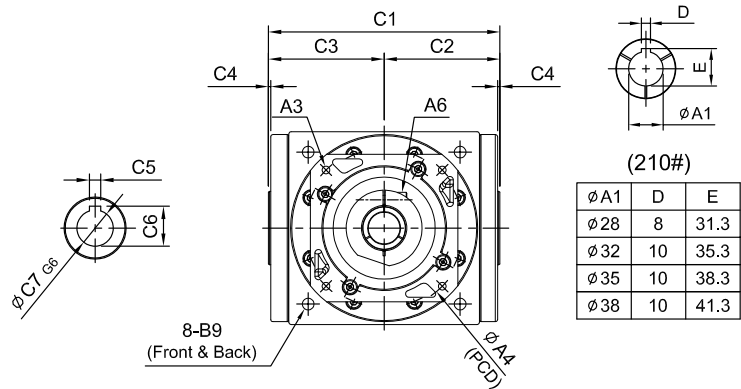
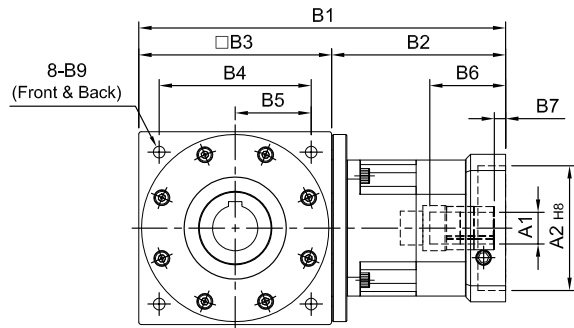
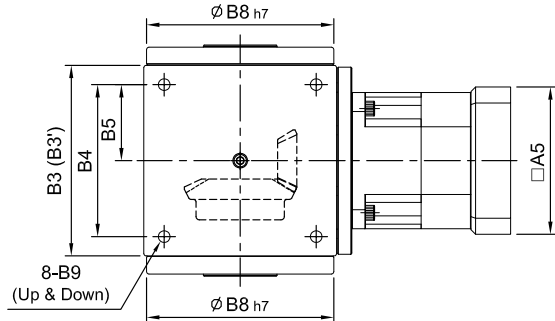

unit: mm

Model Code	65	75	90	110	140	170	210	240		
A	A1	8 · 9 · 11	8 · 9 · 11	11 · 14 · 16 · 19	11 · 14 · 16 · 19	(14) · 16 · 19	16 · 19 · 22 · 24	22 · 24 · 28 · 32 · 35	28 · 32 · 35 · 38	35 · 38 · 42 · 48 · 55
	A2	30 · 40 · 50	30 · 40 · 50	50 · 60 · 70	50 · 60 · 70	50 · 70 · 80 · 95	70 · 80 · 95 · 110	95 · 110 · 130	110 · 130 · 180	114.3 · 180 · 230 · 250
	A3	M3 · M4 · M5	M3 · M4 · M5	M4 · M5 · M6	M4 · M5 · M6	M5 · M6	M5 · M6 · M8	M6 · M8 · M10	M8 · M10 · M12	M10 · M12 · M16
	A4	46 · 60 · 63	46 · 60 · 63	70 · 75 · 90	70 · 75 · 90	70 · 90 · 100 · 115	90 · 100 · 115 · 145	115 · 145 · 165	145 · 165 · 200	200 · 215 · 265 · 300
	A5	46 · 55	46 · 55	64 · 70 · 80	64 · 70 · 80	80 · 92 · 110	92 · 110 · 130	122 · 130 · 150	146 · 150 · 190	182 · 200 · 250 · 265
	A6	M4 x P0.7	M4 x P0.7	M5 x P0.8	M5 x P0.8	M5 x P0.8	M6 x P1.0	M8 x P1.25	M10 x P1.5	M10 x P1.5
B	B1	132	137	149 · 157	165 · 173	(191) · 203	260	313 · 334	399	479.5
	B2	67	62	74 · 82	75 · 83	(81) · 93	120	143 · 164	189	239.5
	B3(B3')	65	75(74)	75(74)	90	110	140	170	210	240
	B4	52	60	60	72	88	110	134	170	190
	B5	26	30	30	36	44	55	67	85	95
	B6	26	26	33.5 · 41.5	33.5 · 41.5	(33.5) · 45.5	59	67 · 83	85	116.5
	B7	5	5	6	6	(6) · 10	9	10 · 11	10	13.5
	B8	62	73	73	88	106	135	164	205	228
B9	M5 x P0.8	M6 x P1.0	M6 x P1.0	M6 x P1.0	M8 x P1.25	M10 x P1.5	M12 x P1.75	M16 x P2.0	M16 x P2.0	
C	C1	84	100	100	118	144	174	204	250	292
	C2	42	50	50	59	72	87	102	125	146
	C3	42	50	50	59	72	87	102	125	146
	C4	2	2	2	2	2	2	2	2	2
	C5	5	5	5	6	8	10	12	14	16
	C6	16.3	16.3	16.3	20.8	25.3	35.3	43.3	53.3	59.3
	C7	14	14	14	18	22	32	40	50	55
Weight	1.9	3.6	3.4	4.8	8.5	14.2	24	52		

# ST-DO series

RATIO : 1.2.3.4.5 ( 1-Stage)

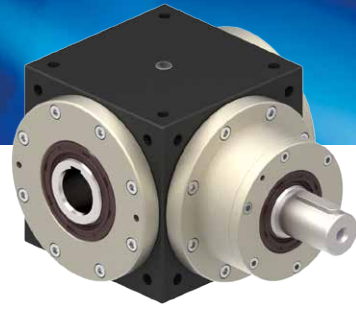

Single Input Shaft - Hollow Output Shaft

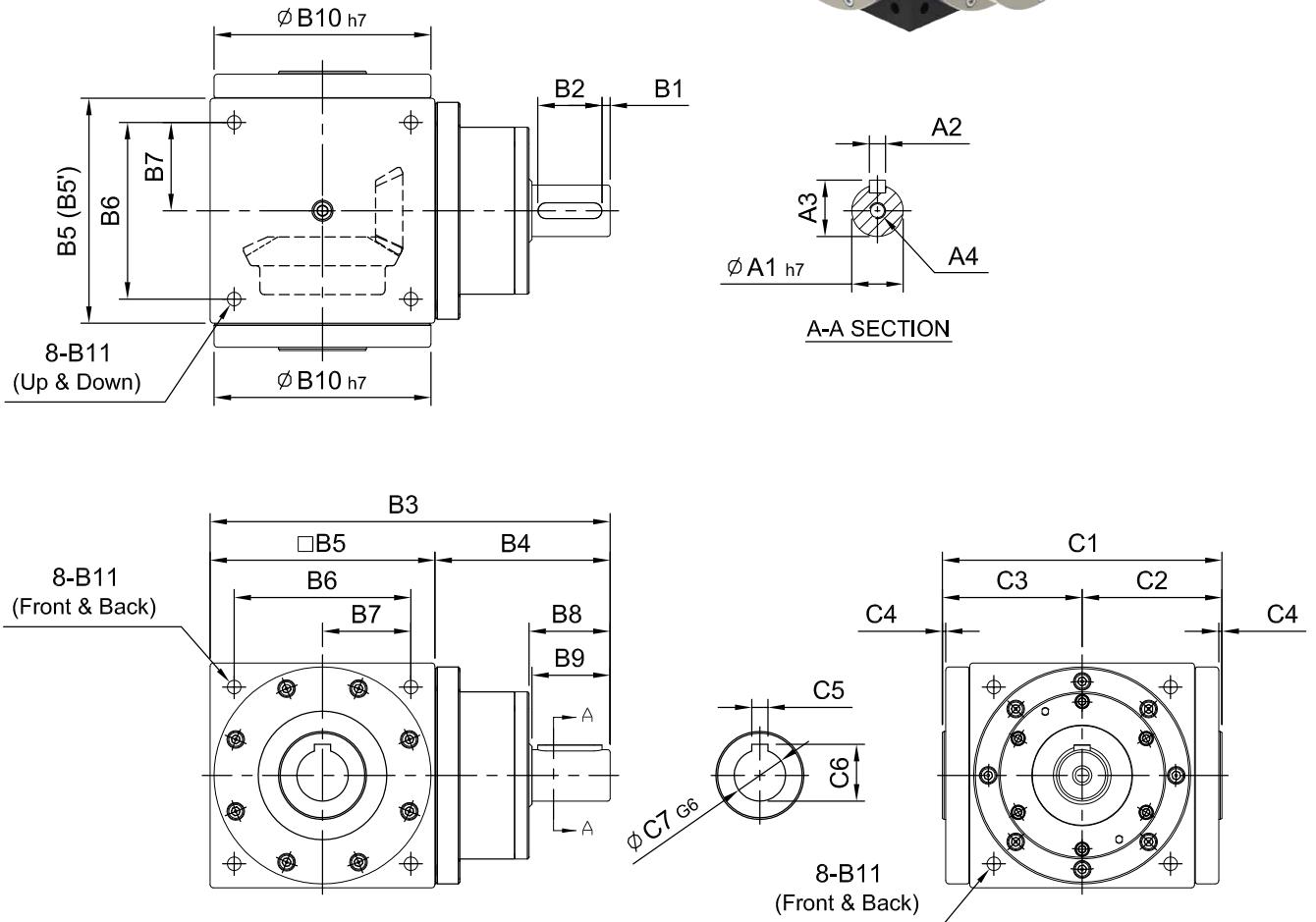

unit: mm

Model Code	65	65 (1:1)	75	90	110	140	170	210	240	
	<b>A</b>	A1	14	16	18	22	32	40	50	55
	A2	5	5	6	6	10	12	14	16	
	A3	16	18	20.5	24.5	35	43	53.5	59	
	A4	M5 x P0.8	M5 x P0.8	M8 x P1.25	M8 x P1.25	M10 x P1.5	M12 x P1.75	M12 x P1.75	M16 x P2.0	
<b>B</b>	B1	2.5	2.5	5	5	5	5	5	5	
	B2	15	25	25	30	40	50	65	70	
	B3	127.5	143	168.5	207	250	300	375	430	
	B4	62.5	68	78.5	97	110	130	165	190	
	B5(B5')	65	75(74)	90	110	140	170	210	240	
	B6	52	60	72	88	110	134	170	190	
	B7	26	30	36	44	55	67	85	95	
	B8	22	32	38	43	53.5	64	77	82	
	B9	20	30	35	40	50	60	75	80	
	B10	62	64	73	88	106	135	164	205	228
	B11	M5 x P0.8	M5 x P0.8	M6 x P1.0	M8 x P1.25	M10 x P1.5	M12 x P1.75	M16 x P2.0	M16 x P2.0	
<b>C</b>	C1	84	89	100	118	144	174	204	250	292
	C2	42	44.5	50	59	72	87	102	125	146
	C3	42	44.5	50	59	72	87	102	125	146
	C4	2	2	2	2	2	2	2	2	2
	C5	5	5	6	8	10	12	14	16	16
	C6	16.3	16.3	20.8	25.3	35.3	43.3	53.3	59.3	59.3
	C7	14	14	18	22	32	40	50	55	55
<b>Weight</b>		2.1	2.8	4.9	9	15.5	25	53		

# ST-YO series

RATIO : 1.2.3.4.5 ( 1-Stage)

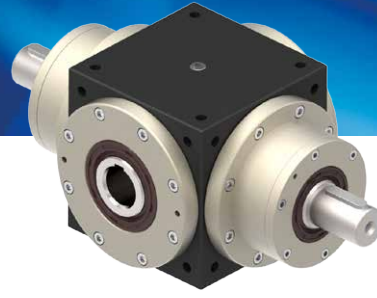

Double Input Shaft - Hollow Output Shaft

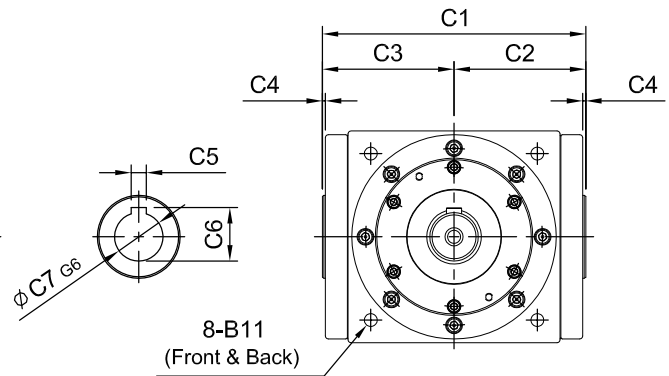
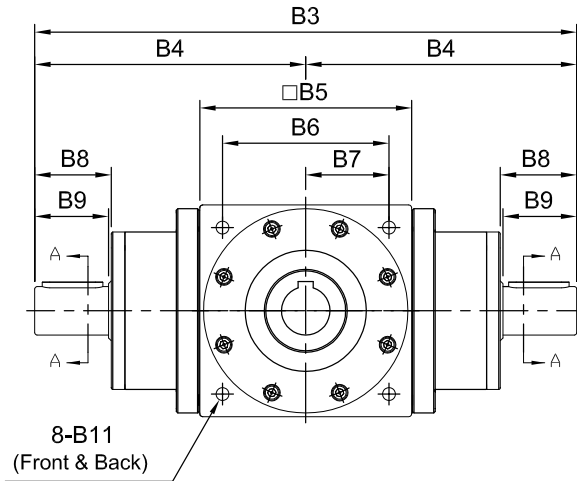
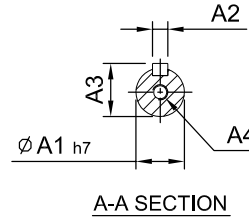
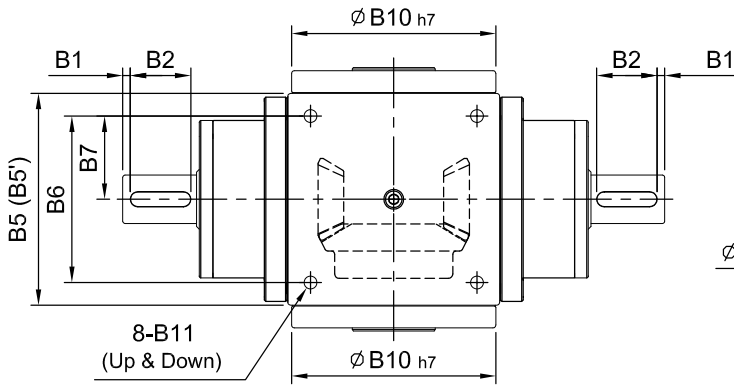

unit: mm

	Model Code	65	65 (1:1)	75	90	110	140	170	210	240
		<b>A</b>	A1	14	16	18	22	32	40	50
	A2	5	5	6	6	10	12	14	16	
	A3	16	18	20.5	24.5	35	43	53.5	59	
	A4	M5 x P0.8	M5 x P0.8	M8 x P1.25	M8 x P1.25	M10 x P1.5	M12 x P1.75	M12 x P1.75	M16 x P2.0	
<b>B</b>	B1	2.5	2.5	5	5	5	5	5	5	
	B2	15	25	25	30	40	50	65	70	
	B3	190	210	247	304	360	430	540	620	
	B4	95	105	123.5	152	180	215	270	310	
	B5(B5')	65	75(74)	90	110	140	170	210	240	
	B6	52	60	72	88	110	134	170	190	
	B7	26	30	36	44	55	67	85	95	
	B8	22	32	38	43	53.5	64	77	82	
	B9	20	30	35	40	50	60	75	80	
	B10	62	64	73	88	106	135	164	205	228
	B11	M5 x P0.8	M6 x P1.0	M6 x P1.0	M8 x P1.25	M10 x P1.5	M12 x P1.75	M16 x P2.0	M16 x P2.0	
<b>C</b>	C1	84	89	100	118	144	174	204	250	292
	C2	42	44.5	50	59	72	87	102	125	146
	C3	42	44.5	50	59	72	87	102	125	146
	C4	2	2	2	2	2	2	2	2	2
	C5	5	5	6	8	10	12	14	16	
	C6	16.3	16.3	20.8	25.3	35.3	43.3	53.3	59.3	
	C7	14	14	18	22	32	40	50	55	
<b>Weight</b>		2.85	3.6	6.2	11.5	18	28	57		

# ST-FN series

RATIO : 1.2.3.4.5 ( 1-Stage)

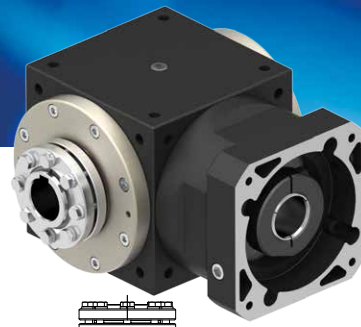

Input Flange - Single Clamping

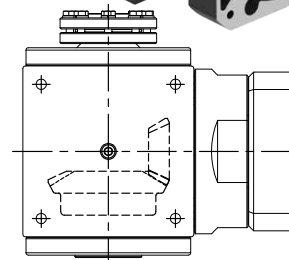
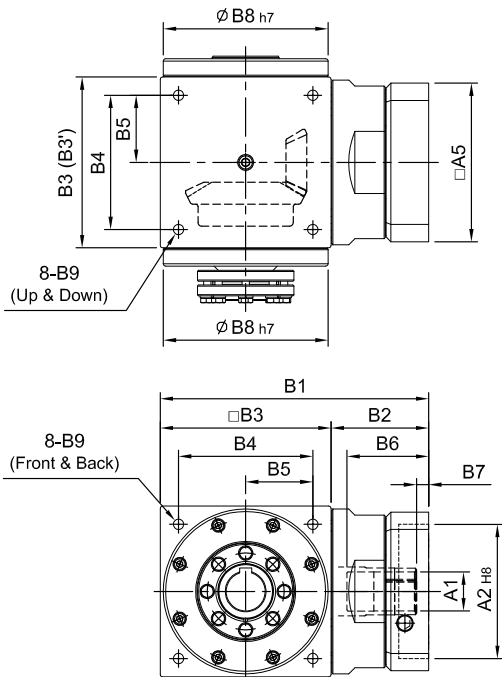

R  
Shaft Direction

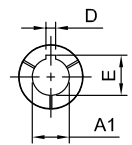
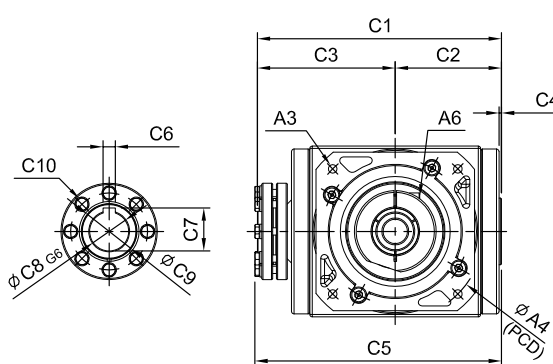

(170#)

ØA1	D	E
Ø35	10	38.3
Ø38	10	41.3
Ø42	12	45.3
Ø48	14	51.8
Ø55	16	59.3
Ø60	18	64.4

unit: mm

Model Code	65	65 (1:1)	75	90	110	140	170	210	240
	<b>A</b>	A1	9 · 11 · 14	14 · 19	16 · 19 · 22 · 24	19 · 22 · 24	24 · 28 · 32 · 35	35 · 38	35 · 38 · 42 · 48 · 55
	A2	50 · 60 · 70	50 · 60 · 70	70 · 80 · 95 · 110	70 · 80 · 95 · 110	95 · 110 · 130	110 · 130 · 180	114.3 · 180 · 230	114.3 · 230 · 250
	A3	M4 · M5 · M6	M4 · M5 · M6	M5 · M6 · M8	M5 · M6 · M8	M6 · M8 · M10	M8 · M10 · M12	M10 · M12 · M16	M12 · M16
	A4	70 · 75 · 90	70 · 75 · 90	90 · 100 · 115 · 145	90 · 100 · 115 · 145	115 · 145 · 165	145 · 165 · 200	200 · 215 · 265	200 · 265 · 300
	A5	64 · 70 · 80	64 · 70 · 80	92 · 110 · 130	92 · 110 · 130	122 · 130 · 150	146 · 150 · 190	182 · 200 · 250	222 · 250 · 265
	A6	M5 x P0.8	M5 x P0.8	M6 x P1.0	M6 x P1.0	M8 x P1.25	M10 x P1.5	M10 x P1.5	M10 x P1.5
<b>B</b>	B1	110	115 · 122	148 · 162	177 · 191	224 · 238	274	357 · 359	394.5 · 421.5 · 424.5
	B2	45	40	58 · 72	67 · 81	84 · 98	104	147	154.5 · 181.5 · 184.5
	B3(B3')	65	75(74)	90	110	140	170	210	240
	B4	52	60	72	88	110	134	170	190
	B5	26	30	36	44	55	67	85	95
	B6	36	36 · 43	51 · 65.5	51 · 65.5	68 · 81	84.5	117	115 · 142 · 145
	B7	7	7 · 13	9 · 23.5	9 · 23.5	9 · 10	9.5	14 · 16	12.5 · 15.5
	B8	62	64	73	88	106	135	164	228
	B9	M5 x P0.8	M6 x P1.0	M6 x P1.0	M8 x P1.25	M10 x P1.5	M12 x P1.75	M16 x P2.0	M16 x P2.0
<b>C</b>	C1	104	109	120	138	169	202	285	324
	C2	42	44.5	50	59	72	87	102	146
	C3	62	64.5	70	79	97	115	138	178
	C4	2	2	2	2	2	2	2	2
	C5	110	113	124	142	171	202	242	288
	C6	5	5	6	8	10	12	14	16
	C7	16.3	16.3	20.8	25.3	35.3	43.3	53.3	59.3
	C8	14	14	18	22	32	40	50	55
	C9	22	22	28	34	44	52	65	73
	C10	6-M6	6-M6	6-M6	8-M6	8-M6	8-M8	8-M8	8-M8
Weight		1.7	2.4	4.3	7.1	14.9	24.5	46	

# ST-RN series

RATIO : 10.15.20.25.30.40.50 ( 2-Stage)

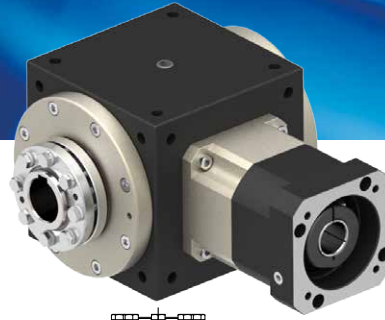

Fitted with Planetary Reducer - Single Clamping

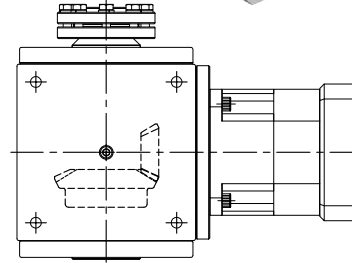
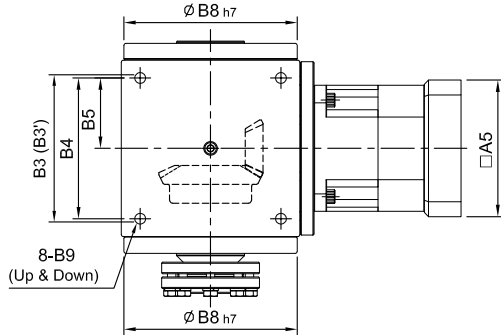

R  
Shaft Direction

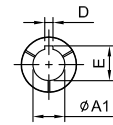
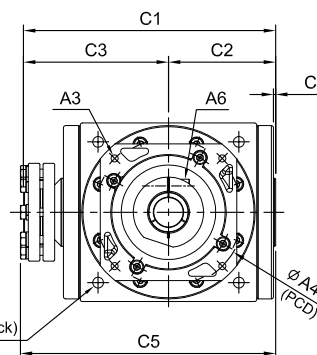
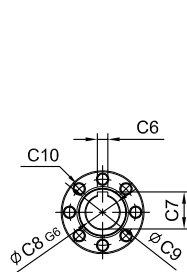
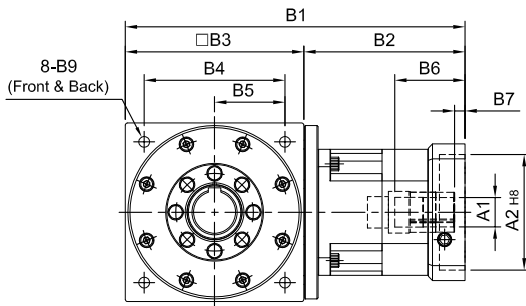

(210#)

$\phi A1$	D	E
$\phi 28$	8	31.3
$\phi 32$	10	35.3
$\phi 35$	10	38.3
$\phi 38$	10	41.3

unit: mm

Model Code	65	75	90	110	140	170	210	240		
A	A1	8 · 9 · 11	8 · 9 · 11	11 · 14 · 16 · 19	11 · 14 · 16 · 19	(14) · 16 · 19	16 · 19 · 22 · 24	22 · 24 · 28 · 32 · 35	28 · 32 · 35 · 38	35 · 38 · 42 · 48 · 55
	A2	30 · 40 · 50	30 · 40 · 50	50 · 60 · 70	50 · 60 · 70	50 · 70 · 80 · 95	70 · 80 · 95 · 110	95 · 110 · 130	110 · 130 · 180	114.3 · 180 · 230 · 250
	A3	M3 · M4 · M5	M3 · M4 · M5	M4 · M5 · M6	M4 · M5 · M6	M5 · M6	M5 · M6 · M8	M6 · M8 · M10	M8 · M10 · M12	M10 · M12 · M16
	A4	46 · 60 · 63	46 · 60 · 63	70 · 75 · 90	70 · 75 · 90	70 · 90 · 100 · 115	90 · 100 · 115 · 145	115 · 145 · 165	145 · 165 · 200	200 · 215 · 265 · 300
	A5	46 · 55	46 · 55	64 · 70 · 80	64 · 70 · 80	80 · 92 · 110	92 · 110 · 130	122 · 130 · 150	146 · 150 · 190	182 · 200 · 250 · 265
	A6	M4 x P0.7	M4 x P0.7	M5 x P0.8	M5 x P0.8	M5 x P0.8	M6 x P1.0	M8 x P1.25	M10 x P1.5	M10 x P1.5
B	B1	132	137	149 · 157	165 · 173	(191) · 203	260	313 · 334	399	479.5
	B2	67	62	74 · 82	75 · 83	(81) · 93	120	143 · 164	189	239.5
	B3(B3')	65	75(74)	75(74)	90	110	140	170	210	240
	B4	52	60	60	72	88	110	134	170	190
	B5	26	30	30	36	44	55	67	85	95
	B6	26	26	33.5 · 41.5	33.5 · 41.5	(33.5) · 45.5	59	67 · 83	85	116.5
	B7	5	5	6	6	(6) · 10	9	10 · 11	10	13.5
	B8	62	73	73	88	106	135	164	205	228
	B9	M5 x P0.8	M6 x P1.0	M6 x P1.0	M6 x P1.0	M8 x P1.25	M10 x P1.5	M12 x P1.75	M16 x P2.0	M16 x P2.0
C	C1	104	120	120	138	169	200	240	285	324
	C2	42	50	50	59	72	87	102	125	146
	C3	62	70	70	79	97	113	138	160	178
	C4	2	2	2	2	2	2	2	2	2
	C5	118	124	124	142	171	202	242	288	329
	C6	5	5	5	6	8	10	12	14	16
	C7	16.3	16.3	16.3	20.8	25.3	35.3	43.3	53.3	59.3
	C8	14	14	14	18	22	32	40	50	55
	C9	22	22	22	28	34	44	52	65	73
	C10	6-M6	6-M6	6-M6	6-M6	8-M6	8-M6	8-M8	8-M8	8-M8
Weight	1.9	3.6	3.4	4.8	8.5	14.2	24	52		

# ST-DN series

RATIO : 1.2.3.4.5 ( 1-Stage)

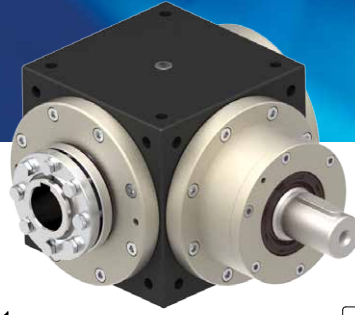

Single Input Shaft - Single Clamping

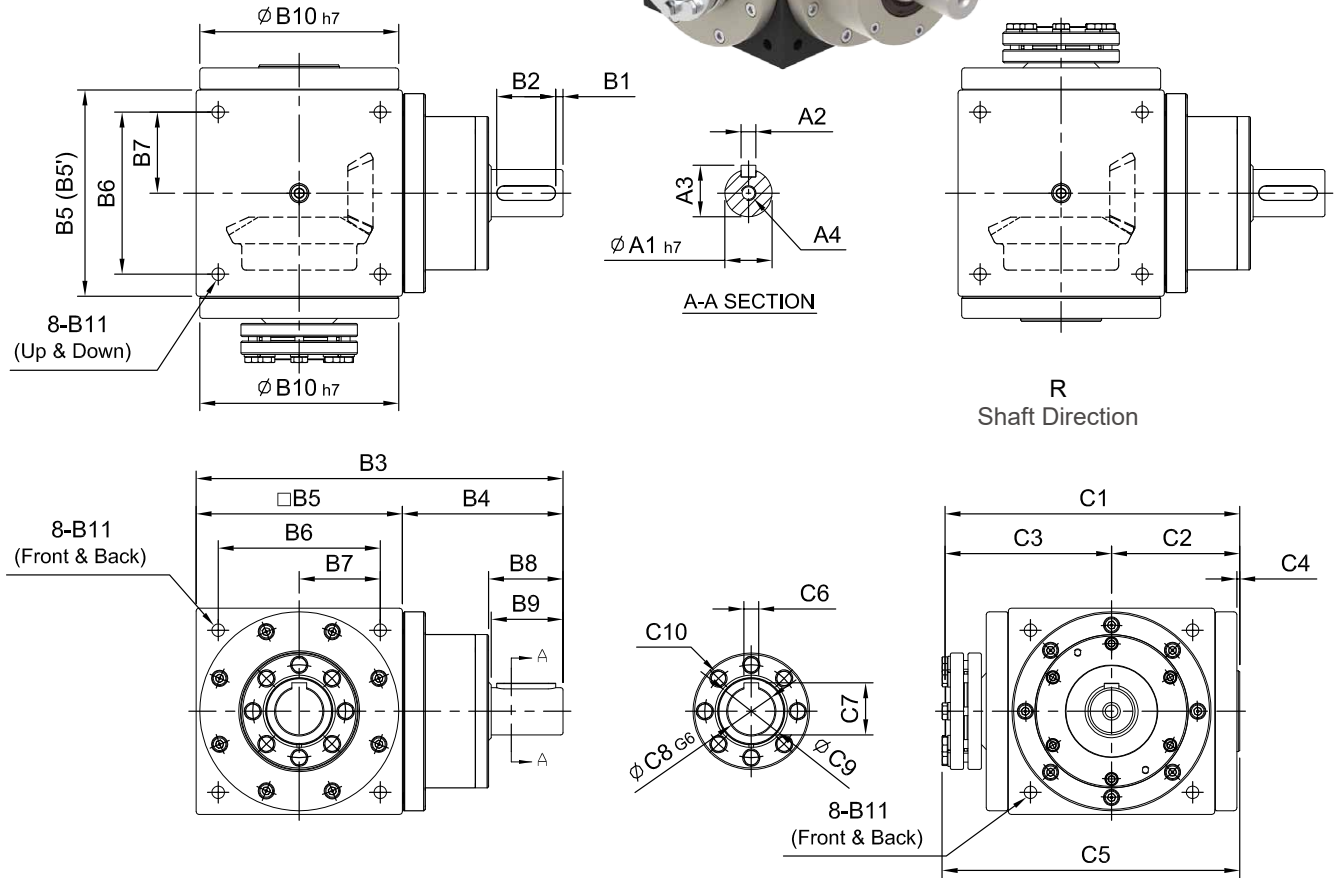

unit: mm

Model Code	65		65 (1:1)	75	90	110	140	170	210	240
	<b>A</b>	A1	14	16	18	22	32	40	50	55
	A2	5	5	6	6	10	12	14	16	
	A3	16	18	20.5	24.5	35	43	53.5	59	
	A4	M5 x P0.8	M5 x P0.8	M8 x P1.25	M8 x P1.25	M10 x P1.5	M12 x P1.75	M12 x P1.75	M16 x P2.0	
<b>B</b>	B1	2.5	2.5	5	5	5	5	5	5	
	B2	15	25	25	30	40	50	65	70	
	B3	127.5	143	168.5	207	250	300	375	430	
	B4	62.5	68	78.5	97	110	130	165	190	
	B5(B5')	65	75(74)	90	110	140	170	210	240	
	B6	52	60	72	88	110	134	170	190	
	B7	26	30	36	44	55	67	85	95	
	B8	22	32	38	43	53.5	64	77	82	
	B9	20	30	35	40	50	60	75	80	
	B10	62	64	73	88	106	135	164	205	228
	B11	M5 x P0.8	M6 x P1.0	M6 x P1.0	M8 x P1.25	M10 x P1.5	M12 x P1.75	M16 x P2.0	M16 x P2.0	
<b>C</b>	C1	104	109	120	138	169	202	240	285	324
	C2	42	44.5	50	59	72	87	102	125	146
	C3	62	64.5	70	79	97	115	138	160	178
	C4	2	2	2	2	2	2	2	2	2
	C5	110	113	124	142	171	202	242	288	329
	C6	5	5	6	8	10	12	14	16	
	C7	16.3	16.3	20.8	25.3	35.3	43.3	53.3	59.3	
	C8	14	14	18	22	32	40	50	55	
	C9	22	22	28	34	44	52	65	73	
	C10	6-M6	6-M6	6-M6	8-M6	8-M6	8-M8	8-M8	8-M8	
<b>Weight</b>		2.1	2.8	4.9	8.59	15.5	25	53		

ST

# ST-YN series

RATIO : 1.2.3.4.5 ( 1-Stage)



Double Input Shaft - Single Clamping

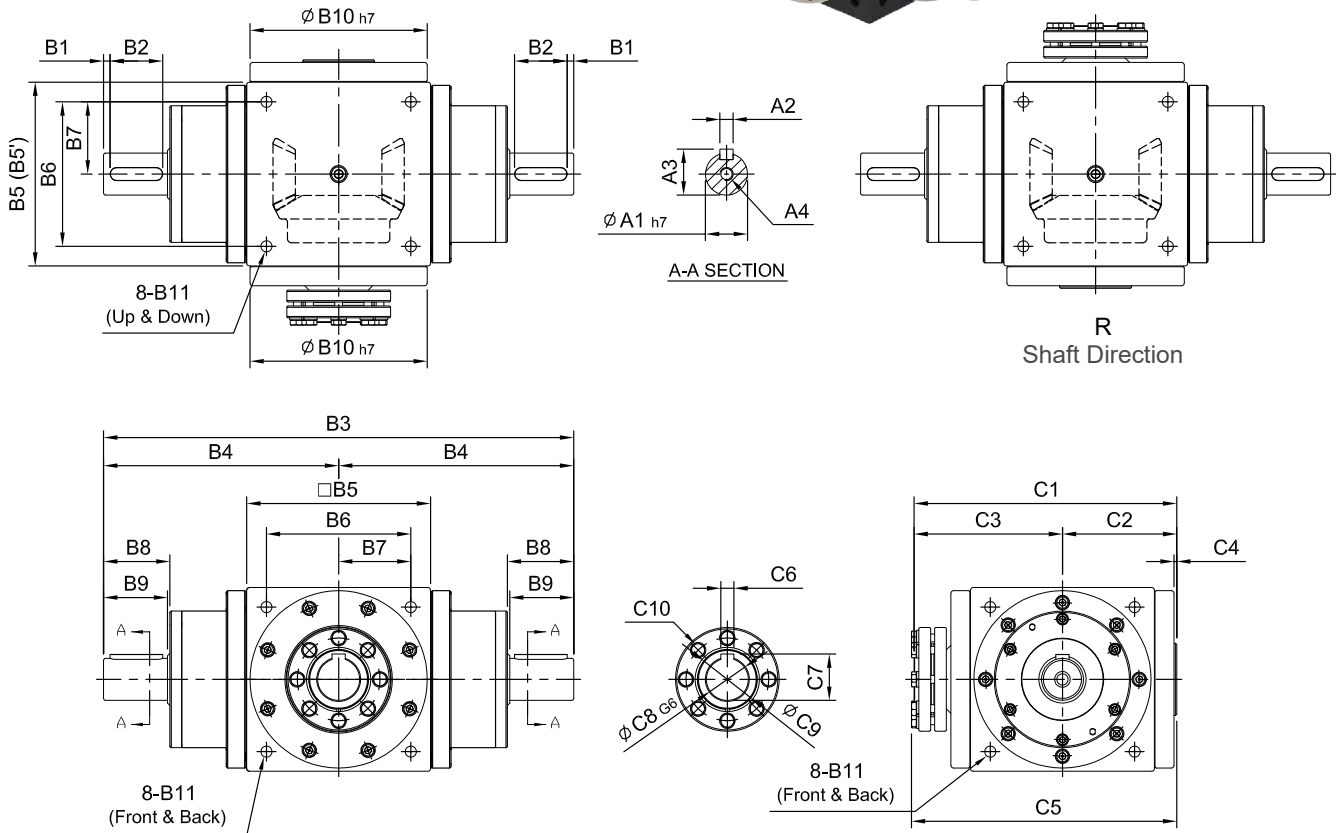

unit: mm

	Model Code	65	65 (1:1)	75	90	110	140	170	210	240
		<b>A</b>	A1	14	16	18	22	32	40	50
	A2	5	5	6	6	10	12	14	16	
	A3	16	18	20.5	24.5	35	43	53.5	59	
	A4	M5 x P0.8	M5 x P0.8	M8 x P1.25	M8 x P1.25	M10 x P1.5	M12 x P1.75	M12 x P1.75	M16 x P2.0	
<b>B</b>	B1	2.5	2.5	5	5	5	5	5	5	
	B2	15	25	25	30	40	50	65	70	
	B3	190	210	247	304	360	430	540	620	
	B4	95	105	123.5	152	180	215	270	310	
	B5(B5')	65	75(74)	90	110	140	170	210	240	
	B6	52	60	72	88	110	134	170	190	
	B7	26	30	36	44	55	67	85	95	
	B8	22	32	38	43	53.5	64	77	82	
	B9	20	30	35	40	50	60	75	80	
	B10	62	64	73	88	106	135	164	205	228
	B11	M5 x P0.8	M6 x P1.0	M6 x P1.0	M8 x P1.25	M10 x P1.5	M12 x P1.75	M16 x P2.0	M16 x P2.0	
<b>C</b>	C1	104	109	120	138	169	200	240	285	324
	C2	42	44.5	50	59	72	87	102	125	146
	C3	62	64.5	70	79	97	113	138	160	178
	C4	2	2	2	2	2	2	2	2	2
	C5	110	113	124	142	171	202	242	288	329
	C6	5	5	6	8	10	12	14	16	
	C7	16.3	16.3	20.8	25.3	35.3	43.3	53.3	59.3	
	C8	14	14	18	22	32	40	50	55	
	C9	22	22	28	34	44	52	65	73	
	C10	6-M6	6-M6	6-M6	8-M6	8-M6	8-M8	8-M8	8-M8	8-M8
Weight		2.85	3.6	6.2	11.5	18	28	57		



# ST-FM series

RATIO : 1.2.3.4.5 ( 1-Stage)



Input Flange - Double Clamping

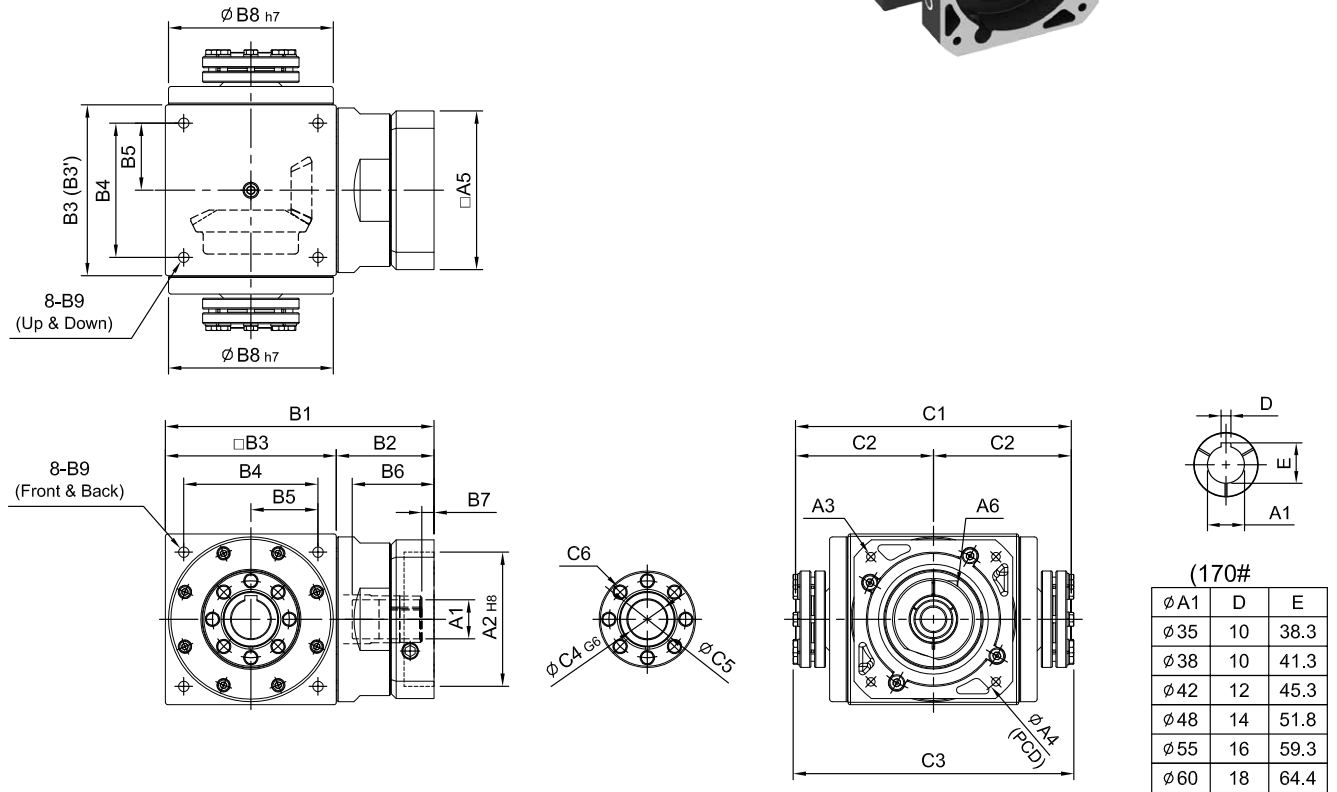

unit: mm

Model Code	65	65 (1:1)	75	90	110	140	170	210	240
	<b>A</b>	A1	9 · 11 · 14	14 · 19	16 · 19 · 22 · 24	19 · 22 · 24	24 · 28 · 32 · 35	35 · 38	35 · 38 · 42 · 48 · 55
	A2	50 · 60 · 70	50 · 60 · 70	70 · 80 · 95 · 110	70 · 80 · 95 · 110	95 · 110 · 130	110 · 130 · 180	114.3 · 180 · 230	114.3 · 230 · 250
	A3	M4 · M5 · M6	M4 · M5 · M6	M5 · M6 · M8	M5 · M6 · M8	M6 · M8 · M10	M8 · M10 · M12	M10 · M12 · M16	M12 · M16
	A4	70 · 75 · 90	70 · 75 · 90	90 · 100 · 115 · 145	90 · 100 · 115 · 145	115 · 145 · 165	145 · 165 · 200	200 · 215 · 265	200 · 265 · 300
	A5	64 · 70 · 80	64 · 70 · 80	92 · 110 · 130	92 · 110 · 130	122 · 130 · 150	146 · 150 · 190	182 · 200 · 250	222 · 250 · 265
	A6	M5 x P0.8	M5 x P0.8	M6 x P1.0	M6 x P1.0	M8 x P1.25	M10 x P1.5	M10 x P1.5	M10 x P1.5
<b>B</b>	B1	110	115 · 122	148 · 162	177 · 191	224 · 238	274	357 · 359	394.5 · 421.5 · 424.5
	B2	45	40	58 · 72	67 · 81	84 · 98	104	147	154.5 · 181.5 · 184.5
	B3(B3')	65	75(74)	90	110	140	170	210	240
	B4	52	60	72	88	110	134	170	190
	B5	26	30	36	44	55	67	85	95
	B6	36	36 · 43	51 · 65.5	51 · 65.5	68 · 81	84.5	117	115 · 142 · 145
	B7	7	7 · 13	9 · 23.5	9 · 23.5	9 · 10	9.5	14 · 16	12.5 · 15.5
	B8	62	64	73	88	106	135	205	228
	B9	M5 x P0.8	M6 x P1.0	M6 x P1.0	M8 x P1.25	M10 x P1.5	M12 x P1.75	M16 x P2.0	M16 x P2.0
<b>C</b>	C1	124	129	140	158	194	276	320	356
	C2	62	64.5	70	79	97	138	160	178
	C3	136	138	150	166	198	280	327	370
	C4	14	14	18	22	32	40	50	55
	C5	22	22	28	34	44	52	65	73
	C6	6-M6	6-M6	6-M6	8-M6	8-M6	8-M8	8-M8	8-M8
Weight		1.7	2.4	4.3	7.1	14.9	24.5	46	

# ST-RM series

RATIO : 10.15.20.25.30.40.50 ( 2-Stage)



Fitted with Planetary Reducer - Double Clamping

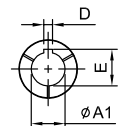
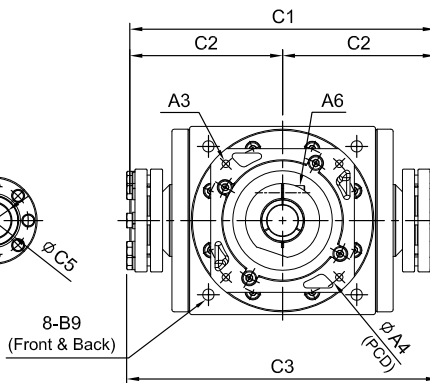
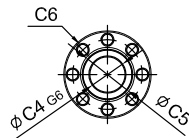
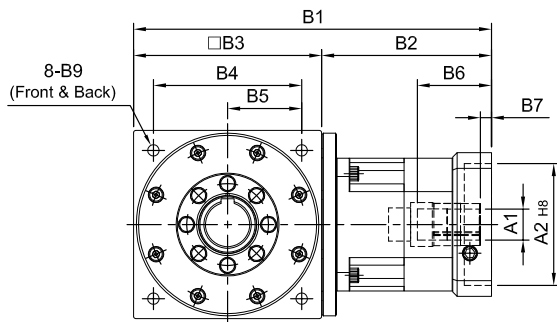
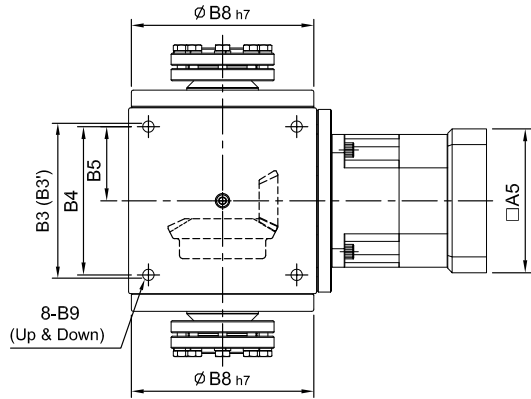

(210#)

$\phi A1$	D	E
$\phi 28$	8	31.3
$\phi 32$	10	35.3
$\phi 35$	10	38.3
$\phi 38$	10	41.3

unit: mm

Model Code	65	75	90	110	140	170	210	240		
A	A1	8 · 9 · 11	8 · 9 · 11	11 · 14 · 16 · 19	11 · 14 · 16 · 19	(14) · 16 · 19	16 · 19 · 22 · 24	22 · 24 · 28 · 32 · 35	28 · 32 · 35 · 38	35 · 38 · 42 · 48 · 55
	A2	30 · 40 · 50	30 · 40 · 50	50 · 60 · 70	50 · 60 · 70	50 · 70 · 80 · 95	70 · 80 · 95 · 110	95 · 110 · 130	110 · 130 · 180	114.3 · 180 · 230 · 250
	A3	M3 · M4 · M5	M3 · M4 · M5	M4 · M5 · M6	M4 · M5 · M6	M5 · M6	M5 · M6 · M8	M6 · M8 · M10	M8 · M10 · M12	M10 · M12 · M16
	A4	46 · 60 · 63	46 · 60 · 63	70 · 75 · 90	70 · 75 · 90	70 · 90 · 100 · 115	90 · 100 · 115 · 145	115 · 145 · 165	145 · 165 · 200	200 · 215 · 265 · 300
	A5	46 · 55	46 · 55	64 · 70 · 80	64 · 70 · 80	80 · 92 · 110	92 · 110 · 130	122 · 130 · 150	146 · 150 · 190	182 · 200 · 250 · 265
	A6	M4 x P0.7	M4 x P0.7	M5 x P0.8	M5 x P0.8	M5 x P0.8	M6 x P1.0	M8 x P1.25	M10 x P1.5	M10 x P1.5
B	B1	132	137	149 · 157	165 · 173	(191) · 203	260	313 · 334	399	479.5
	B2	67	62	74 · 82	75 · 83	(81) · 93	120	143 · 164	189	239.5
	B3(B3')	65	75(74)	75(74)	90	110	140	170	210	240
	B4	52	60	60	72	88	110	134	170	190
	B5	26	30	30	36	44	55	67	85	95
	B6	26	26	33.5 · 41.5	33.5 · 41.5	(33.5) · 45.5	59	67 · 83	85	116.5
	B7	5	5	5	6	(6) · 10	9	10 · 11	10	13.5
	B8	62	73	73	88	106	135	164	205	228
B9	M5 x P0.8	M6 x P1.0	M6 x P1.0	M6 x P1.0	M8 x P1.25	M10 x P1.5	M12 x P1.75	M16 x P2.0	M16 x P2.0	
C	C1	124	140	140	158	194	230	276	320	356
	C2	62	70	70	79	97	115	138	160	178
	C3	136	150	150	166	198	232	280	327	370
	C4	14	14	14	18	22	32	40	50	55
	C5	22	22	22	28	34	44	52	65	73
	C6	6-M6	6-M6	6-M6	6-M6	8-M6	8-M6	8-M8	8-M8	8-M8
Weight	1.9	3.6	3.4	4.8	8.5	14.2	24	52		

# ST-DM series

RATIO : 1.2.3.4.5 ( 1-Stage)



Single Input Shaft - Double Clamping

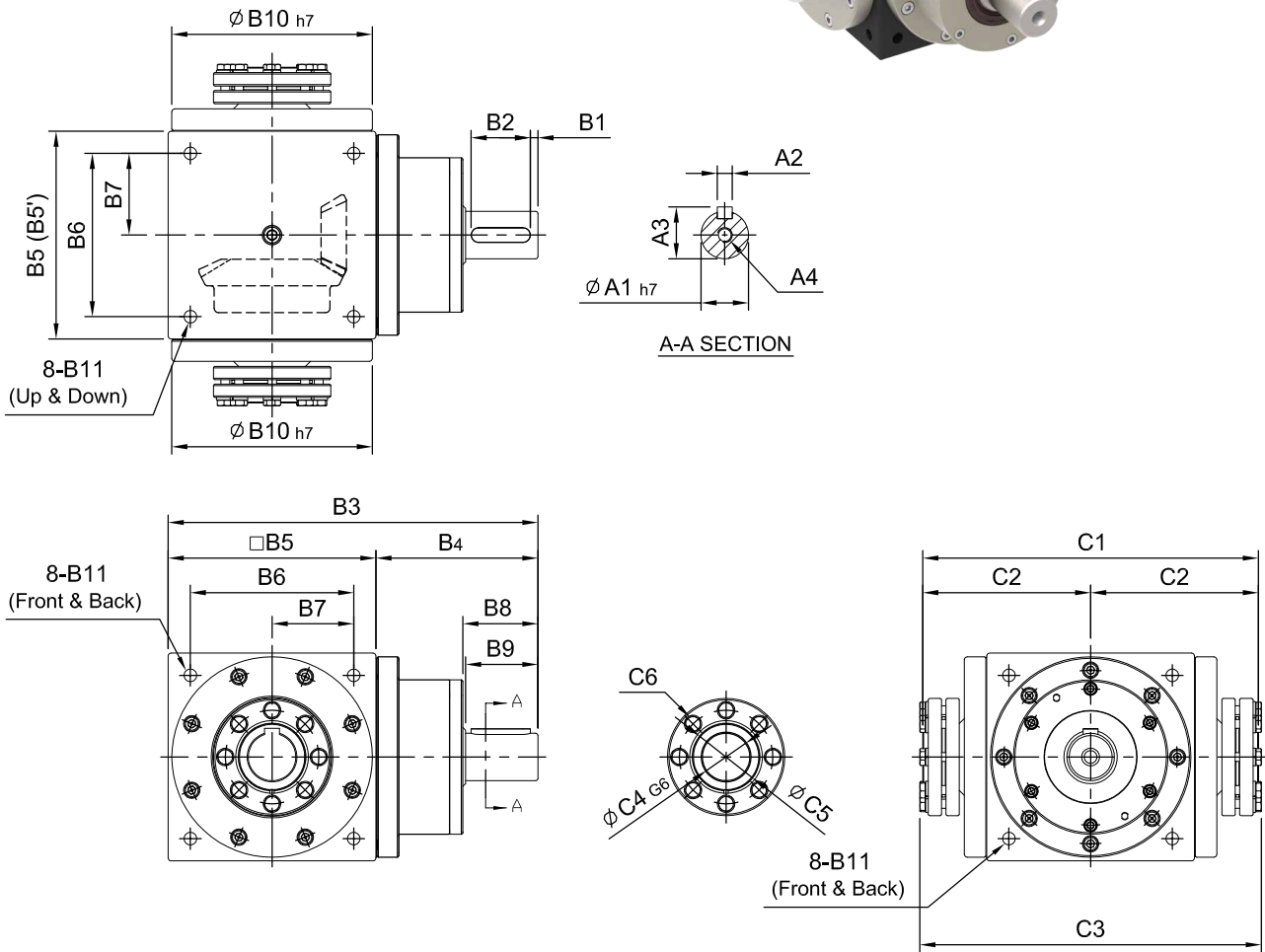

unit: mm

	Model Code	unit: mm								
		65	65 (1:1)	75	90	110	140	170	210	240
<b>A</b>	A1	14		16	18	22	32	40	50	55
	A2	5		5	6	6	10	12	14	16
	A3	16		18	20.5	24.5	35	43	53.5	59
	A4	M5 x P0.8		M5 x P0.8	M8 x P1.25	M8 x P1.25	M10 x P1.5	M12 x P1.75	M12 x P1.75	M16 x P2.0
<b>B</b>	B1	2.5		2.5	5	5	5	5	5	5
	B2	15		25	25	30	40	50	65	70
	B3	127.5		143	168.5	207	250	300	375	430
	B4	62.5		68	78.5	97	110	130	165	190
	B5(B5')	65		75(74)	90	110	140	170	210	240
	B6	52		60	72	88	110	134	170	190
	B7	26		30	36	44	55	67	85	95
	B8	22		32	38	43	53.5	64	77	82
	B9	20		30	35	40	50	60	75	80
	B10	62	64	73	88	106	135	164	205	228
B11	M5 x P0.8		M6 x P1.0	M6 x P1.0	M8 x P1.25	M10 x P1.5	M12 x P1.75	M16 x P2.0	M16 x P2.0	
<b>C</b>	C1	124	129	140	158	194	230	276	320	356
	C2	62	64.5	70	79	97	115	138	160	178
	C3	136	138	150	166	198	232	280	327	370
	C4	14		14	18	22	32	40	50	55
	C5	22		22	28	34	44	52	65	73
	C6	6-M6		6-M6	6-M6	8-M6	8-M6	8-M8	8-M8	8-M8
Weight		2.1		2.8	4.9	8.59	15.5	25	53	

# ST-YM series

RATIO : 1.2.3.4.5 ( 1-Stage)



Double Input Shaft - Double Clamping

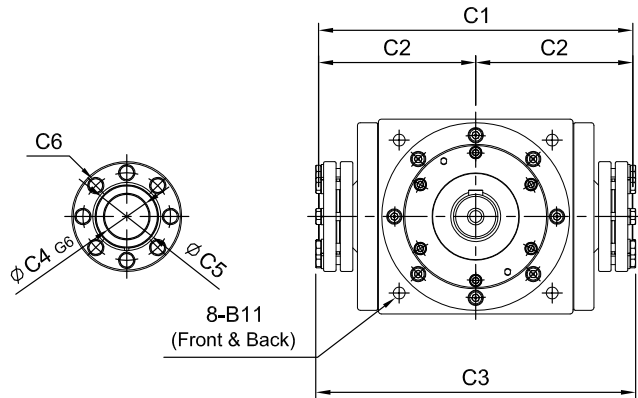
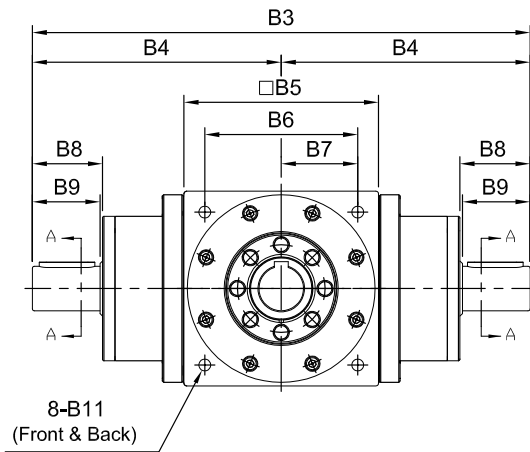
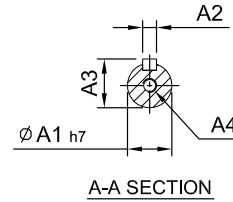
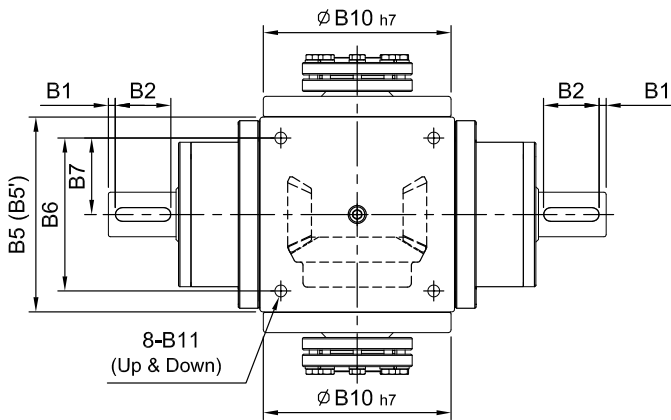

unit: mm

	Model Code	65	65 (1:1)	75	90	110	140	170	210	240
		<b>A</b>	A1	14	16	18	22	32	40	50
	A2	5	5	6	6	10	12	14	16	
	A3	16	18	20.5	24.5	35	43	53.5	59	
	A4	M5 x P0.8	M5 x P0.8	M8 x P1.25	M8 x P1.25	M10 x P1.5	M12 x P1.75	M12 x P1.75	M16 x P2.0	
<b>B</b>	B1	2.5	2.5	5	5	5	5	5	5	
	B2	15	25	25	30	40	50	65	70	
	B3	190	210	247	304	360	430	540	620	
	B4	95	95	123.5	152	180	215	270	310	
	B5(B5')	65	75(74)	90	110	140	170	210	240	
	B6	52	60	72	88	110	134	170	190	
	B7	26	30	36	44	55	67	85	95	
	B8	22	32	38	43	53.5	64	77	82	
	B9	20	30	35	40	50	60	75	80	
	B10	62	64	73	88	106	135	164	205	228
	B11	M5 x P0.8	M6 x P1.0	M6 x P1.0	M8 x P1.25	M10 x P1.5	M12 x P1.75	M16 x P2.0	M16 x P2.0	
<b>C</b>	C1	124	129	140	158	194	230	276	320	356
	C2	62	64.5	70	79	97	115	138	160	178
	C3	136	138	150	166	198	232	280	327	370
	C4	14	14	18	22	32	40	50	55	
	C5	22	22	28	34	44	52	65	73	
	C6	6-M6	6-M6	6-M6	8-M6	8-M6	8-M8	8-M8	8-M8	8-M8
Weight		2.85	3.6	6.2	11.5	18	28	57		

# ST-FS series

RATIO : 1.2.3.4.5 ( 1-Stage)

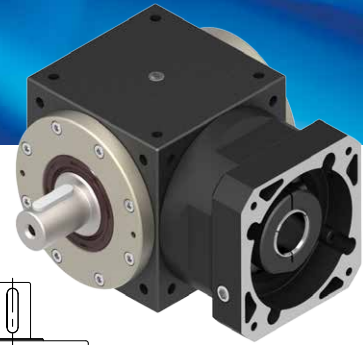

Input Flange - Single Output Shaft

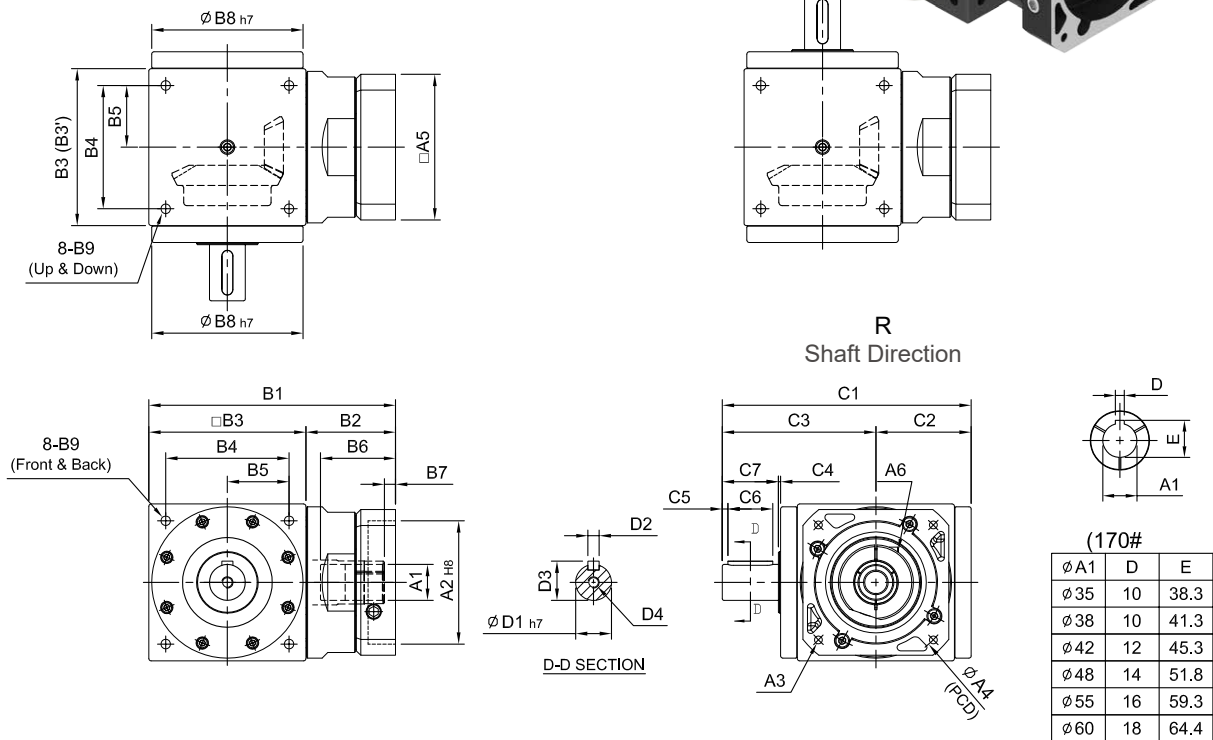

unit: mm

	Model Code	65	65 (1:1)	75	90	110	140	170	210	240
		<b>A</b>	A1	9 · 11 · 14	14 · 19	16 · 19 · 22 · 24	19 · 22 · 24	24 · 28 · 32 · 35	35 · 38	35 · 38 · 42 · 48 · 55
	A2	50 · 60 · 70	50 · 60 · 70	70 · 80 · 95 · 110	70 · 80 · 95 · 110	95,110,130	110,130,180	114.3 · 180 · 230	114.3 · 230 · 250	
	A3	M4 · M5 · M6	M4 · M5 · M6	M5 · M6 · M8	M5 · M6 · M8	M6 · M8 · M10	M8 · M10 · M12	M10 · M12 · M16	M12 · M16	
	A4	70 · 75 · 90	70 · 75 · 90	90 · 100 · 115 · 145	90 · 100 · 115 · 145	115 · 145 · 165	145 · 165 · 200	200 · 215 · 265	200 · 265 · 300	
	A5	64 · 70 · 80	64 · 70 · 80	92 · 110 · 130	92 · 110 · 130	122 · 130 · 150	146 · 150 · 190	182 · 200 · 250	222 · 250 · 265	
	A6	M5 x P0.8	M5 x P0.8	M6 x P1.0	M6 x P1.0	M8 x P1.25	M10 x P1.5	M10 x P1.5	M10 x P1.5	
<b>B</b>	B1	110	115 · 122	148 · 162	177 · 191	224 · 238	274	357 · 359	394.5 · 421.5 · 424.5	
	B2	45	40	58 · 72	67 · 81	84 · 98	104	147	154.5 · 181.5 · 184.5	
	B3(B3')	65	75(74)	90	110	140	170	210	240	
	B4	52	60	72	88	110	134	170	190	
	B5	26	30	36	44	55	67	85	95	
	B6	36	36 · 43	51 · 65.5	51 · 65.5	68 · 81	84.5	117	115 · 142 · 145	
	B7	7	7 · 13	9 · 23.5	9 · 23.5	9 · 10	9.5	14 · 16	12.5 · 15.5	
	B8	62   64	73	88	106	135	164	205	228	
	B9	M5 x P0.8	M6 x P1.0	M6 x P1.0	M8 x P1.25	M10 x P1.5	M12 x P1.75	M16 x P2.0	M16 x P2.0	
<b>C</b>	C1	102	107	128	151	182	222	262	323	370
	C2	40	42.5	48	57	70	85	100	123	144
	C3	62	64.5	80	94	112	137	162	200	226
	C4	2	2	2	2	2	2	2	2	2
	C5	2.5	2.5	5	5	5	5	5	5	5
	C6	15	25	25	30	40	50	65	70	70
	C7	20	30	35	40	50	60	75	80	80
<b>D</b>	D1	14	16	18	22	32	40	50	55	55
	D2	5	5	6	6	10	12	14	16	16
	D3	16	18	20.5	24.5	35	43	53.5	59	59
	D4	M5 x P0.8	M5 x P0.8	M5 x P0.8	M5 x P0.8	M10 x P1.5	M12 x P1.75	M12 x P1.75	M16 x P2.0	M16 x P2.0
<b>Weight</b>		1.7	2.4	4.3	7.1	14.9	24.5	46		

# ST-RS series

RATIO : 10.15.20.25.30.40.50 ( 2-Stage)

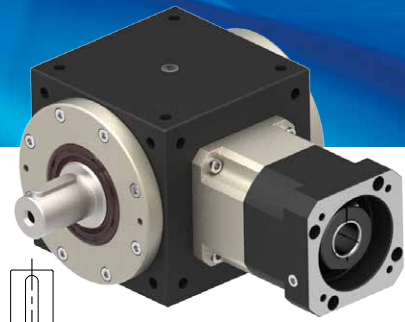

Fitted with Planetary Reducer - Single Output Shaft

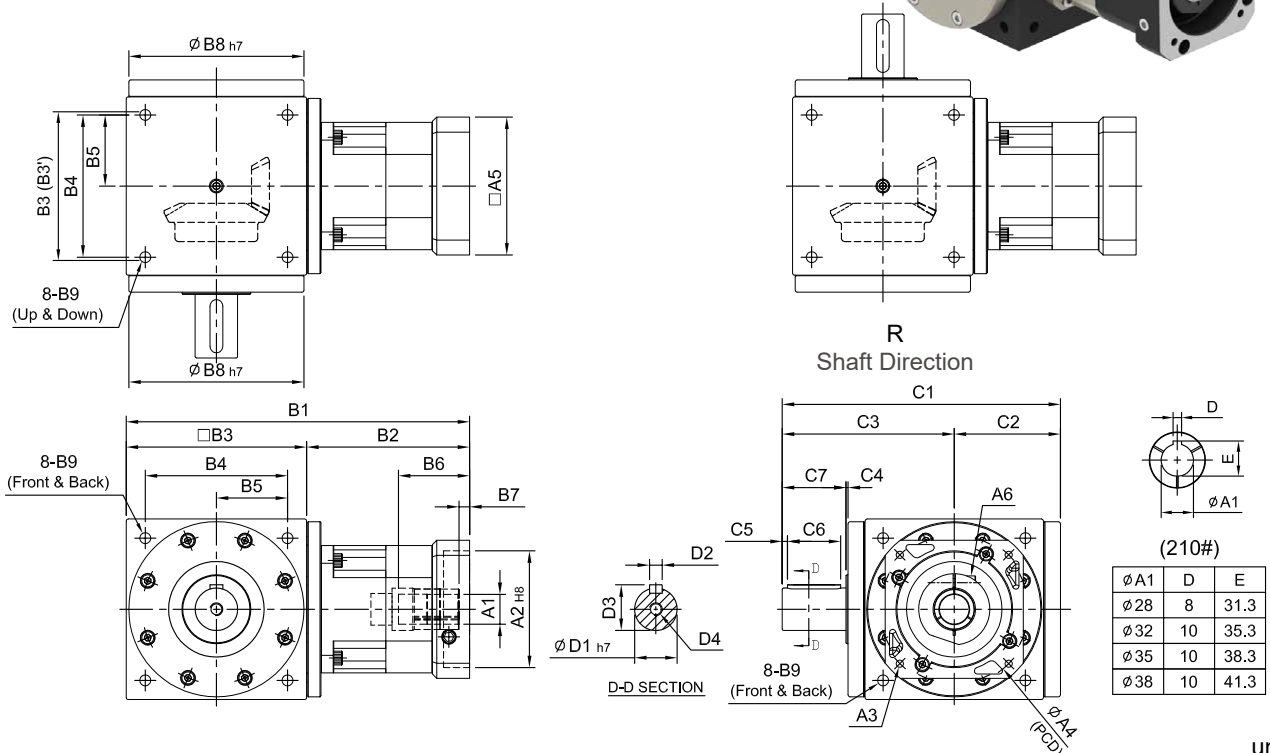

		unit: mm								
Model Code		65	75	90	110	140	170	210	240	
		<b>A</b>	A1	8 · 9 · 11	8 · 9 · 11	11 · 14 · 16 · 19	11 · 14 · 16 · 19	(14) · 16 · 19	16 · 19 · 22 · 24	22 · 24 · 28 · 32 · 35
	A2	30 · 40 · 50	30 · 40 · 50	50 · 60 · 70	50 · 60 · 70	50 · 70 · 80 · 95	70 · 80 · 95 · 110	95 · 110 · 130	110 · 130 · 180	114.3 · 180 · 230 · 250
	A3	M3 · M4 · M5	M3 · M4 · M5	M4 · M5 · M6	M4 · M5 · M6	M5 · M6	M5 · M6 · M8	M6 · M8 · M10	M8 · M10 · M12	M10 · M12 · M16
	A4	46 · 60 · 63	46 · 60 · 63	70 · 75 · 90	70 · 75 · 90	70 · 90 · 100 · 115	90 · 100 · 115 · 145	115 · 145 · 165	145 · 165 · 200	200 · 215 · 265 · 300
	A5	46 · 55	46 · 55	64 · 70 · 80	64 · 70 · 80	80 · 92 · 110	92 · 110 · 130	122 · 130 · 150	146 · 150 · 190	182 · 200 · 250 · 265
	A6	M4 x P0.7	M4 x P0.7	M5 x P0.8	M5 x P0.8	M5 x P0.8	M6 x P1.0	M8 x P1.25	M10 x P1.5	M10 x P1.5
<b>B</b>	B1	132	137	149 · 157	165 · 173	(191) · 203	260	313 · 334	399	479.5
	B2	67	62	74 · 82	75 · 83	(81) · 93	120	143 · 164	189	239.5
	B3(B3')	65	75(74)	75(74)	90	110	140	170	210	240
	B4	52	60	60	72	88	110	134	170	190
	B5	26	30	30	36	44	55	67	85	95
	B6	26	26	33.5 · 41.5	33.5 · 41.5	(33.5) · 45.5	59	67 · 83	85	116.5
	B7	5	5	5	6	(6) · 10	9	10 · 11	10	13.5
	B8	62	73	73	88	106	135	164	205	228
	B9	M5 x P0.8	M6 x P1.0	M6 x P1.0	M6 x P1.0	M8 x P1.25	M10 x P1.5	M12 x P1.75	M16 x P2.0	M16 x P2.0
<b>C</b>	C1	102	128	128	151	182	222	262	323	370
	C2	40	48	48	57	70	85	100	123	144
	C3	62	80	80	94	112	137	162	200	226
	C4	2	2	2	2	2	2	2	2	2
	C5	2.5	2.5	2.5	5	5	5	5	5	5
	C6	15	25	25	25	30	40	50	65	70
	C7	20	30	30	35	40	50	60	75	80
<b>D</b>	D1	14	16	16	18	22	32	40	50	55
	D2	5	5	5	6	6	10	12	14	16
	D3	16	18	18	20.5	24.5	35	43	53.5	59
	D4	M5 x P0.8	M5 x P0.8	M5 x P0.8	M5 x P0.8	M5 x P0.8	M10 x P1.5	M12 x P1.75	M12 x P1.75	M16 x P2.0
Weight		1.9	3.6	3.4	4.8	8.5	14.2	24	52	

# ST-DS series

RATIO : 1.2.3.4.5 ( 1-Stage)

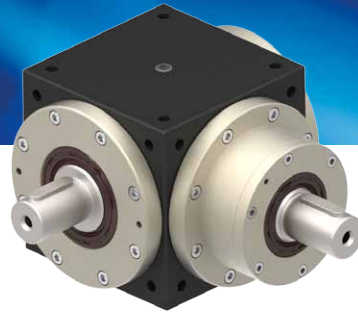

Single Input Shaft - Single Output Shaft

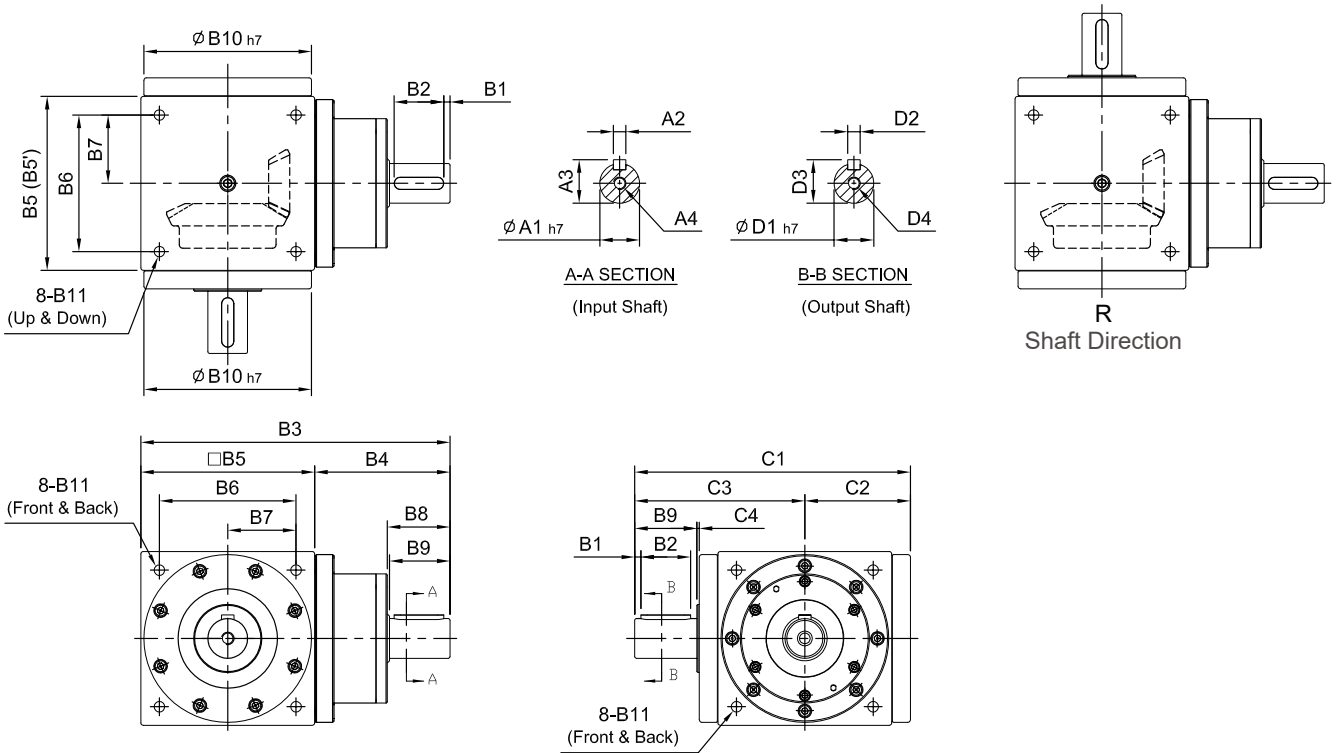

unit: mm

Code	Model	65	65 (1:1)	75	90	110	140	170	210	240	
	<b>A</b>	A1	14		16	18	22	32	40	50	55
	A2	5		5	6	6	10	12	14	16	
	A3	16		18	20.5	24.5	35	43	53.5	59	
	A4	M5 x P0.8		M5 x P0.8	M8 x P1.25	M8 x P1.25	M10 x P1.5	M12 x P1.75	M12 x P1.75	M16 x P2.0	
<b>B</b>	B1	2.5		2.5	5	5	5	5	5	5	
	B2	15		25	25	30	40	50	65	70	
	B3	127.5		143	168.5	207	250	300	375	430	
	B4	62.5		68	78.5	97	110	130	165	190	
	B5(B5')	65		75(74)	90	110	140	170	210	240	
	B6	52		60	72	88	110	134	170	190	
	B7	26		30	36	44	55	67	85	95	
	B8	22		32	38	43	53.5	64	77	82	
	B9	20		30	35	40	40	50	60	75	80
	B10	62	64	73	88	106	135	164	205	228	
	B11	M5 x P0.8		M6 x P1.0	M6 x P1.0	M8 x P1.25	M10 x P1.5	M12 x P1.75	M16 x P2.0	M16 x P2.0	
<b>C</b>	C1	102	107	128	151	182	222	262	323	370	
	C2	40	42.5	48	57	70	85	100	123	144	
	C3	62	64.5	80	94	112	137	162	200	226	
	C4	2		2	2	2	2	2	2	2	
<b>D</b>	D1	14		16	18	22	32	40	50	55	
	D2	5		5	6	6	10	12	14	16	
	D3	16		18	20.5	24.5	35	43	53.5	59	
	D4	M5 x P0.8		M5 x P0.8	M5 x P0.8	M5 x P0.8	M10 x P1.5	M12 x P1.75	M12 x P1.75	M16 x P2.0	
Weight		2.1		2.8	4.9	8.59	15.5	25	53		

# ST-YS series

RATIO : 1.2.3.4.5 ( 1-Stage)

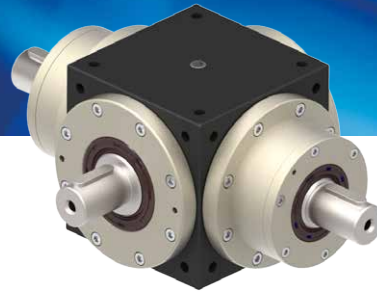

Double Input Shaft - Single Output Shaft

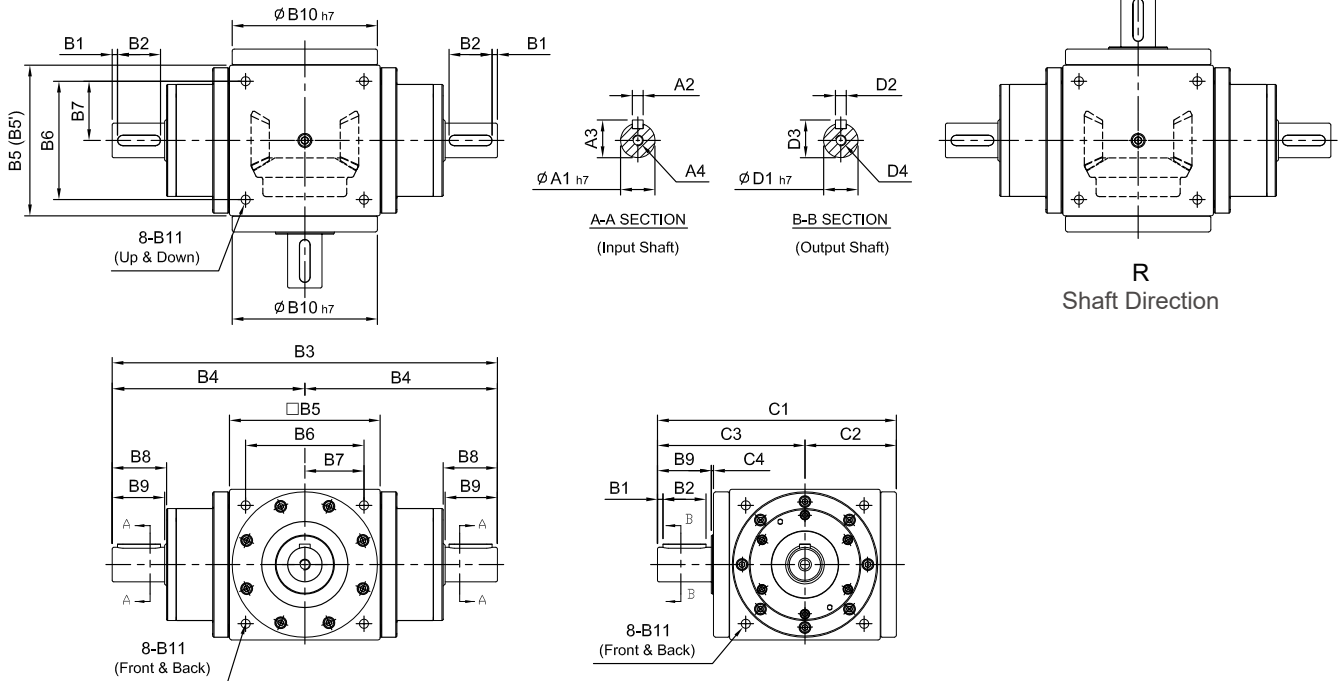

unit: mm

	Model Code	65	65 (1:1)	75	90	110	140	170	210	240
		<b>A</b>	A1	14	16	18	22	32	40	50
	A2	5	5	6	6	10	12	14	16	
	A3	16	18	20.5	24.5	35	43	53.5	59	
	A4	M5 x P0.8	M5 x P0.8	M8 x P1.25	M8 x P1.25	M10 x P1.5	M12 x P1.75	M12 x P1.75	M16 x P2.0	
<b>B</b>	B1	2.5	2.5	5	5	5	5	5	5	
	B2	15	25	25	30	40	50	65	70	
	B3	190	210	247	304	360	430	540	620	
	B4	95	105	123.5	152	180	215	270	310	
	B5(B5')	65	75(74)	90	110	140	170	210	240	
	B6	52	60	72	88	110	134	170	190	
	B7	26	30	36	44	55	67	85	95	
	B8	22	32	38	43	53.5	64	77	82	
	B9	20	30	35	40	50	60	75	80	
	B10	62	64	73	88	106	135	164	205	228
	B11	M5 x P0.8	M6 x P1.0	M6 x P1.0	M8 x P1.25	M10 x P1.5	M12 x P1.75	M16 x P2.0	M16 x P2.0	
<b>C</b>	C1	102	107	128	151	182	222	262	323	370
	C2	40	42.5	48	57	70	85	100	123	144
	C3	62	64.5	80	94	112	137	162	200	226
	C4	2	2	2	2	2	2	2	2	2
<b>D</b>	D1	14	16	18	22	32	40	50	55	
	D2	5	5	6	6	10	12	14	16	
	D3	16	18	20.5	24.5	35	43	53.5	59	
	D4	M5 x P0.8	M5 x P0.8	M5 x P0.8	M5 x P0.8	M10 x P1.5	M12 x P1.75	M12 x P1.75	M16 x P2.0	
<b>Weight</b>		2.85	3.6	6.2	11.5	18	28	57		



# ST-FV series

RATIO : 1.2.3.4.5 ( 1-Stage)

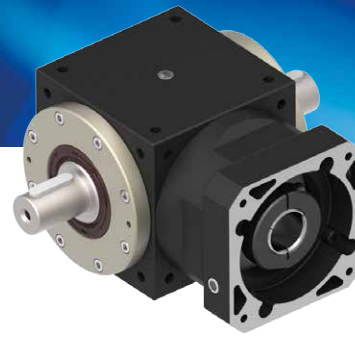

Input Flange - Double Output Shaft

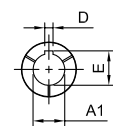
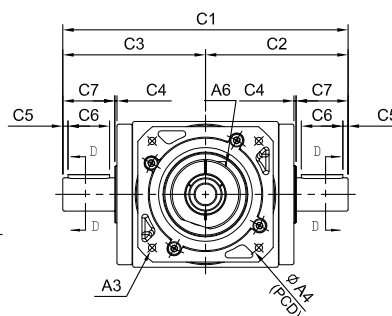
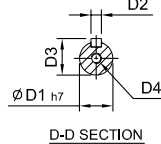
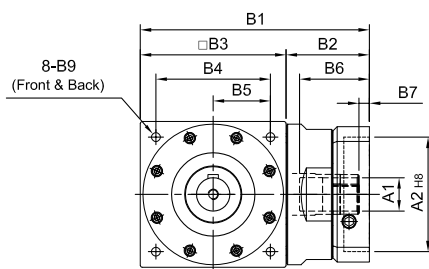
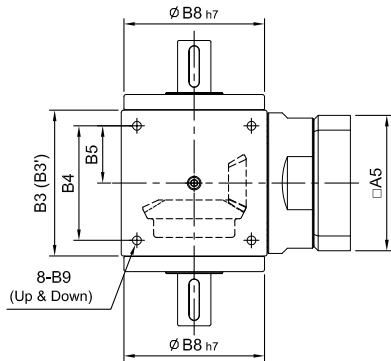

(170#)

$\varnothing A1$	D	E
$\varnothing 35$	10	38.3
$\varnothing 38$	10	41.3
$\varnothing 42$	12	45.3
$\varnothing 48$	14	51.8
$\varnothing 55$	16	59.3
$\varnothing 60$	18	64.4

unit: mm

	Model Code	65	65 (1:1)	75	90	110	140	170	210	240
		<b>A</b>	A1	9 · 11 · 14		14 · 19	16 · 19 · 22 · 24	19 · 22 · 24	24 · 28 · 32 · 35	35 · 38
	A2	50 · 60 · 70		50 · 60 · 70	70 · 80 · 95 · 110	70 · 80 · 95 · 110	95 · 110 · 130	110 · 130 · 180	114.3 · 180 · 230	114.3 · 230 · 250
	A3	M4 · M5 · M6		M4 · M5 · M6	M5 · M6 · M8	M5 · M6 · M8	M6 · M8 · M10	M8 · M10 · M120	M10 · M12 · M16	M12 · M16
	A4	70 · 75 · 90		70 · 75 · 90	90 · 100 · 115 · 145	90 · 100 · 115 · 145	115 · 145 · 165	145 · 165 · 200	200 · 215 · 265	200 · 265 · 300
	A5	64 · 70 · 80		64 · 70 · 80	92 · 110 · 130	92 · 110 · 130	122 · 130 · 150	146 · 150 · 190	182 · 200 · 250	222 · 250 · 265
	A6	M5 x P0.8		M5 x P0.8	M6 x P1.0	M6 x P1.0	M8 x P1.25	M10 x P1.5	M10 x P1.5	M10 x P1.5
<b>B</b>	B1	110		115 · 122	148 · 162	177 · 191	224 · 238	274	357 · 359	394.5 · 421.5 · 424.5
	B2	45		40	58 · 72	67 · 81	84 · 98	104	147	154.5 · 181.5 · 184.5
	B3(B3')	65		75(74)	90	110	140	170	210	240
	B4	52		60	72	88	110	134	170	190
	B5	26		30	36	44	55	67	85	95
	B6	36		36 · 43	51 · 65.5	51 · 65.5	68 · 81	84.5	117	115 · 142 · 145
	B7	7		7 · 13	9 · 23.5	9 · 23.5	9 · 10	9.5	14 · 16	12.5 · 15.5
	B8	62	64	73	88	106	135	164	205	228
	B9	M5 x P0.8		M6 x P1.0	M6 x P1.0	M8 x P1.25	M10 x P1.5	M12 x P1.75	M16 x P2.0	M16 x P2.0
<b>C</b>	C1	124	129	160	188	224	274	324	400	452
	C2	62	64.5	80	94	112	137	162	200	226
	C3	62	64.5	80	94	112	137	162	200	226
	C4	2		2	2	2	2	2	2	2
	C5	2.5		2.5	5	5	5	5	5	5
	C6	15		25	25	30	40	50	65	70
	C7	20		30	35	40	50	60	75	80
<b>D</b>	D1	14		16	18	22	32	40	50	55
	D2	5		5	6	6	10	12	14	16
	D3	16		18	20.5	24.5	35	43	53.5	59
	D4	M5 x P0.8		M5 x P0.8	M5 x P0.8	M5 x P0.8	M10 x P1.5	M12 x P1.75	M12 x P1.75	M16 x P2.0
Weight		1.7		2.4	4.3	7.1	14.9	24.5	46	

# ST-RV series

RATIO : 10.15.20.25.30.40.50 ( 2-Stage)

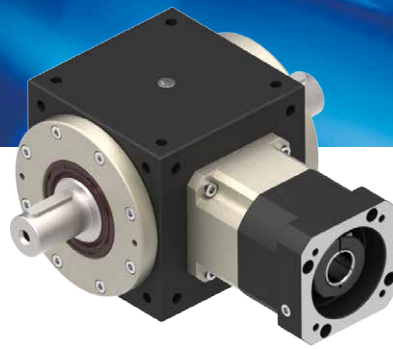

Fitted with Planetary Reducer - Double Output Shaft

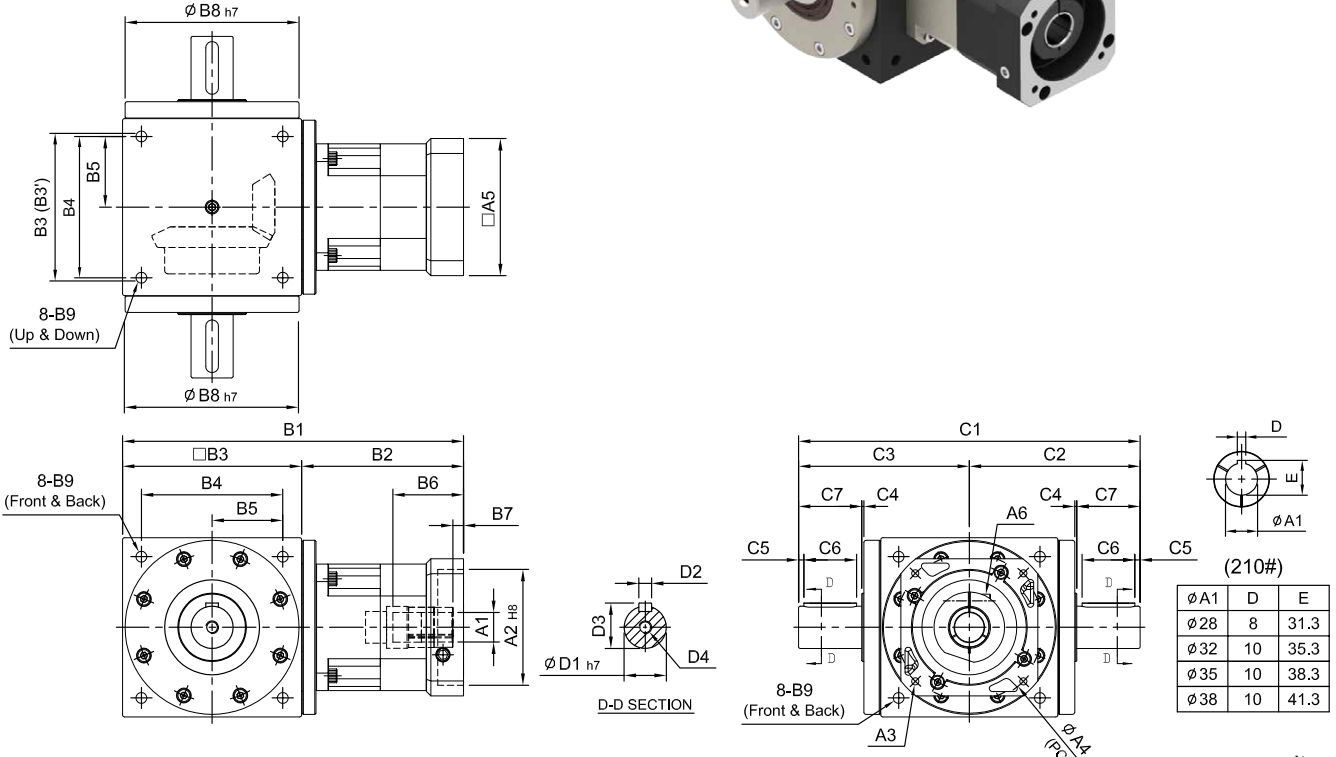

unit: mm

Model Code	65	75	90	110	140	170	210	240		
<b>A</b>	A1	8 · 9 · 11	8 · 9 · 11	11 · 14 · 16 · 19	11 · 14 · 16 · 19	(14) · 16 · 19	16 · 19 · 22 · 24	22 · 24 · 28 · 32 · 35	28 · 32 · 35 · 38	35 · 38 · 42 · 48 · 55
	A2	30 · 40 · 50	30 · 40 · 50	50 · 60 · 70	50 · 60 · 70	50 · 70 · 80 · 95	70 · 80 · 95 · 110	95 · 110 · 130	110 · 130 · 180	114.3 · 180 · 230 · 250
	A3	M3 · M4 · M5	M3 · M4 · M5	M4 · M5 · M6	M4 · M5 · M6	M5 · M6	M5 · M6 · M8	M6 · M8 · M10	M8 · M10 · M12	M10 · M12 · M16
	A4	46 · 60 · 63	46 · 60 · 63	70 · 75 · 90	70 · 75 · 90	70 · 90 · 100 · 115	90 · 100 · 115 · 145	115 · 145 · 165	145 · 165 · 200	200 · 215 · 265 · 300
	A5	46 · 55	46 · 55	64 · 70 · 80	64 · 70 · 80	80 · 92 · 110	92 · 110 · 130	122 · 130 · 150	146 · 150 · 190	182 · 200 · 250 · 265
	A6	M4 x P0.7	M4 x P0.7	M5 x P0.8	M5 x P0.8	M5 x P0.8	M6 x P1.0	M8 x P1.25	M10 x P1.5	M10 x P1.5
<b>B</b>	B1	132	137	149 · 157	165 · 173	(191) · 203	260	313 · 334	399	479.5
	B2	67	62	74 · 82	75 · 83	(81) · 93	120	143 · 164	189	239.5
	B3(B3')	65	75(74)	75(74)	90	110	140	170	210	240
	B4	52	60	60	72	88	110	134	170	190
	B5	26	30	30	36	44	55	67	85	95
	B6	26	26	33.5 · 41.5	33.5 · 41.5	(33.5) · 45.5	59	67 · 83	85	116.5
B7	5	5	5	6	(6) · 10	9	10 · 11	10	13.5	
B8	62	73	73	88	106	135	164	205	228	
B9	M5 x P0.8	M6 x P1.0	M6 x P1.0	M6 x P1.0	M8 x P1.25	M10 x P1.5	M12 x P1.75	M16 x P2.0	M16 x P2.0	
<b>C</b>	C1	124	160	160	188	224	274	324	400	452
	C2	62	80	80	94	112	137	162	200	226
	C3	62	80	80	94	112	137	162	200	226
	C4	2	2	2	2	2	2	2	2	2
	C5	2.5	2.5	2.5	5	5	5	5	5	5
	C6	15	25	25	25	30	40	50	65	70
C7	20	30	30	35	40	50	60	75	80	
<b>D</b>	D1	14	16	16	18	22	32	40	50	55
	D2	5	5	5	6	6	10	12	14	16
	D3	16	18	18	20.5	24.5	35	43	53.5	59
	D4	M5 x P0.8	M5 x P0.8	M5 x P0.8	M5 x P0.8	M5 x P0.8	M10 x P1.5	M12 x P1.75	M12 x P1.75	M16 x P2.0
Weight	1.9	3.6	3.4	4.8	8.5	14.2	24	52		

# ST-DV series

RATIO : 1.2.3.4.5 ( 1-Stage)

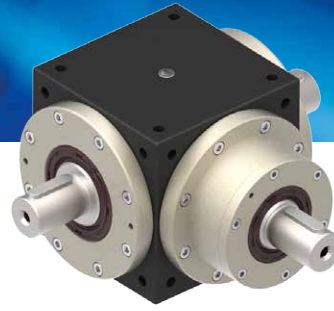

Single Input Shaft - Double Output Shaft

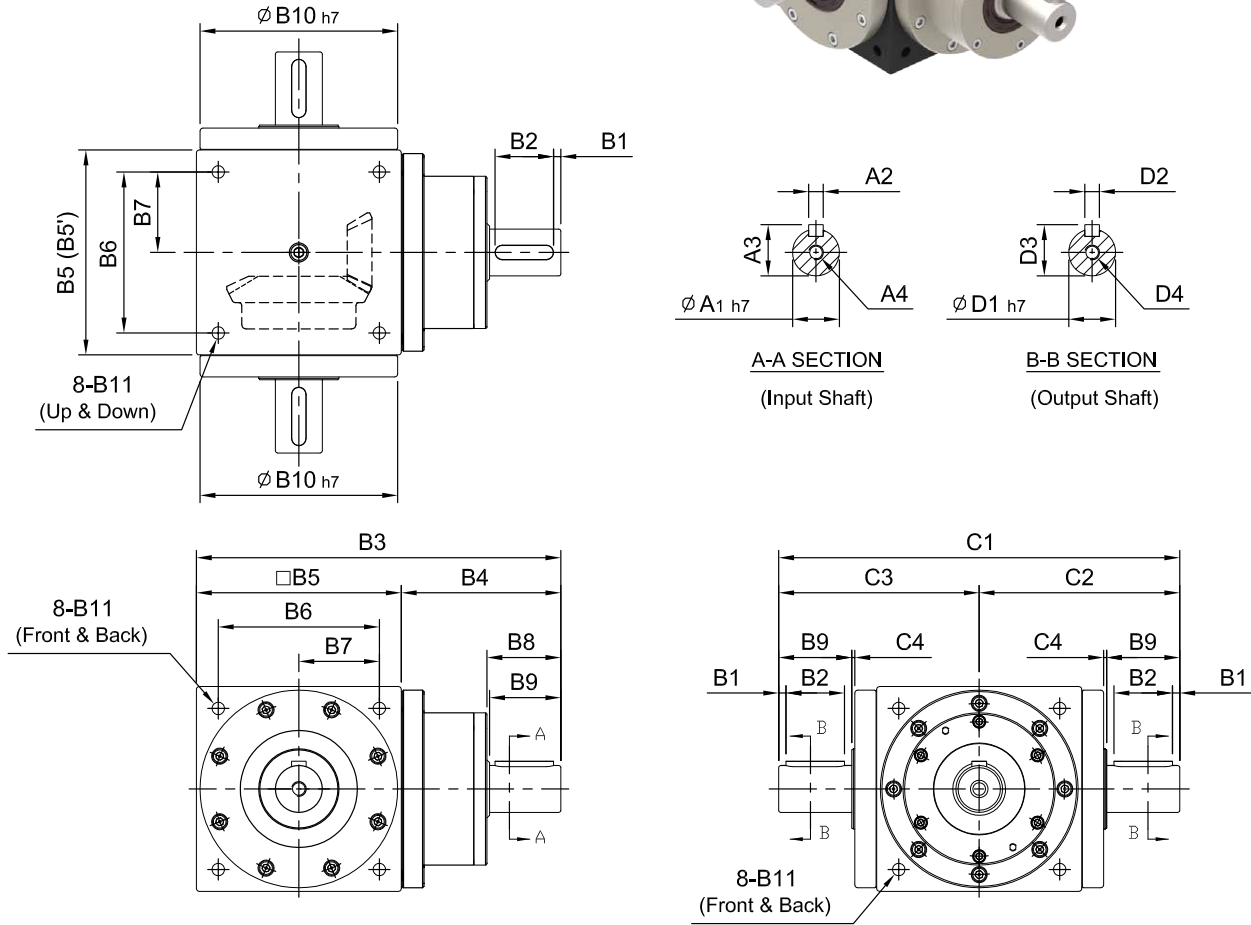

unit: mm

Model Code	65		65 (1:1)		75		90		110		140		170		210		240	
	<b>A</b>	A1	14	16	18	22	32	40	50	55	A2	5	5	6	6	10	12	14
	A3	16	18	20.5	24.5	35	43	53.5	59	A4	M5 x P0.8	M5 x P0.8	M8 x P1.25	M8 x P1.25	M10 x P1.5	M12 x P1.75	M12 x P1.75	M16 x P2.0
<b>B</b>	B1	2.5	2.5	5	5	5	5	5	5	B2	15	25	25	30	40	50	65	70
	B3	127.5	143	168.5	207	250	300	375	430	B4	62.5	68	78.5	97	110	130	165	190
	B5(B5')	65	75(74)	90	110	140	170	210	240	B5(B5')	65	75(74)	90	110	140	170	210	240
	B6	52	60	72	88	110	134	170	190	B6	52	60	72	88	110	134	170	190
	B7	26	30	36	44	55	67	85	95	B7	26	30	36	44	55	67	85	95
	B8	22	32	38	43	53.5	64	77	82	B8	22	32	38	43	53.5	64	77	82
	B9	20	30	35	40	50	60	75	80	B9	20	30	35	40	50	60	75	80
	B10	62	64	73	88	106	135	164	228	B10	62	64	73	88	106	135	164	228
	B11	M5 x P0.8	M6 x P1.0	M6 x P1.0	M8 x P1.25	M10 x P1.5	M12 x P1.75	M16 x P2.0	M16 x P2.0	B11	M5 x P0.8	M6 x P1.0	M6 x P1.0	M8 x P1.25	M10 x P1.5	M12 x P1.75	M16 x P2.0	M16 x P2.0
	<b>C</b>	C1	124	129	160	188	224	274	324	400	C1	124	129	160	188	224	274	324
C2		62	64.5	80	94	112	137	162	200	C2	62	64.5	80	94	112	137	162	200
C3		62	64.5	80	94	112	137	162	200	C3	62	64.5	80	94	112	137	162	200
C4		2	2	2	2	2	2	2	2	C4	2	2	2	2	2	2	2	2
<b>D</b>	D1	14	16	18	22	32	40	50	55	D1	14	16	18	22	32	40	50	55
	D2	5	5	6	6	10	12	14	16	D2	5	5	6	6	10	12	14	16
	D3	16	18	20.5	24.5	35	43	53.5	59	D3	16	18	20.5	24.5	35	43	53.5	59
	D4	M5 x P0.8	M5 x P0.8	M5 x P0.8	M5 x P0.8	M10 x P1.5	M12 x P1.75	M12 x P1.75	M16 x P2.0	D4	M5 x P0.8	M5 x P0.8	M5 x P0.8	M5 x P0.8	M10 x P1.5	M12 x P1.75	M12 x P1.75	M16 x P2.0
<b>Weight</b>		2.1	2.8	4.9	8.59	15.5	25	53										

# ST-YV series

RATIO : 1.2.3.4.5 ( 1-Stage)

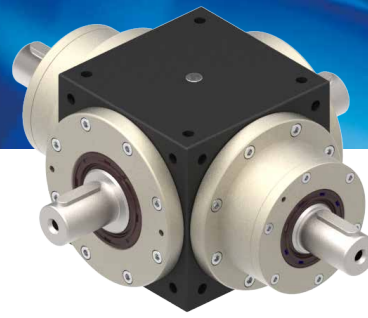

Double Input Shaft - Double Output Shaft

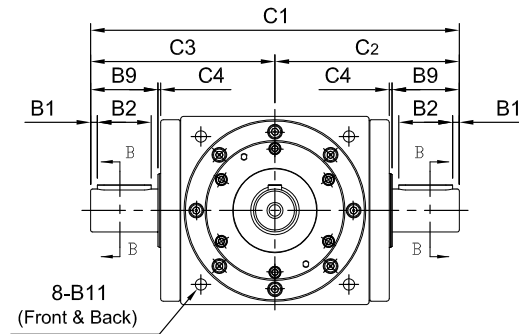
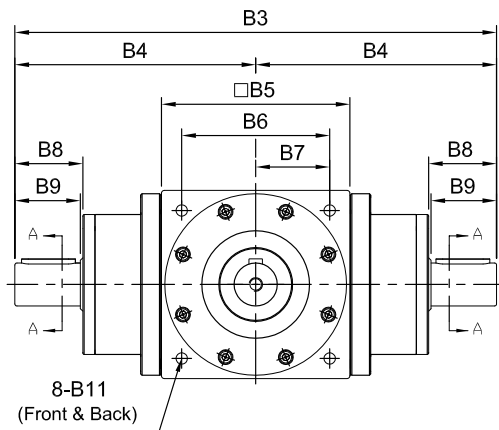
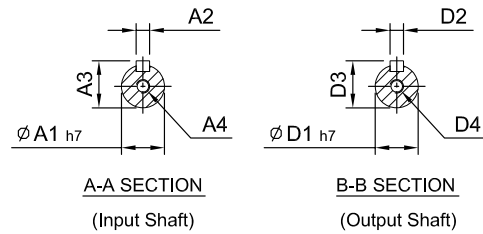
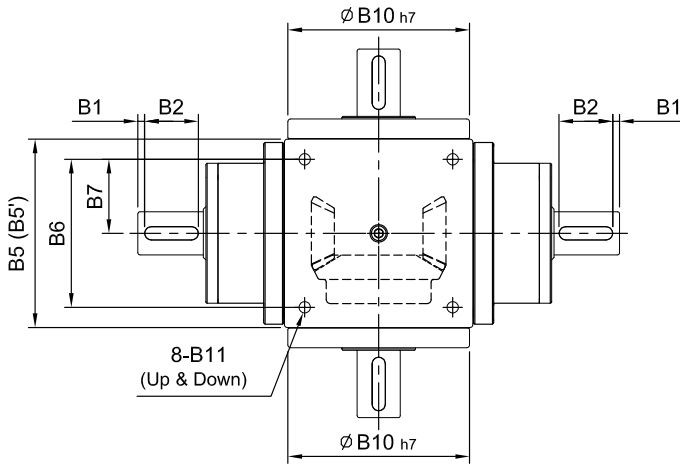

unit: mm

Model Code	65	65 (1:1)	75	90	110	140	170	210	240
	<b>A</b>	A1	14	16	18	22	32	40	50
	A2	5	5	6	6	10	12	14	16
	A3	16	18	20.5	24.5	35	43	53.5	59
	A4	M5 x P0.8	M5 x P0.8	M8 x P1.25	M8 x P1.25	M10 x P1.5	M12 x P1.75	M12 x P1.75	M16 x P2.0
<b>B</b>	B1	2.5	2.5	5	5	5	5	5	5
	B2	15	25	25	30	40	50	65	70
	B3	190	210	247	304	360	430	540	620
	B4	95	105	123.5	152	180	215	270	310
	B5(B5')	65	75(74)	90	110	140	170	210	240
	B6	52	60	72	88	110	134	170	190
	B7	26	30	36	44	55	67	85	95
	B8	22	32	38	43	53.5	64	77	82
	B9	20	30	35	40	50	60	75	80
	B10	62	64	73	88	106	135	164	205
	B11	M5 x P0.8	M6 x P1.0	M6 x P1.0	M8 x P1.25	M10 x P1.5	M12 x P1.75	M16 x P2.0	M16 x P2.0
<b>C</b>	C1	124	129	160	188	224	274	400	452
	C2	62	64.5	80	94	112	137	200	226
	C3	62	64.5	80	94	112	137	200	226
	C4	2	2	2	2	2	2	2	2
<b>D</b>	D1	14	16	18	22	32	40	50	55
	D2	5	5	6	6	10	12	14	16
	D3	16	18	20.5	24.5	35	43	53.5	59
	D4	M5 x P0.8	M5 x P0.8	M5 x P0.8	M5 x P0.8	M10 x P1.5	M12 x P1.75	M12 x P1.75	M16 x P2.0
<b>Weight</b>		2.85	3.6	6.2	11.5	18	28	57	

# ST-FP series

RATIO : 2.3.4.5 ( 1-Stage)

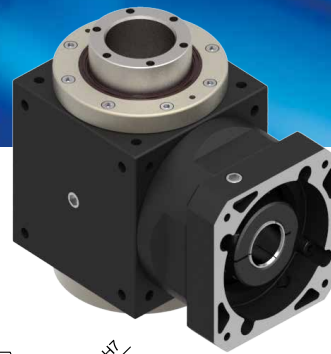

Input Flange - Ball Screw

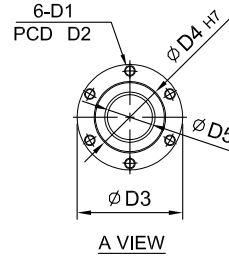
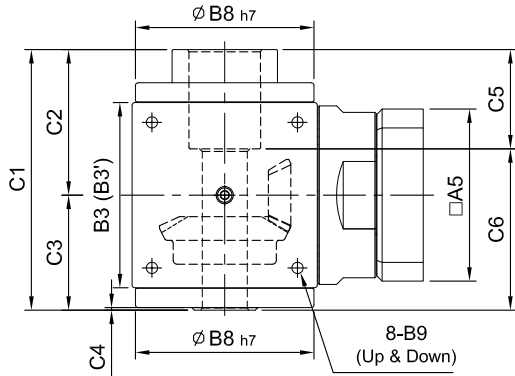

R  
Shaft Direction

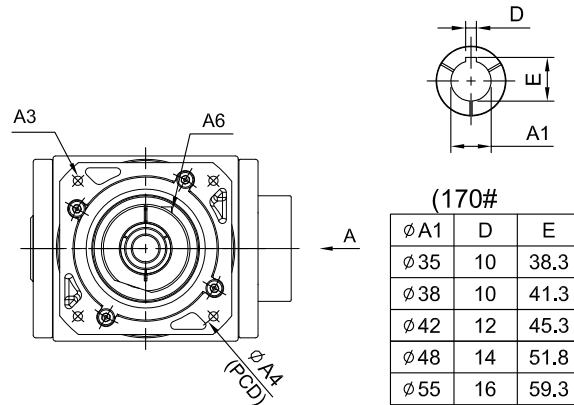
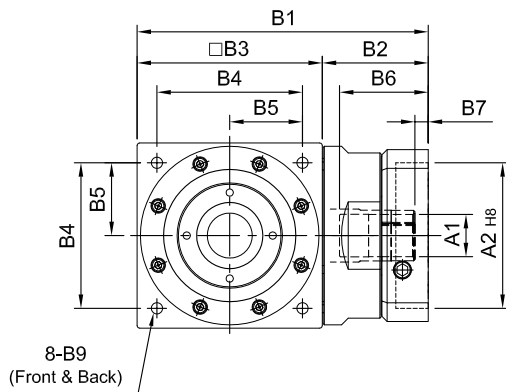

(170#)

Ø A1	D	E
Ø 35	10	38.3
Ø 38	10	41.3
Ø 42	12	45.3
Ø 48	14	51.8
Ø 55	16	59.3

unit: mm

Model Code	75	90	110	140	170	210	
<b>A</b>	A1	14 · 19	16 · 19 · 22 · 24	19 · 22 · 24	24 · 28 · 32 · 35	35 · 38	35 · 38 · 42 · 48 · 55
	A2	50 · 60 · 70	70 · 80 · 95 · 110	70 · 80 · 95 · 110	95 · 110 · 130	110 · 130 · 180	114.3 · 180 · 230
	A3	M4 · M5 · M6	M5 · M6 · M8	M5 · M6 · M8	M6 · M8 · M10	M8 · M10 · M120	M10 · M12 · M16
	A4	70 · 75 · 90	90 · 100 · 115 · 145	90 · 100 · 115 · 145	115 · 145 · 165	145 · 165 · 200	200 · 215 · 265
	A5	64 · 70 · 80	92 · 110 · 130	92 · 110 · 130	122 · 130 · 150	146 · 150 · 190	182 · 200 · 250
	A6	M5 x P0.8	M6 x P1.0	M6 x P1.0	M8 x P1.25	M10 x P1.5	M10 x P1.5
<b>B</b>	B1	115 · 122	148 · 162	177 · 191	224 · 238	274	357 · 359
	B2	40	58 · 72	67 · 81	84 · 98	104	147
	B3(B3')	75(74)	90	110	140	170	210
	B4	60	72	88	110	134	170
	B5	30	36	44	55	67	85
	B6	36 · 43	51 · 65.5	51 · 65.5	68 · 81	84.5	117
	B7	7 · 13	9 · 23.5	9 · 23.5	9 · 10	9.5	14 · 16
	B8	73	88	106	135	164	205
B9	M6 x P1.0	M6 x P1.0	M8 x P1.25	M10 x P1.5	M12 x P1.75	M16 x P2.0	
<b>C</b>	C1	106	127	156	197	223	267
	C2	57	68	84	109	121	142
	C3	49	59	72	88	102	125
	C4	1.25	2	2	2	2.25	2.25
	C5	33	44	55	75	72	82
	C6	73	83	101	122	153	185
<b>D</b>	D1	M4 x P0.7	M5 x P0.8	M5 x P0.8	M8 x P1.25	M10 x P1.5	M10 x P1.5
	D2	36	40	45	70	77	84
	D3	41.7	46.7	57.7	79.7	89.7	99.7
	D4	26	30	36	54	58	64
	D5	15	18	22	34	38	42
Weight	2.4	4.3	7.1	14.9	24.5	46	

# ST-RP series

RATIO : 10.15.20.25.30.40.50 ( 2-Stage)



Fitted with Planetary Reducer - Ball Screw

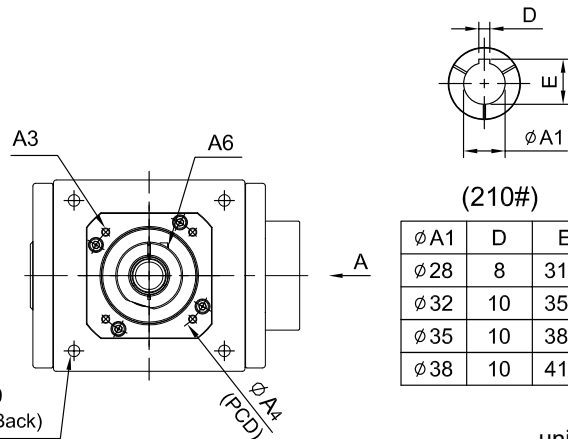
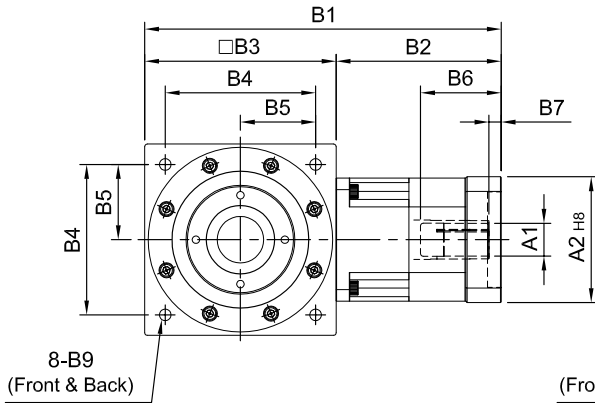
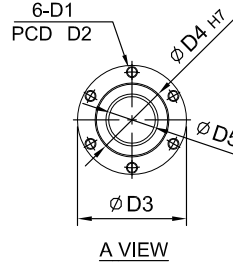
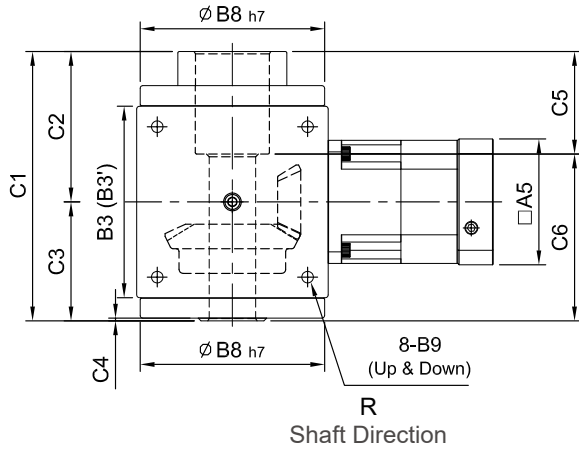

unit: mm

Model Code	75		90		110		140		170		210	
	A1	8 · 9 · 11	11 · 14 · 16 · 19	11 · 14 · 16 · 19	(14) · 16 · 19	16 · 19 · 22 · 24	22 · 24 · 28 · 32 · 35	28 · 32 · 35 · 38				
A2	30 · 40 · 50	50 · 60 · 70	50 · 60 · 70	50 · 70 · 80 · 95	70 · 80 · 95 · 110	95 · 110 · 130	110 · 130 · 180					
A3	M3 · M4 · M5	M4 · M5 · M6	M4 · M5 · M6	M5 · M6	M5 · M6 · M8	M6 · M8 · M10	M8 · M10 · M12					
A4	46 · 60 · 63	70 · 75 · 90	70 · 75 · 90	70 · 90 · 100 · 115	90 · 100 · 115 · 145	115 · 145 · 165	145 · 165 · 200					
A5	46 · 55	64 · 70 · 80	64 · 70 · 80	80 · 92 · 110	92 · 110 · 130	122 · 130 · 150	146 · 150 · 190					
A6	M4 x P0.7	M5 x P0.8	M5 x P0.8	M5 x P0.8	M6 x P1.0	M8 x P1.25	M10 x P1.5					
B1	137	149 · 157	165 · 173	(191) · 203	260	313 · 334	399					
B2	62	74 · 82	75 · 83	(81) · 93	120	143 · 164	189					
B3(B3')	75(74)	75(74)	90	110	140	170	210					
B4	60	60	72	88	110	134	170					
B5	30	30	36	44	55	67	85					
B6	26	33.5 · 41.5	33.5 · 41.5	(33.5) · 45.5	59	67 · 83	85					
B7	5	5	6	(6) · 10	9	10 · 11	10					
B8	73	73	88	106	135	164	205					
B9	M6 x P1.0	M6 x P1.0	M6 x P1.0	M8 x P1.25	M10 x P1.5	M12 x P1.75	M16 x P2.0					
C1	106	106	127	156	197	223	267					
C2	57	57	68	84	109	121	142					
C3	49	49	59	72	88	102	125					
C4	1.25	1.25	2	2	2	2.25	2.25					
C5	33	33	44	55	75	72	82					
C6	73	73	83	101	122	153	185					
D1	M4 x P0.7	M4 x P0.7	M5 x P0.8	M5 x P0.8	M8 x P1.25	M10 x P1.5	M10 x P1.5					
D2	36	36	40	45	70	77	84					
D3	41.7	41.7	46.7	57.7	79.7	89.7	99.7					
D4	26	26	30	36	54	58	64					
D5	15	15	18	22	34	38	42					
Weight	3.6	3.6	4.8	8.5	14.2	24	52					

# ST-DP series

RATIO : 2.3.4.5 ( 1-Stage)



Single Input Shaft - Ball Screw

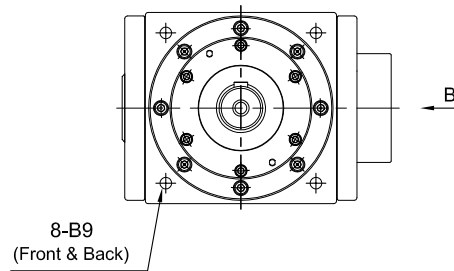
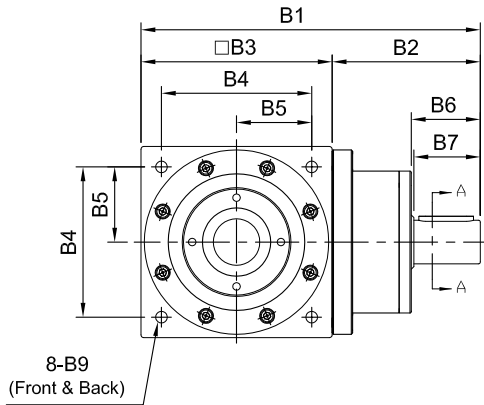
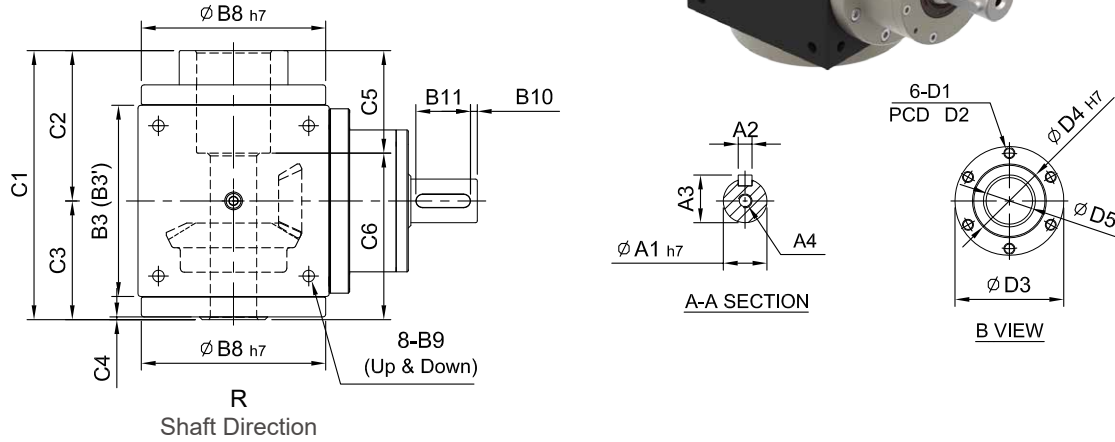

unit: mm

Model Code	75	90	110	140	170	210	
<b>A</b>	A1	16	18	22	32	40	50
	A2	5	6	6	10	12	14
	A3	18	20.5	24.5	35	43	53.5
	A4	M5 x P0.8	M8 x P1.25	M8 x P1.25	M10 x P1.5	M12 x P1.75	M12 x P1.75
<b>B</b>	B1	143	169	207	250	300	375
	B2	68	79	97	110	130	165
	B3(B3')	75(74)	90	110	140	170	210
	B4	60	72	88	110	134	170
	B5	30	36	44	55	67	85
	B6	32	38	43	53.5	64	77
	B7	30	35	40	50	60	75
	B8	73	88	106	135	164	205
B9	M6 x P1.0	M6 x P1.0	M8 x P1.25	M10 x P1.5	M12 x P1.75	M16 x P2.0	
B10	2.5	5	5	5	5	5	
B11	25	25	30	40	50	65	
<b>C</b>	C1	106	127	156	197	223	267
	C2	57	68	84	109	121	142
	C3	49	59	72	88	102	125
	C4	1.25	2	2	2	2.25	2.25
	C5	33	44	55	75	72	82
	C6	73	83	101	122	153	185
<b>D</b>	D1	M4 x P0.7	M5 x P0.8	M5 x P0.8	M8 x P1.25	M10 x P1.5	M10 x P1.5
	D2	36	40	45	70	77	84
	D3	41.7	46.7	57.7	79.7	89.7	99.7
	D4	26	30	36	54	58	64
	D5	15	18	22	34	38	42
Weight	2.8	4.9	8.59	15.5	25	53	

# ST-YP series

RATIO : 2.3.4.5 ( 1-Stage)



Double Input Shaft - Ball Screw

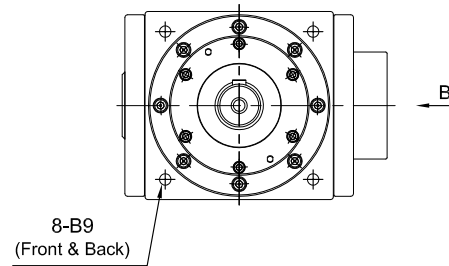
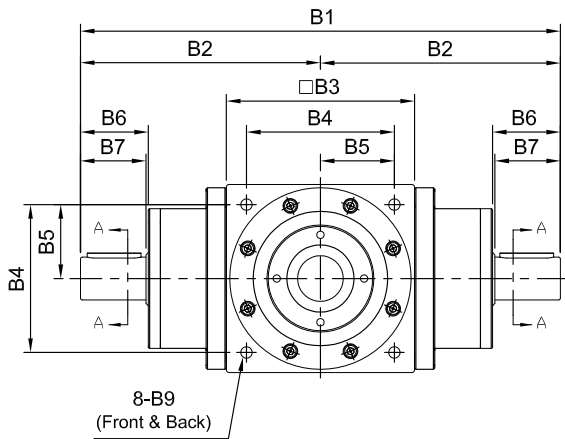
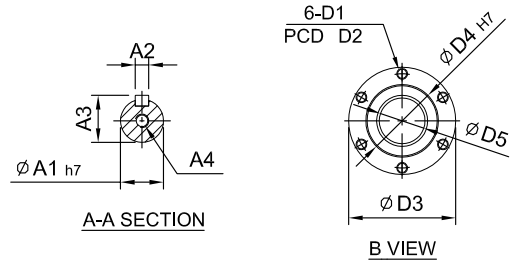
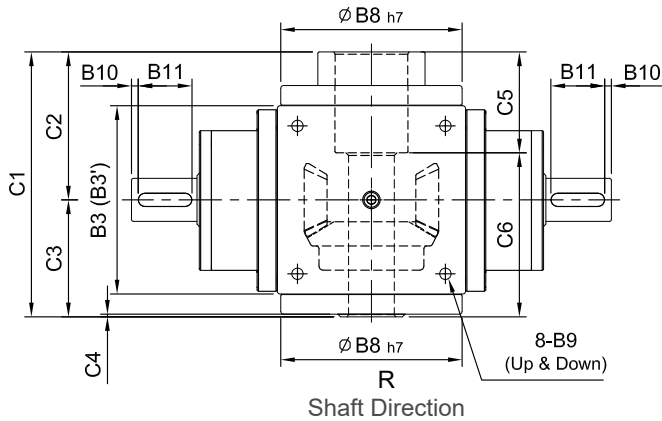

unit: mm

Model Code	75	90	110	140	170	210	
<b>A</b>	A1	16	18	22	32	40	50
	A2	5	6	6	10	12	14
	A3	18	20.5	24.5	35	43	53.5
	A4	M5 x P0.8	M8 x P1.25	M8 x P1.25	M10 x P1.5	M12 x P1.75	M12 x P1.75
<b>B</b>	B1	210	247	304	360	430	540
	B2	105	123.5	152	180	215	270
	B3(B3')	75(74)	90	110	140	170	210
	B4	60	72	88	110	134	170
	B5	30	36	44	55	67	85
	B6	32	38	43	53.5	64	77
	B7	30	35	40	50	60	75
	B8	73	88	106	135	164	205
	B9	M6 x P1.0	M6 x P1.0	M8 x P1.25	M10 x P1.5	M12 x P1.75	M16 x P2.0
	B10	2.5	5	5	5	5	5
B11	25	25	30	40	50	65	
<b>C</b>	C1	106	127	156	197	223	267
	C2	57	68	84	109	121	142
	C3	49	59	72	88	102	125
	C4	1.25	2	2	2	2.25	2.25
	C5	33	44	55	75	72	82
	C6	73	83	101	122	153	185
<b>D</b>	D1	M4 x P0.7	M5 x P0.8	M5 x P0.8	M8 x P1.25	M10 x P1.5	M10 x P1.5
	D2	36	40	45	70	77	84
	D3	41.7	46.7	57.7	79.7	89.7	99.7
	D4	26	30	36	54	58	64
	D5	15	18	22	34	38	42
Weight	3.6	6.2	11.5	18	28	57	