



DSF
DSG

Indication of Model Numbers

DSF	14	P	C	100	MOTOR
Type	Model	Style	Input Style	Ratio	Motor Type
DSF DSG	14 17 20 25 32 40	P: Component Type A: Unit Type MC: Motor Flange Type S: Input Shaft Type	C: Input Collet K: Input Keyway ----- Input style is optional for style P, A.	1/50 1/80 1/100 1/120 ----- Model 14# Ratio 1/50 1/80 1/100	

DSF □ -PC- □
DSG □ -PC- □

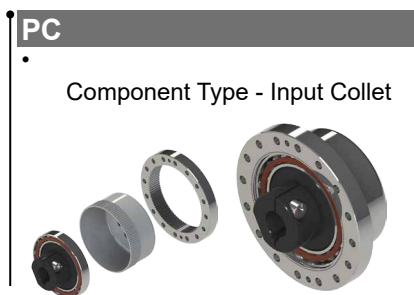

DSF □ -AC- □
DSG □ -AC- □



DSF □ -MC- □
DSG □ -MC- □

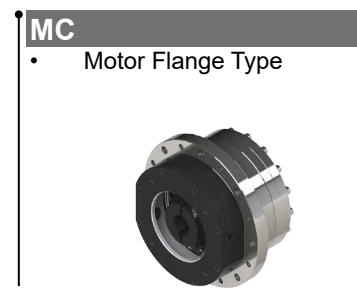

DSF □ -PK- □
DSG □ -PK- □

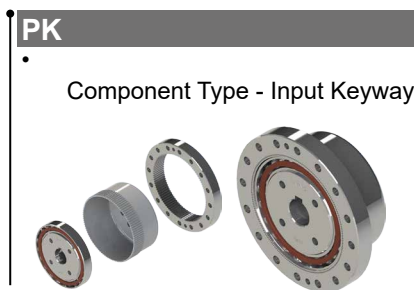

DSF □ -AK- □
DSG □ -AK- □



DSF □ -S- □
DSG □ -S- □



DSF / DSG Characteristic of DSF / DSG

Model No.	Unit	Ratio	14	17	20	25	32	40
Nominal Output Torque	Nm	50	7	20	30	45	90	140
		80	9	27	40	72	138	209
		100	9	29	47	77	160	261
		120	-	29	47	77	160	298
Max. Output Torque	Nm	50	9	32	40	64	127	200
		80	13	33	55	99	195	288
		100	13	48	58	123	253	377
		120	-	48	58	123	253	457
Emergency Stop Starting Torque	Nm	50	21	42	66	112	225	350
		80	27	53	86	157	316	452
		100	32	67	96	180	346	494
		120	-	67	102	191	367	537
Starting Torque	cNm	50	4	6	8	15	32	55
		80	3	4	5	9	20	35
		100	2.5	3.5	4	8	18	32
		120	-	3	4	7	15	28
Output Starting Torque	Nm	50	1.5	2.6	4.1	8.2	17	29
		80	1.6	2.7	4.2	8.4	18	30
		100	1.7	2.8	4.3	8.6	19	32
		120	-	2.9	4.5	8.8	20	34
No-load Running Torque	cNm	50	4	5	7	12	28	48
		80	3	4	6	10	20	30
		100	2	3	5	8	18	26
		120	-	3	4	7	14	25
Nominal Input Speed	rpm	50~120	2,000	2,000	2,000	2,000	2,000	2,000
Max. Input Speed	rpm	50~120	6,000	6,000	5,000	5,000	5,000	4,000
Reducer Inertia	lx10-4kgm ²	50~120	0.04	0.08	0.2	0.4	1.7	4.5
Efficiency	%	50	70	73	73	73	75	75
		80	68	70	72	72	74	74
		100	64	66	70	70	72	72
		120	-	64	68	68	70	70
Operating Temperature	°C	50~120	Environment -10°C ~ +70°C / Max. Working Temperature 90°C					
Lubrication		50~120	Synthetic Grease No.2					
Noise Level	dB	50~120	52	54	56	58	60	62



MODEL : DSF-PC、DSG-PC

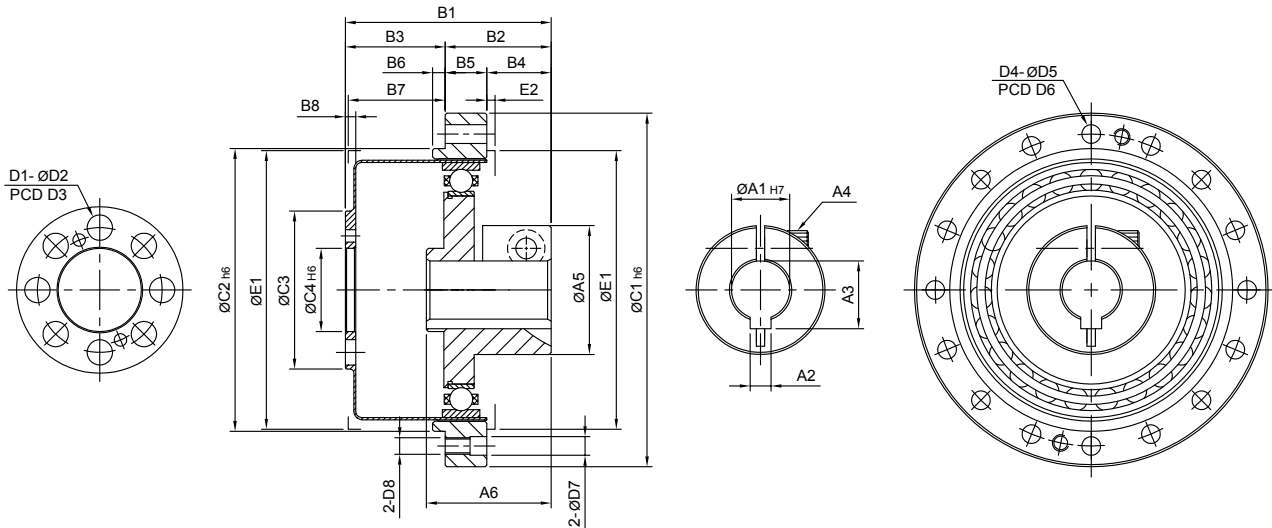

Code \ Model	14	17	20	25	32	40
A1	8	8	8、11、14	14	14、19	19
A2	3	3	3、4、5	5	5、6	6
A3	9.4	9.4	9.4、12.7、16.3	16.3	16.3、21.8	21.8
A4	M4xP0.7	M4xP0.7	M4xP0.7、M5xP0.8	M5xP0.8	M5xP0.8	M5xP0.8
A5	23.5	23.5	23.5、26、31	31	34、38	38
A6	22	23	25.5、27.5	30	32.5	36.5
B1	36	39	42.5、44.5	49.5	58	67.5
B2	18.5	19	21、23	25.5	30	33.5
B3	17.5	20	21.5	24	28	34
B4	12.5	12.5	13.5、15.5	15.5	16	16.5
B5	6	6.5	7.5	10	14	17
B6	2	2.5	3	3	3	4
B7	16.5	19	20.5	23	27	33
B8	2.4	3	3	3	3.2	4
C1	50	60	70	85	110	135
C2	38	48	54	68	90	110
C3	23	26	31	38	50	64
C4	11	10	14	20	26	32
D1	6	6	8	8	8	8
D2	4.1	5.1	5.1	6.1	8.1	10.1
D3	17	19	24	30	40	50
D4	DSG	8	16	16	16	16
	DSF	6	12	12	12	12
D5	3.5	3.4	3.5	4.5	5.5	6.6
D6	44	54	62	75	100	120
D7	-	-	3.5	4.5	5.5	6.6
D8	M3xP0.5	M3xP0.5	M3xP0.5	M4xP0.7	M5xP0.8	M6xP1.0
E1	37	46	53	67	86	105
E2	1.5	1.5	2	2	2	3
O-Ring	d35x1.0t	d44x1.2t	d51.82x1.5t	d63.22x1.78t	d84.5x2.0t	d107.62x2.62t
Weight (g)	132	195	300	495	1,018	3,383

MODEL : DSF-PK、DSG-PK

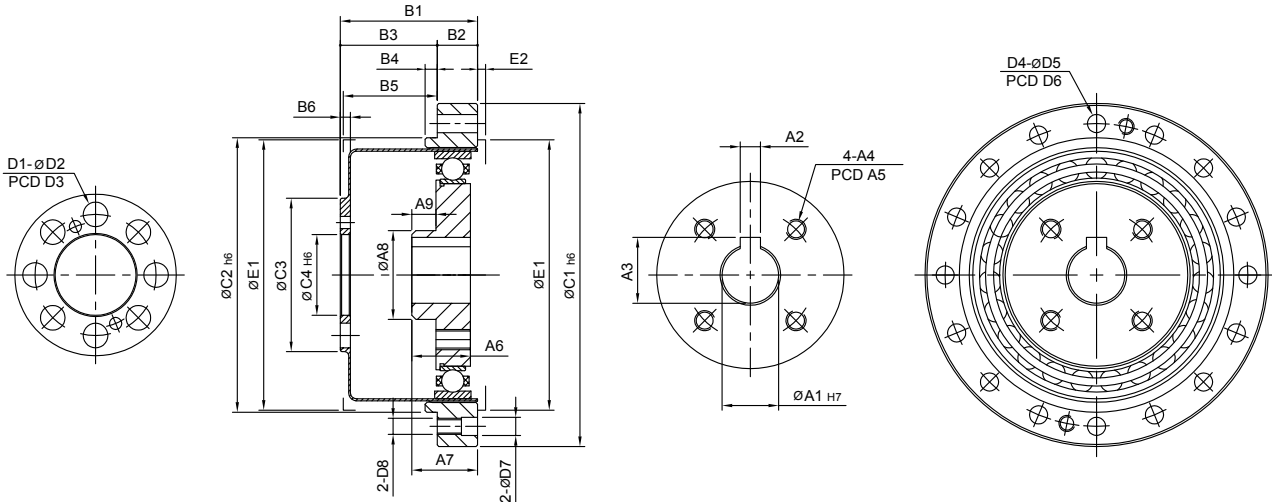

Code \ Model	14	17	20	25	32	40
A1	6、8	8	8、14	14	14、19	19、24
A2	2、3	3	3、5	5	5、6	6、8
A3	7、9.4	9.4	9.4、16.3	16.3	16.3、21.8	21.8、27.3
A4	2-M4xP0.7	2-M4xP0.7	M4xP0.7	M5xP0.8	M5xP0.8	M5xP0.8
A5	18	22	25	32	36	50
A6	10	12.5	13.5	14.5	16	20
A7	10.5	13	14	16.3	17.45	22
A8	14	16	21	24	30	36
A9	2.3	4.2	4.3	6	5	7
B1	23.5	26.5	29	34	42	51
B2	6	6.5	7.5	10	14	17
B3	17.5	20	21.5	24	28	34
B4	2	2.5	3	3	3	4
B5	16.5	19	20.5	23	27	33
B6	2.4	3	3	3	3.2	4
C1	50	60	70	85	110	135
C2	38	48	54	68	90	110
C3	23	26	31	38	50	64
C4	11	10	14	20	26	32
D1	6	6	8	8	8	8
D2	4.1	5.1	5.1	6.1	8.1	10.1
D3	17	19	24	30	40	50
D4	DSG	8	16	16	16	16
	DSF	6	12	12	12	12
D5	3.5	3.4	3.5	4.5	5.5	6.6
D6	44	54	62	75	100	120
D7	-	-	3.5	4.5	5.5	6.6
D8	M3xP0.5	M3xP0.5	M3xP0.5	M4xP0.7	M5xP0.8	M6xP1.0
E1	37	46	53	67	86	105
E2	1.5	1.5	2	2	2	3
O-Ring	d35x1.0t	d44x1.2t	d51.82x1.5t	d63.22x1.78t	d84.5x2.0t	d107.62x2.62t
Weight (g)	100	167	246	446	938	3,297

MODEL : DSF-AC 、 DSG-AC

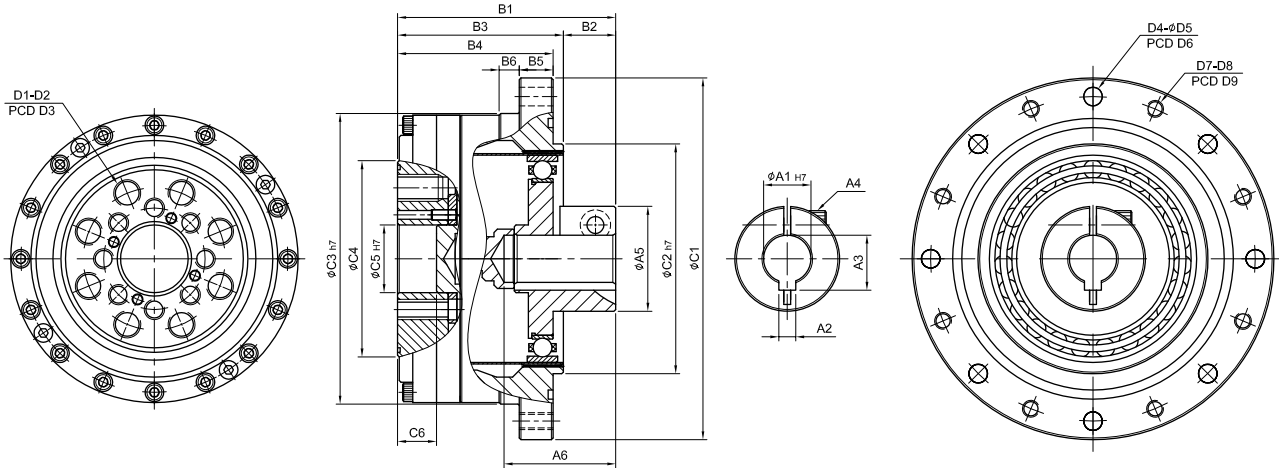

Code \ Model	14	17	20	25	32	40
A1	8	8	8、11、14	14	14、19	16、19
A2	3	3	3、4、5	5	5、6	6
A3	9.4	9.4	9.4、12.7、16.3	16.3	16.3、21.8	21.8
A4	M4xP0.7	M4xP0.7	M4xP0.7、M5xP0.8	M5xP0.8	M5xP0.8	M5xP0.8
A5	23.5	23.5	23.5、26.5、31	31	34、38	38
A6	23.5	24.5	27、29	33	38.5	46
B1	48.5	51.5	54.5、56.5	64.5	76	87
B2	12.5	12.5	13.5、15.5	15.5	16	16.5
B3	36	39	41	49	60	70.5
B4	34	37	38	46	57	66.5
B5	7	8	10	10	12	16
B6	4	5	6	6	5	5
C1	73	79	93	107	138	160
C2	38	48	56	67	90	110
C3	56	63	72	86	113	127
C4	31	38	45	58	78	90
C5	11	10	14	20	26	32
C6	9.4	9.5	9	12	15.2	5
D1	6	6	8	8	8	8
D2	M4xP0.7 deep12.5	M5xP0.8 deep12.5	M6xP1.0 deep12	M8xP1.25 deep15	M10xP1.5 deep18	M10xP1.5 deep19.5
D3	23	27	32	42	55	68
D4	DSG 8 DSF 6	8 6	8 6	10 8	12 12	10 8
D5	4.5	4.5	5.5	5.5	6.5	9
D6	65	71	82	96	125	144
D7	DSG 8 DSF 6	8 6	8 6	10 8	12 12	10 8
D8	M4xP0.7	M4xP0.7	M5xP0.8	M5xP0.8	M6xP1.0	M8xP1.25
D9	65	71	82	96	125	144
O-Ring	d49.5x2t	d55.5x2t	d66.5x2t	d79.5x2.0t	d104.5x2t	d124.5x2t
Output O-Ring	d29x0.6t	d35x0.6t	d43x1.5t	d55x1.5t	d72x1.5t	d85x1.5t
Weight (g)	555	733	1,039	1,629	3,463	5,174

MODEL : DSF-AK、DSG-AK

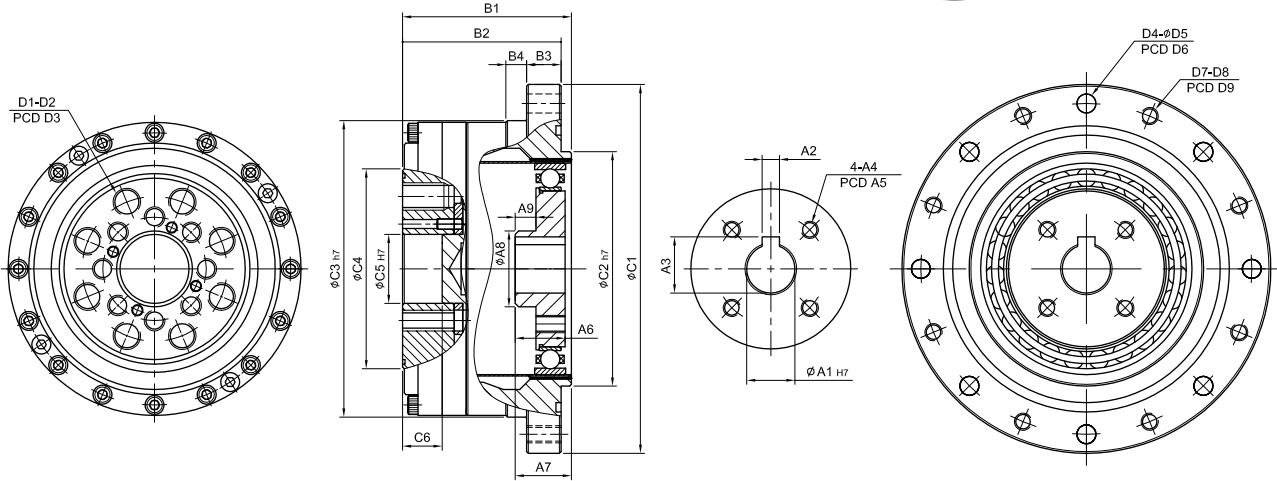

Code \ Model	14	17	20	25	32	40
A1	6、8	8	8、14	14	14、19	19、24
A2	2、3	3	3、5	5	5、6	6、8
A3	7、9.4	9.4	9.4、16.3	16.3	16.3、21.8	21.8、27.3
A4	2-M4xP0.7	2-M4xP0.7	M4xP0.7	M5xP0.8	M5xP0.8	M5xP0.8
A5	18	22	25	32	36	50
A6	10	12.5	13.5	14.5	16	20
A7	10.5	13	14	16.3	17.45	22
A8	14	16	21	24	30	36
A9	2.3	4.2	4.3	6	5	7
B1	36	39	41	49	60	70.5
B2	34	37	38	46	57	66.5
B3	7	8	10	10	12	16
B4	4	5	6	6	5	5
C1	73	79	93	107	138	160
C2	38	48	56	67	90	110
C3	56	63	72	86	113	127
C4	31	38	45	58	78	90
C5	11	10	14	20	26	32
C6	9.4	9.5	9	12	15.2	5
D1	6	6	8	8	8	8
D2	M4xP0.7 deep12.5	M5xP0.8 deep12.5	M6xP1.0 deep12	M8xP1.25 deep15	M10xP1.5 deep18	M10xP1.5 deep19.5
D3	23	27	32	42	55	68
D4	DSG 8 DSF 6	8 6	8 6	10 8	12 12	10 8
D5	4.5	4.5	5.5	5.5	6.5	9
D6	65	71	82	96	125	144
D7	DSG 8 DSF 6	8 6	8 6	10 8	12 12	10 8
D8	M4xP0.7	M4xP0.7	M5xP0.8	M5xP0.8	M6xP1.0	M8xP1.25
D9	65	71	82	96	125	144
O-Ring	d49.5x2t	d55.5x2t	d66.5x2t	d79.5x2.0t	d104.5x2t	d124.5x2t
Output O-Ring	d29x0.6t	d35x0.6t	d43x1.5t	d55x1.5t	d72x1.5t	d85x1.5t
Weight (g)	523	705	985	1,581	3,383	5,084

MODEL : DSF-MC 、 DSG-MC

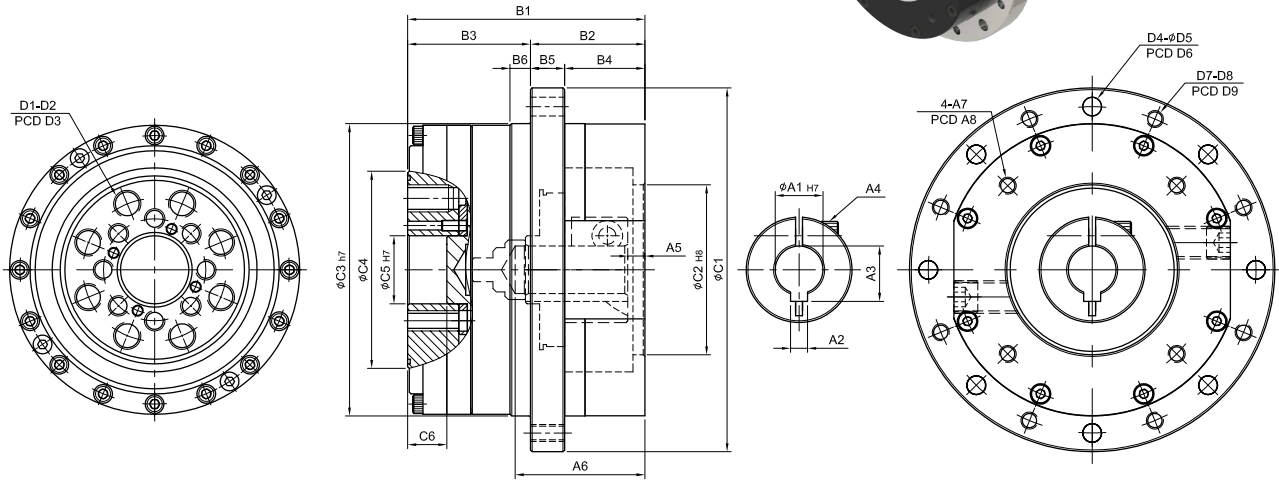

Code \ Model	14	17	20	25	32	40
A1	8	8	8、11、14	14	14、19	16、19
A2	3	3	3、4、5	5	5、6	5、6
A3	9.4	9.4	9.4、12.7、16.3	16.3	16.3、21.8	18.3、21.8
A4	M4xP0.7	M4xP0.7	M4xP0.7 M5xP0.8	M5xP0.8	M5xP0.8	M5xP0.8
A5	4	4	4、5	5	5	5
A6	27.5	28.5	31、34	38	43.5	51
A7	M3xP0.5 M4xP0.7	M3xP0.5 M4xP0.7	M4xP0.7 M5xP0.8	M5xP0.8	M4xP0.7、M5xP0.8 M6xP1.0	M5xP0.8 M6xP1.0
A8	45、46	45、46	46、63、70	70	65、70、90、100	70、90、98.43
B1	52.5	55.5	58.5、61.5	69.5	81	92
B2	25.5	26.5	30.5、33.5	33.5	36	41.5
B3	27	29	28	36	45	50.5
B4	18.5	18.5	20.5、23.5	23.5	24	25.5
B5	7	8	10	10	12	16
B6	4	5	6	6	5	5
C1	73	79	93	107	138	160
C2	30	30	30、40、50	50	36、50、70、80	50、70、73
C3	56	63	72	86	113	127
C4	31	38	45	58	78	90
C5	11	10	14	20	26	32
C6	9.4	9.5	9	12	15.2	5
D1	6	6	8	8	8	8
D2	M4xP0.7 deep12.5	M5xP0.8 deep12.5	M6xP1.0 deep12	M8xP1.25 deep15	M10xP1.5 deep18	M10xP1.5 deep19.5
D3	23	27	32	42	55	68
D4	DSG	8	8	10	12	10
	DSF	6	6	6	8	8
D5	4.5	4.5	5.5	5.5	6.5	9
D6	65	71	82	96	125	144
D7	DSG	8	8	10	12	10
	DSF	6	6	6	8	8
D8	M4xP0.7	M4xP0.7	M5xP0.8	M5xP0.8	M6xP1.0	M8xP1.25
D9	65	71	82	96	125	144
Output O-Ring	d29x0.6t	d35x0.6t	d43x1.5t	d55x1.5t	d72x1.5t	d85x1.5t
Weight (g)	633	836	1,155	1,831	3,881	5,673

MODEL : DSF-S 、DSG-S

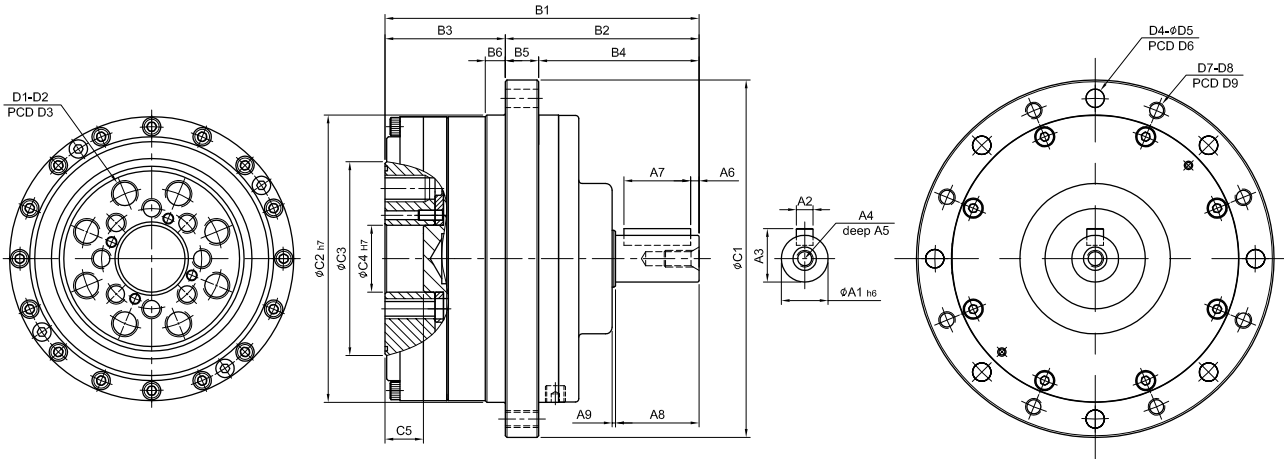

Code \ Model	14	17	20	25	32	40
A1	8	11	11	14	14	19
A2	3	4	4	5	5	6
A3	9.2	12.5	12.5	16	16	21.5
A4	M3xP0.5	M4xP0.7	M4xP0.7	M5xP0.8	M5xP0.8	M6xP1.0
A5	7	8	8	10	10	12
A6	1	1.5	2.5	2.5	2.5	2.5
A7	10	12	15	20	20	25
A8	12	16	20	25	25	30
A9	1	1	1	1	1	1
B1	63.5	70.5	78	94	113.5	129.5
B2	36.5	41.5	50	58	68.5	79
B3	27	29	28	36	45	50.5
B4	29.5	33.5	40	48	56.5	63
B5	7	8	10	10	12	16
B6	4	5	6	6	5	5
C1	73	79	93	107	138	160
C2	56	63	72	86	113	127
C3	31	38	45	58	78	90
C4	11	10	14	20	26	32
C5	9.4	9.5	9	12	15.2	5
D1	6	6	8	8	8	8
D2	M4xP0.7 deep12.5	M5xP0.8 deep12.5	M6xP1.0 deep12	M8xP1.25 deep15	M10xP1.5 deep18	M10xP1.5 deep19.5
D3	23	27	32	42	55	68
D4	DSG 8 DSF 6	8 6	8 6	10 8	12 12	10 8
D5	4.5	4.5	5.5	5.5	6.5	9
D6	65	71	82	96	125	144
D7	DSG 8 DSF 6	8 6	8 6	10 8	12 12	10 8
D8	M4xP0.7	M4xP0.7	M5xP0.8	M5xP0.8	M6xP1.0	M8xP1.25
D9	65	71	82	96	125	144
Output O-Ring	d29x0.6t	d35x0.6t	d43x1.5t	d55x1.5t	d72x1.5t	d85x1.5t
Weight (g)	620	818	1,125	1,842	3,972	5,882