

## 11.3 Type VC – Servo bevel gearboxes

Fitting dimensions of the servo-motor – gearbox size/flange no. (selection)

d [mm] less than or equal to	Gearbox size	Flange no.	L [mm]	LK [mm]	ZK [mm]
11	065	001	23	63	40
	065	002	23	63	40
	065	102	23	75	60
	065	202	23	90	60
14	065	103	30	75	60
	065	104	30	75	60
	065	201	30	90	60
	065	301	30	95	50
	065	401	30	100	80
	065	501	30	115	95
19	090	103	40	75	60
	090	201	40	90	60
	090	301	40	95	50
	090	401	40	100	80
	090	501	40	115	95
	090	601	40	130	95
	090	611	40	130	110
	090	701	40	145	110
24	090	802	40	165	110
	120	103	50	75	60
	120	201	50	90	60
	120	301	50	95	50
	120	401	50	100	80
	120	501	50	115	95
	120	601	50	130	95
	120	611	50	130	110
	120	701	50	145	110
	120	802	50	165	110
32	120	811	50	165	130
	140	403	60	100	80
	140	502	60	115	95
	140	601	60	130	95
	140	611	60	130	110
	140	616	60	130	110
	140	701	60	145	110
	140	802	60	165	110
	140	811	60	165	130
	140	902	60	215	130
	140	911	60	215	180
	160	403	60	100	80
	160	502	60	115	95
	160	601	60	130	95
	160	611	60	130	110
	160	616	60	130	110
	160	701	60	145	110
	160	802	60	165	110
	160	811	60	165	130
	160	902	60	215	130
	160	911	60	215	180
	200	614	60	130	110
200	616	60	130	110	
200	802	60	165	110	
200	811	60	165	130	
200	902	60	215	130	
200	913	60	215	180	
38	140	931	80	215	180
	160	931	80	215	180
	200	915	80	215	180

Table 11.3.14-1



Servo gearboxes  
(precision gearboxes)

500 07  
(SS)

# 11.3 Type VC – Servo bevel gearboxes

## 11.3.15 Features

Gear ratios:  $i = 1:1$  to  $6:1$   
 Maximum acceleration torques up to  $T_{2B} = 700 \text{ Nm}$   
 6 gearbox sizes with edge lengths of 065 to 200 mm  
 High efficiency  
 Minimized circumferential backlash (optional)  
 Bevel gearboxes suitable for fitting servo-motors  
 Zero-play three-piece claw coupling

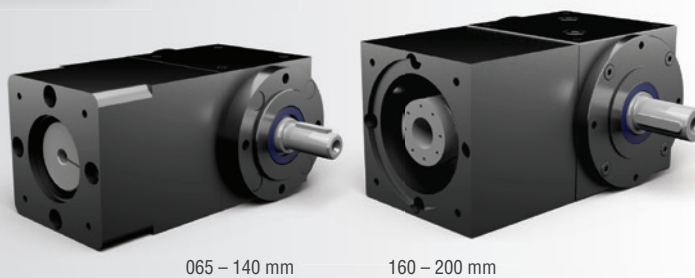

### 11.3.15.1 Models

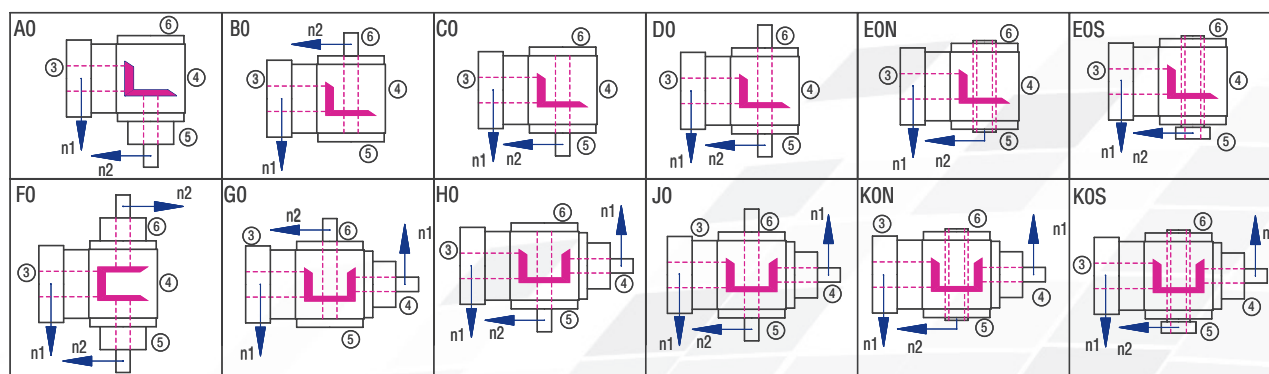

Figure 11.3.15-1; Models

### 11.3.15.2 Gearbox sides

The example shows the Model C0

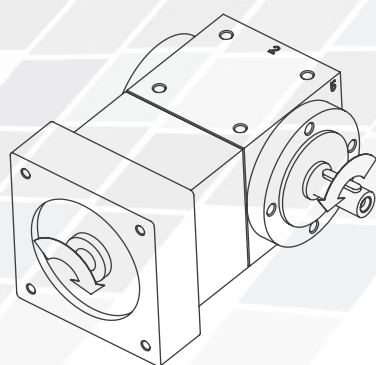

Figure 11.3.15-3; Gearbox sides

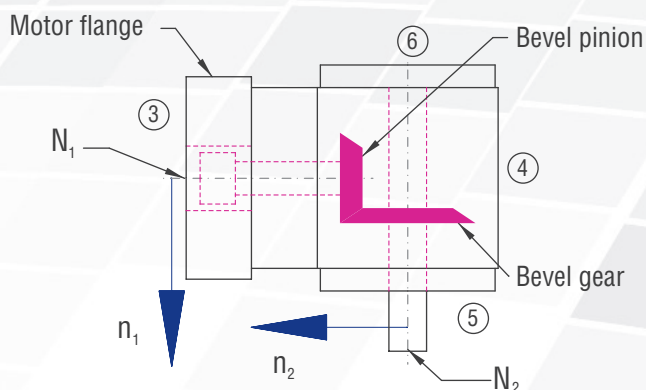

Figure 11.3.15-2; Gearbox sides

### 11.3.15.3 Order code

The order code reflects the customer specifications. Example:

Type	Size	Gear ratio	Model	Fixing side	Installation position	Speed $n_2$	Design
VC	065	2:1	C0-	1.	1-	1500	/KN
Description	Size; Table 11.3.15-1	Table 11.3.15-1	Figure 11.3.15-1, Models	Gearbox side on which fixing is made; Table 11.3.4-1	Side directed downwards; Figure 4.3.1-1 Gearbox sides	Slowly rotating shaft; Table 11.3.15-1	Clamping hub
V080-	/	14 x 30	No. 301				
Flange		Motor shaft $\varnothing$ x length	Flange no.				

### 11.3.15.4 Overview of performance data

Selection table: gearbox size; gear ratio; rotational speed

Depending on the diameter of the motor shaft, lower torques may be possible in the operating mode S5.

Operating mode S1		Gear ratio						
		1:1	1.5:1	2:1	3:1	4:1	5:1	6:1
Gearbox sizes		T <sub>2N</sub> [Nm]	T <sub>2N</sub> [Nm]	T <sub>2N</sub> [Nm]	T <sub>2N</sub> [Nm]	T <sub>2N</sub> [Nm]	T <sub>2N</sub> [Nm]	T <sub>2N</sub> [Nm]
065	4000	3.6	5.4	7.2	7.2			
	3000	4.8	7.2	9.6	9.6			
	2400	6	9	10	10			
	1500	8	10	10	10			
090	4000	8	12	17	21	21	21	21
	3000	11	17	23	23	23	23	23
	2400	14	21	24	24	25	25	25
	1500	17	25	27	27	27	27	27
120	4000		21	28	42	52	52	45
	3000	18	28	37	56	60	60	54
	2400	23	35	46	63	67	65	59
	1500	37	56	73	74	74	72	64
140	4000		34	45	68	85	90	85
	3000		45	60	90	103	100	95
	2400	37	56	75	113	111	105	102
	1500	60	90	120	130	120	115	108
160	4000				102	136	160	115
	3000		68	90	136	180	180	130
	2400	56	85	113	170	200	198	137
	1500	90	136	181	230	220	215	145
200	4000				177	235	275	190
	3000			157	235	314	300	210
	2400		147	196	294	393	340	225
	1500	157	236	314	472	455	380	240

Operating mode S2		Gear ratio						
		1:1	1.5:1	2:1	3:1	4:1	5:1	6:1
T <sub>2N</sub> [Nm]		8	10	10	8	0	0	0
T <sub>2B</sub> [Nm]		15	17	17	15	0	0	0
T <sub>2Not</sub>		23	25	25	20	0	0	0
N <sub>1max</sub>		4400	6000	6000	6000	0	0	0
T <sub>2N</sub> [Nm]		25	25	25	23	23	23	23
T <sub>2B</sub> [Nm]		40	37	36	36	36	36	31
T <sub>2Not</sub>		50	50	60	60	60	50	45
N <sub>1max</sub>		3200	4800	6000	6000	6000	6000	6000
T <sub>2N</sub> [Nm]		50	61	65	58	60	60	54
T <sub>2B</sub> [Nm]		70	105	98	95	87	92	71
T <sub>2Not</sub>		150	140	140	140	140	120	110
N <sub>1max</sub>		2400	3600	4800	6000	6000	6000	6000
T <sub>2N</sub> [Nm]		120	113	110	110	105	100	95
T <sub>2B</sub> [Nm]		180	200	190	177	162	143	122
T <sub>2Not</sub>		260	280	280	260	260	220	200
N <sub>1max</sub>		2100	3000	4200	5000	6000	6000	6000
T <sub>2N</sub> [Nm]		180	185	185	190	180	180	130
T <sub>2B</sub> [Nm]		350	330	320	280	270	270	200
T <sub>2Not</sub>		480	500	550	400	400	380	350
N <sub>1max</sub>		1800	2500	3200	4500	5000	6000	6000
T <sub>2N</sub> [Nm]		350	330	320	420	350	300	210
T <sub>2B</sub> [Nm]		700	690	600	630	550	505	315
T <sub>2Not</sub>		980	850	800	850	800	800	625
N <sub>1max</sub>		1500	2250	3000	4000	4500	5000	6000

Table 11.3.15-1

	Operating mode	On-period
S1	Continuous operation	10 greater than 60% of the cycle time or longer than 20 minutes
S5	Cyclic operation	less than 60% of the process procedure and less than 20 minutes

Servo gearboxes  
(precision gearboxes)

## 11.3.16 Type VC 065 – Servo bevel gearboxes

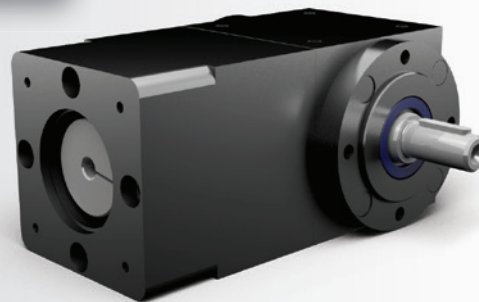

### Characteristics

Characteristic	Standard	Option
<b>Toothing</b>	Spiral-toothed, hardened bevel gears	See chapter 11.3.2
<b>Gear ratio</b>	1:1 to 3:1	
<b>Housing / Flanges</b>	Grey cast iron / aluminium	
<b>Threaded mounting holes</b>	On all housing surfaces without flange and on all flanges.	See chapter 11.3.4
<b>Shaft</b>	Material 1 C45, shaft ends greased Fit with ISO 6 tolerance with parallel keyway: according to DIN 6885 Sheet 1	See chapter 4.6.2
<b>Hollow shaft</b>	Material 1 C45, shafts greased Fit with ISO 7 tolerance with parallel keyway: according to DIN 6885 Sheet 1	See chapter 4.6.3
<b>Radial shaft seal ring</b>	NBR, form A	See chapter 4.8
<b>Ambient temperature</b>	-10°C to +90°C. The values of the performance tables are valid for +20°C	See chapter 4.9.3
<b>Circumferential backlash</b>	< 20 arcmin	See chapter 11.3.11
<b>Protection class</b>	IP 54	See chapter 4.5
<b>Corrosion protection</b>	Prime coat; layer thickness > 40 µm	See chapter 4.4.1
<b>Bearing life L10h</b>	more than 15,000h	See chapter 4.9.1
<b>Oil change intervals</b>	Not required if the oil temperature is kept < 90°C The lifetime of the bearings can be increased by the factor 1.5 if the oil is changed after the first 500 service hours and then every 5000 service hours.	See chapter 11.3.9
<b>Lubricants</b>	Synthetic lubricants	See chapter 11.3.9
<b>Motor flange</b>	Aluminium	See chapter 11.3.14
<b>Coupling</b>	Insertable, flexible claw coupling, suitable for servo-motors For smooth motor shafts                      clamping hub For smooth motor shafts                      tension ring hub For motor shafts with parallel key        clamping hub with groove	KN SN KNN See chapter 11.3.13

### Torques in operating mode S1

Gear ratio i [-]	1:1		1.5:1		2:1		3:1		4:1		5:1		6:1	
	T <sub>2N</sub> [Nm]	n <sub>2</sub> [rpm]	T <sub>2N</sub> [Nm]	n <sub>2</sub> [rpm]	T <sub>2N</sub> [Nm]	n <sub>2</sub> [rpm]	T <sub>2N</sub> [Nm]	n <sub>2</sub> [rpm]	T <sub>2N</sub> [Nm]	n <sub>2</sub> [rpm]	T <sub>2N</sub> [Nm]	n <sub>2</sub> [rpm]	T <sub>2N</sub> [Nm]	n <sub>2</sub> [rpm]
<b>4000</b>	3.6	4000	5.4	2667	7.2	2000	7.2	1333						
<b>3000</b>	4.8	3000	7.2	2000	9.6	1500	9.6	1000						
<b>2400</b>	6	2400	9	1600	10	1200	10	800						
<b>1500</b>	8	1500	10	1000	10	750	10	500						

## Torques in operating mode S5, dynamic operation

Gear ratio i [-]			1:1	1.5:1	2:1	3:1	4:1	5:1	6:1
T <sub>2N</sub> in S5 [Nm]			8	10	10	8			
n <sub>1max</sub> in S5 [rpm]			4400	6000	6000	6000			
Coupling size	Motor shaft d [mm]	Coupling type	1:1	1.5:1	2:1	3:1	4:1	5:1	6:1
K14	9	KN	T <sub>2B</sub> [Nm]	5.3	8.0	10.6	15.0		
			T <sub>2NOT</sub> [Nm]	7.0	10.5	14.0	20.0		
		KNN	T <sub>2B</sub> [Nm]	10.0	15.0	17.0	15.0		
			T <sub>2NOT</sub> [Nm]	22.0	25.0	25.0	20.0		
		SN	T <sub>2B</sub> [Nm]	10.0	15.0	17.0	15.0		
			T <sub>2NOT</sub> [Nm]	22.0	25.0	25.0	20.0		
	11	KN	T <sub>2B</sub> [Nm]	5.6	8.4	11.2	15.0		
			T <sub>2NOT</sub> [Nm]	9.0	13.5	18.0	20.0		
		KNN	T <sub>2B</sub> [Nm]	10.0	15.0	17.0	15.0		
			T <sub>2NOT</sub> [Nm]	23.0	25.0	25.0	20.0		
		SN	T <sub>2B</sub> [Nm]	10.0	15.0	17.0	15.0		
			T <sub>2NOT</sub> [Nm]	23.0	25.0	25.0	20.0		
	14	KN	T <sub>2B</sub> [Nm]	6.1	9.1	12.2	15.0		
			T <sub>2NOT</sub> [Nm]	13.0	19.5	25.0	20.0		
		KNN	T <sub>2B</sub> [Nm]	10.0	15.0	17.0	15.0		
			T <sub>2NOT</sub> [Nm]	23.0	25.0	25.0	20.0		
		SN	T <sub>2B</sub> [Nm]	10.0	15.0	17.0	15.0		
			T <sub>2NOT</sub> [Nm]	23.0	25.0	25.0	20.0		
	16	KN	T <sub>2B</sub> [Nm]	6.5	9.8	13.0	15.0		
			T <sub>2NOT</sub> [Nm]	15.0	22.5	25.0	20.0		
		KNN	T <sub>2B</sub> [Nm]	10.0	15.0	17.0	15.0		
			T <sub>2NOT</sub> [Nm]	23.0	25.0	25.0	20.0		
		SN	T <sub>2B</sub> [Nm]	10.0	15.0	17.0	15.0		
			T <sub>2NOT</sub> [Nm]	23.0	25.0	25.0	20.0		

## Permissible radial force F<sub>r2</sub> and axial force F<sub>a2</sub> on shaft N<sub>2</sub>

n <sub>2</sub> [rpm]	3000		1000		500		250		100		50	
	T <sub>2</sub> [Nm]	F <sub>r</sub> [N]	F <sub>a</sub> [N]	F <sub>r</sub> [N]	F <sub>a</sub> [N]	F <sub>r</sub> [N]	F <sub>a</sub> [N]	F <sub>r</sub> [N]	F <sub>a</sub> [N]	F <sub>r</sub> [N]	F <sub>a</sub> [N]	
< 12	300	150	400	200	500	250	650	325	750	375	900	450
> 12	250	125	330	165	420	210	540	270	630	315	750	375

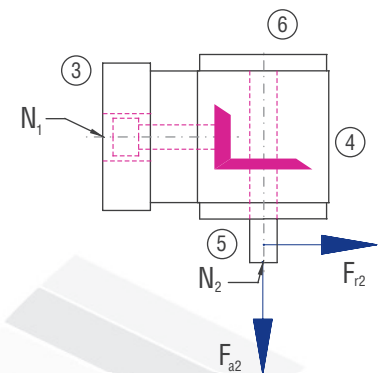

## Gearbox inertia moments/mass

Inertia moment J<sub>1</sub> related to the fast-rotating shaft (N<sub>1</sub>)

Model	Inertia moment [kgcm <sup>2</sup> ]						
	1:1	1.5:1	2:1	3:1	4:1	5:1	6:1
AO	0.4740	0.2110	0.1830	0.1830			
BO	0.4680	0.3190	0.2590	0.1940			
CO	0.4680	0.3190	0.2590	0.1940			
DO	0.4780	0.3230	0.2620	0.2380			
EON	0.5200	0.3710	0.3110	0.2320			
EOS	0.6460	0.4968	0.4370	0.3570			
FO	0.7080	0.2600	0.2040	0.1910			
GO	0.7540	0.4730	0.3950	0.3200			
HO	0.7540	0.4730	0.3950	0.3200			

## Inertia moments Coupling J [kgcm<sup>2</sup>]

K14	d [mm]	KN	KNN	SN
		J [kgcm <sup>2</sup> ]	J [kgcm <sup>2</sup> ]	J [kgcm <sup>2</sup> ]
6	6	0.029	0.000	0.069
9	9	0.029	0.029	0.069
11	11	0.029	0.029	0.067
14	14	0.028	0.028	0.656
16	16	0.000	0.000	0.000

The mass of the gearbox may deviate depending on the flange size and the gear ratio.

# 11.3.16 Type VC 065 – Servo bevel gearboxes

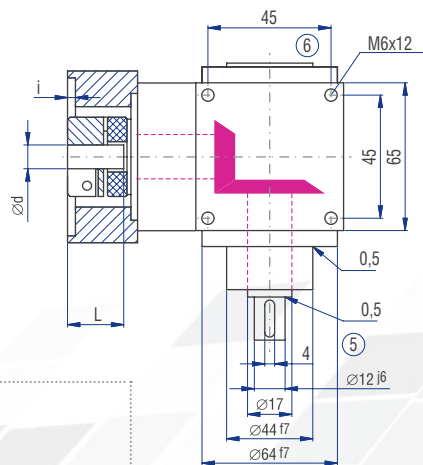
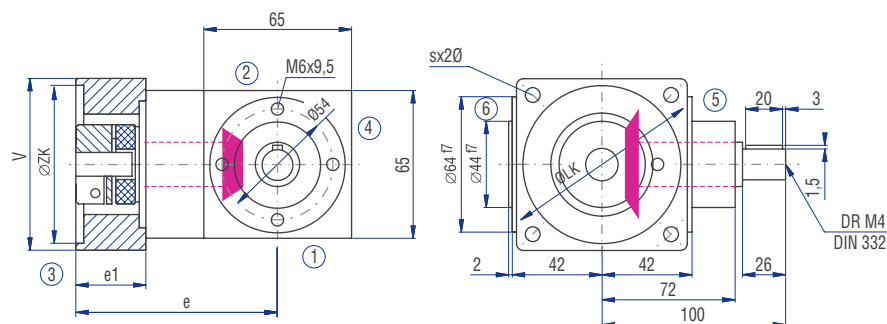
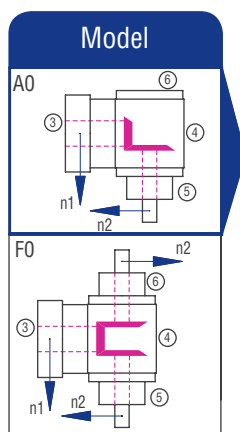

## Motor mounting dimensions

Flange no.	V [mm]	ZK [mm]	Thread	LK [mm]	Shaft dxL [mm]	i [mm]	e [mm]	e1 [mm]
001	65	40	M4	63	11*23	3	104.5	30
002	65	40	M5	63	11*23	3	104.5	30
102	70	60	M5	75	11*23	3	101.0	26.5
103	70	60	M6	90	14*30	3	119.5	45
104	70	60	M5	75	14*30	3	119.5	45
201	80	60	M5	75	14*30	4	119.5	45
202	80	60	M5	90	11*23	4	101.0	26.5
301	80	50	M6	95	14*30	4	119.5	45
401	90	80	M6	100	14*30	4	119.5	45
501	100	95	M8	115	14*30	4	119.5	45

Table 11.3.16-1

The dimensions e and e1 will change for the coupling type “clamping hub with groove” (KNN). Please contact us for consultation!

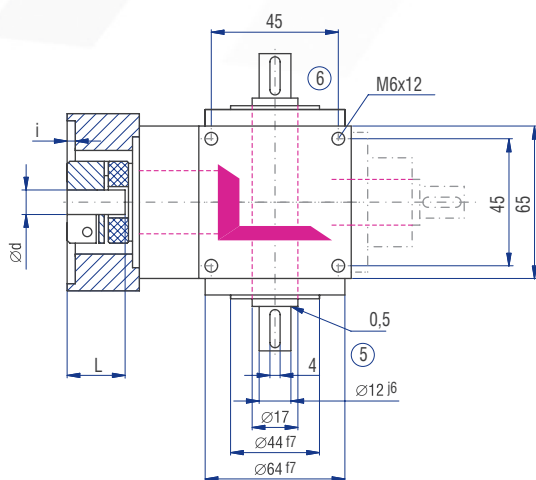
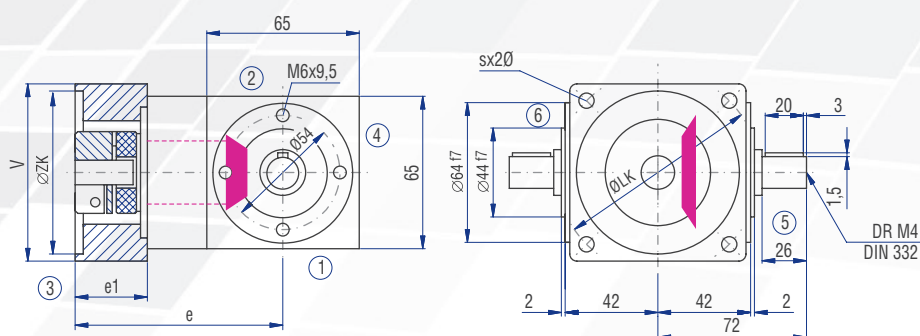
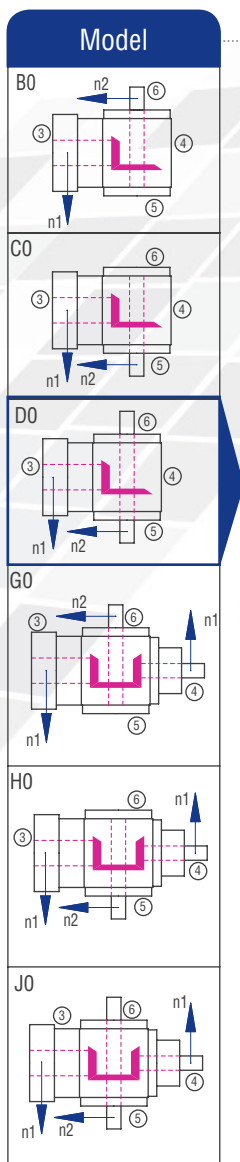

## Implementation VV

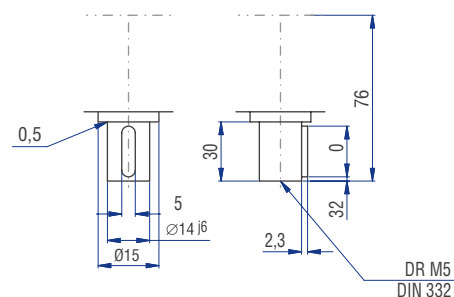

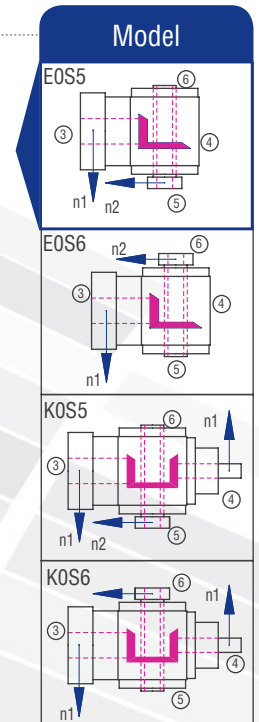
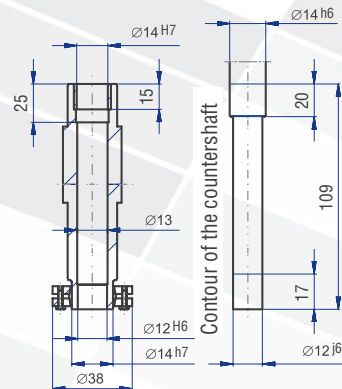
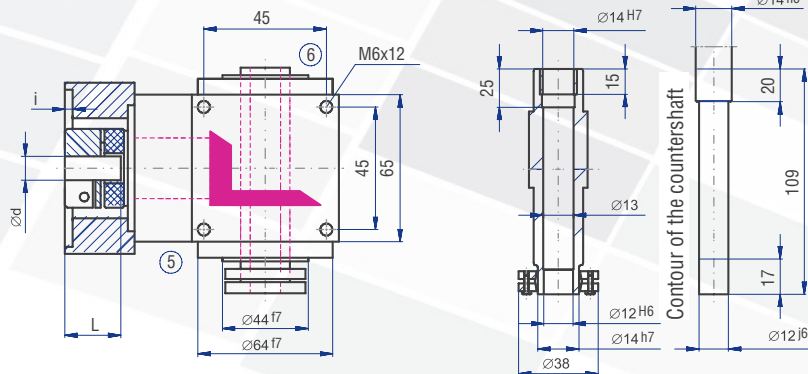
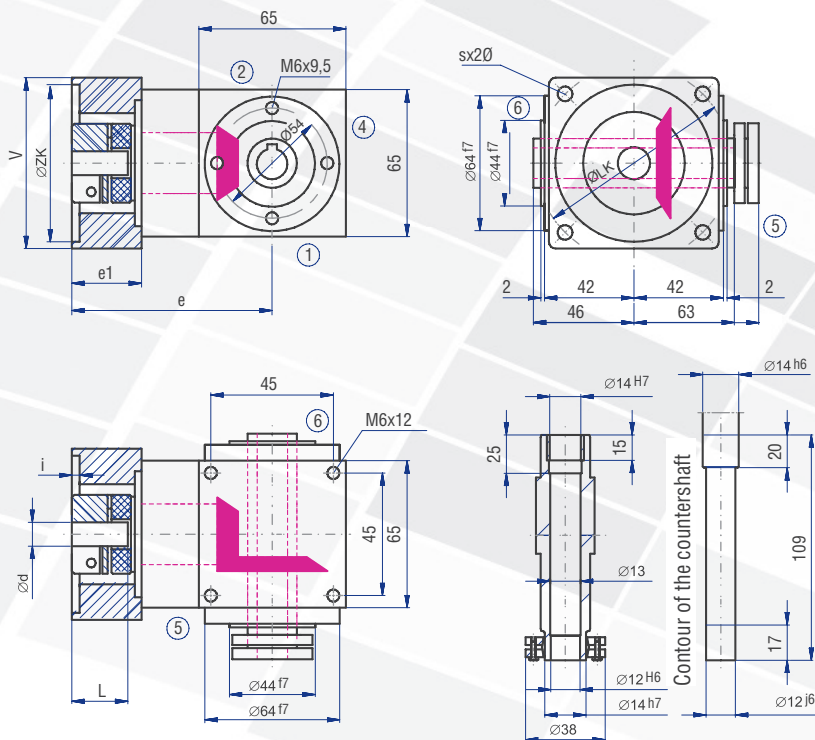
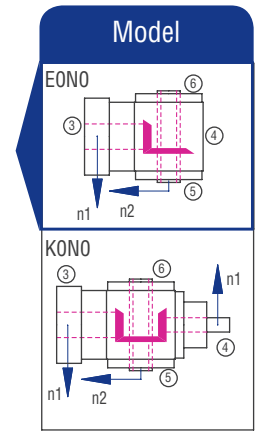
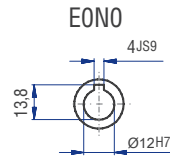
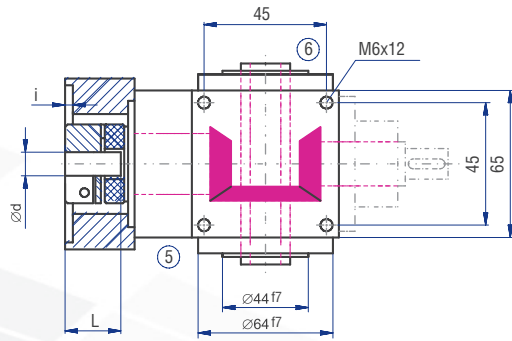
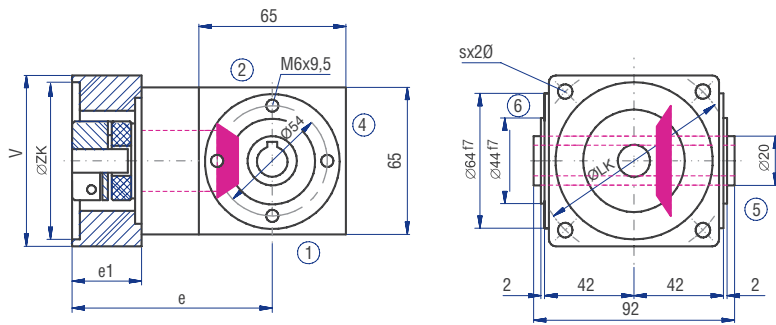

Servo gearboxes  
(precision gearboxes)

ANSI 3100  
ANSI 3100



## 11.3.17 Type VC 090 – Servo bevel gearboxes



### Characteristics

Characteristic	Standard	Option
<b>Toothing</b>	Spiral-toothed, hardened bevel gears	See chapter 11.3.2
<b>Gear ratio</b>	1:1 to 6:1	
<b>Housing / Flanges</b>	Grey cast iron / aluminium	
<b>Threaded mounting holes</b>	On all housing surfaces without flange and on all flanges.	See chapter 11.3.4
<b>Shaft</b>	Material 1 C45, shaft ends greased Fit with ISO 6 tolerance with parallel keyway: according to DIN 6885 Sheet 1	See chapter 4.6.2
<b>Hollow shaft</b>	Material 1 C45, shafts greased Fit with ISO 7 tolerance with parallel keyway: according to DIN 6885 Sheet 1	See chapter 4.6.3
<b>Radial shaft seal ring</b>	NBR, form A	See chapter 4.8
<b>Ambient temperature</b>	-10°C to +90°C. The values of the performance tables are valid for +20°C	See chapter 4.9.3
<b>Circumferential backlash</b>	< 20 arcmin	See chapter 11.3.11
<b>Protection class</b>	IP 54	See chapter 4.5
<b>Corrosion protection</b>	Prime coat; layer thickness > 40 µm	See chapter 4.4.1
<b>Bearing life L10h</b>	more than 15,000h	See chapter 4.9.1
<b>Oil change intervals</b>	Not required if the oil temperature is kept < 90°C The lifetime of the bearings can be increased by the factor 1.5 if the oil is changed after the first 500 service hours and then every 5000 service hours.	See chapter 11.3.9
<b>Lubricants</b>	Synthetic lubricants	See chapter 11.3.9
<b>Motor flange</b>	Aluminium	See chapter 11.3.14
<b>Coupling</b>	Insertable, flexible claw coupling, suitable for servo-motors For smooth motor shafts                      clamping hub For smooth motor shafts                      tension ring hub For motor shafts with parallel key        clamping hub with groove	KN SN KNN See chapter 11.3.13

### Torques in operating mode S1

Gear ratio i [-]	1:1		1.5:1		2:1		3:1		4:1		5:1		6:1	
	n <sub>1</sub> [rpm]	T <sub>2N</sub> [Nm]	n <sub>2</sub> [rpm]	T <sub>2N</sub> [Nm]	n <sub>2</sub> [rpm]	T <sub>2N</sub> [Nm]	n <sub>2</sub> [rpm]	T <sub>2N</sub> [Nm]	n <sub>2</sub> [rpm]	T <sub>2N</sub> [Nm]	n <sub>2</sub> [rpm]	T <sub>2N</sub> [Nm]	n <sub>2</sub> [rpm]	T <sub>2N</sub> [Nm]
<b>4000</b>	8	4000	12	2667	17	2000	21	1333	21	1000	21	800	21	667
<b>3000</b>	11	3000	17	2000	23	1500	23	1000	23	750	23	600	23	500
<b>2400</b>	14	2400	21	1600	24	1200	24	800	25	600	25	480	25	400
<b>1500</b>	17	1500	25	1000	27	750	27	500	27	375	27	300	27	250

## Torques in operating mode S5, dynamic operation

Gear ratio i [-]		1:1	1.5:1	2:1	3:1	4:1	5:1	6:1		
$T_{2N}$ in S5 [Nm]		25	25	25	23	23	23	23		
$n_{1max}$ in S5 [rpm]		3200	4800	6000	6000	6000	6000	6000		
Coupling size	Motor shaft d [mm]	Coupling type	1:1	1.5:1	2:1	3:1	4:1	5:1	6:1	
K19	9	KN	$T_{2B}$ [Nm]	17.0	25.5	34.0	36.0	36.0	36.0	31.0
			$T_{2NOT}$ [Nm]	30.0	45.0	60.0	60.0	60.0	50.0	45.0
	11	KN	$T_{2B}$ [Nm]	17.0	25.5	34.0	36.0	36.0	36.0	31.0
			$T_{2NOT}$ [Nm]	30.0	45.0	60.0	60.0	60.0	50.0	45.0
		KNN	$T_{2B}$ [Nm]	17.0	25.5	34.0	36.0	36.0	36.0	31.0
			$T_{2NOT}$ [Nm]	30.0	45.0	60.0	60.0	60.0	50.0	45.0
	14	KN	$T_{2B}$ [Nm]	17.0	25.5	34.0	36.0	36.0	36.0	31.0
			$T_{2NOT}$ [Nm]	32.0	48.0	60.0	60.0	60.0	50.0	45.0
		KNN	$T_{2B}$ [Nm]	17.0	25.5	34.0	36.0	36.0	36.0	31.0
			$T_{2NOT}$ [Nm]	32.0	48.0	60.0	60.0	60.0	50.0	45.0
	16	KN	$T_{2B}$ [Nm]	17.0	25.5	34.0	36.0	36.0	36.0	31.0
			$T_{2NOT}$ [Nm]	32.0	48.0	60.0	60.0	60.0	50.0	45.0
		KNN	$T_{2B}$ [Nm]	17.0	25.5	34.0	36.0	36.0	36.0	31.0
			$T_{2NOT}$ [Nm]	34.0	50.0	60.0	60.0	60.0	50.0	45.0
	19	KN	$T_{2B}$ [Nm]	17.0	25.5	34.0	36.0	36.0	36.0	31.0
			$T_{2NOT}$ [Nm]	34.0	50.0	60.0	60.0	60.0	50.0	45.0
		KNN	$T_{2B}$ [Nm]	17.0	25.5	34.0	36.0	36.0	36.0	31.0
			$T_{2NOT}$ [Nm]	34.0	50.0	60.0	60.0	60.0	50.0	45.0
	24	KN	$T_{2B}$ [Nm]	17.0	25.5	34.0	36.0	36.0	36.0	31.0
			$T_{2NOT}$ [Nm]	34.0	50.0	60.0	60.0	60.0	50.0	45.0

## Permissible radial force $F_{r2}$ and axial force $F_{a2}$ on shaft $N_2$

$n_2$ [rpm]	3000		1000		500		250		100		50	
	$T_2$ [Nm]	$F_r$ [N]	$F_a$ [N]	$F_r$ [N]	$F_a$ [N]	$F_r$ [N]	$F_a$ [N]	$F_r$ [N]	$F_a$ [N]	$F_r$ [N]	$F_a$ [N]	
< 30	500	250	660	330	800	400	950	475	1250	625	1500	750
> 30	420	210	550	275	670	335	790	395	1040	520	1250	625

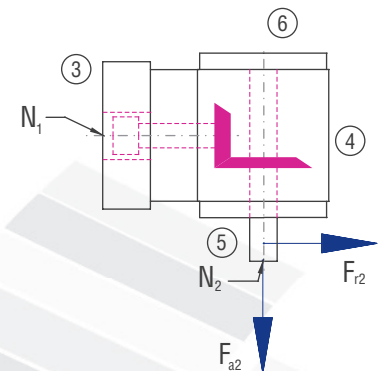

Servo gearboxes  
(precision gearboxes)

## Gearbox inertia moments/mass

Inertia moment  $J_1$  related to the fast-rotating shaft ( $N_1$ )

Model	Inertia moment [kgcm <sup>2</sup> ]						
	1:1	1.5:1	2:1	3:1	4:1	5:1	6:1
AO	3.0540	2.3340	1.4510	1.2330	1.1450	1.1010	1.0700
BO	3.6690	2.7900	1.6950	1.3410	1.2060	1.1400	1.0970
CO	3.6690	2.7900	1.6950	1.3410	1.2060	1.1401	1.0970
DO	3.6974	2.8023	1.7020	1.3441	1.2075	1.1412	1.0980
EON	3.5654	2.7440	1.6690	1.3294	1.1992	1.1360	1.0940
EOS	4.2360	3.0420	1.8370	1.4040	1.2412	1.1630	1.1130
FO	4.5140	3.1480	1.7490	1.4240	1.2610	1.1820	1.1220
GO	4.9490	3.7030	2.5190	2.0870	1.4890	1.4140	1.3670
HO	4.9490	3.7030	2.5190	2.0870	1.4890	1.4140	1.3670
JO	4.9770	3.7160	2.5260	2.0900	1.4910	1.4150	1.3680
KON	4.8450	3.6570	2.4930	2.0760	1.4820	1.4100	1.3650
KOS	5.5160	3.9550	2.6600	2.1500	1.5240	1.4360	1.3830

## Inertia moments Coupling J [kgcm<sup>2</sup>]

K19 d [mm]	KN	KNN	SN
	J [kgcm <sup>2</sup> ]	J [kgcm <sup>2</sup> ]	J [kgcm <sup>2</sup> ]
9	0.204	0.204	0.315
11	0.204	0.204	0.314
14	0.202	0.202	0.310
16	0.200	0.200	0.298
19	0.196	0.196	0.293
24	0.000	0.000	0.000

Mass ca. [kg]
6.6
6.9
6.9
7.0
6.5
6.7
7.8
8.4
8.4
8.5
8.0
8.2

The mass of the gearbox may deviate depending on the flange size and the gear ratio.

# 11.3.17 Type VC 090 – Servo bevel gearboxes

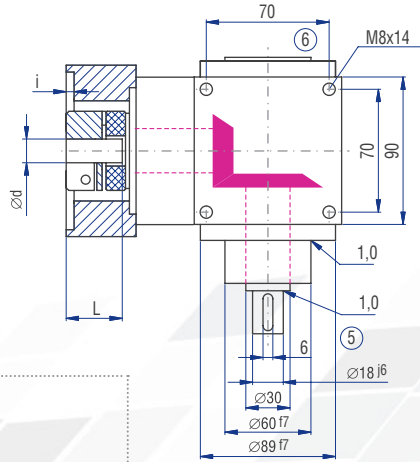
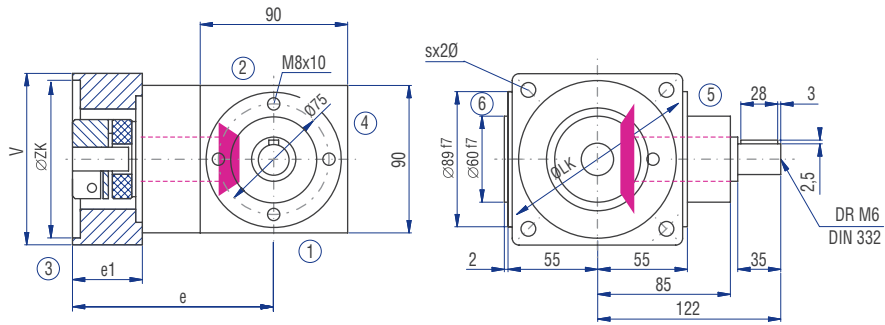
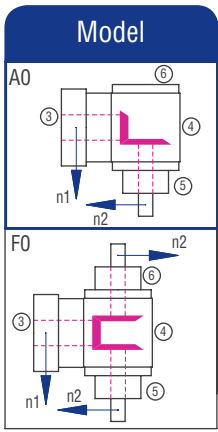

## Motor mounting dimensions

Flange no.	V [mm]	ZK [mm]	Thread	LK [mm]	Shaft dxL [mm]	i [mm]	e [mm]	e1 [mm]
103	90	60	M6	75	19°40	3	140.0	45
201	90	60	M5	90	19°40	3	140.0	45
301	90	50	M6	95	19°40	4	140.0	45
401	90	80	M6	100	19°40	4	140.0	45
501	100	95	M8	115	19°40	4	140.0	45
601	115	95	M8	130	19°40	4	140.0	45
611	115	110	M8	130	19°40	5	140.0	45
701	120	110	M8	145	19°40	5	140.0	45
802	140	110	M10	165	19°40	5		45

Table 11.3.17-1

The dimensions e and e1 will change for the coupling type "clamping hub with groove" (KNN). Please contact us for consultation!

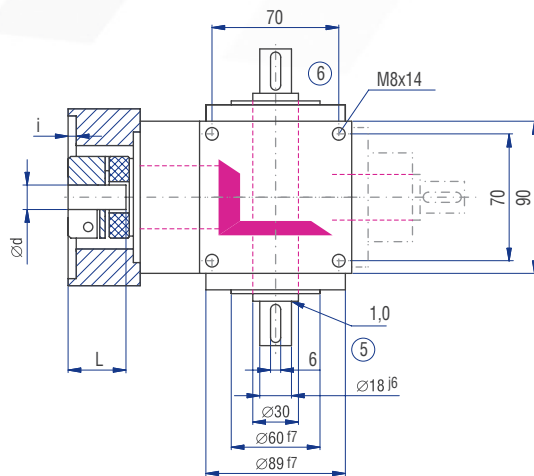
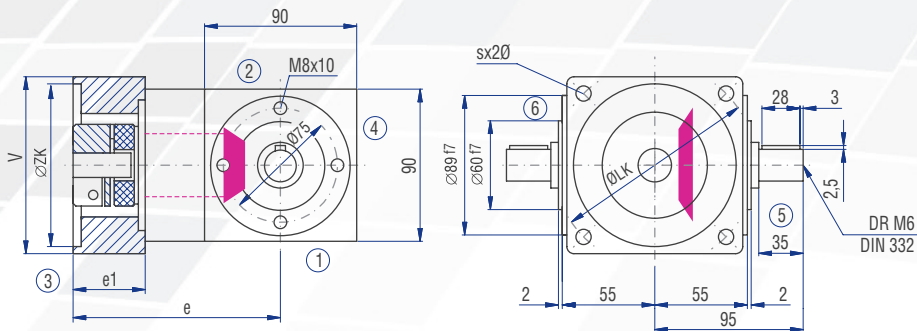
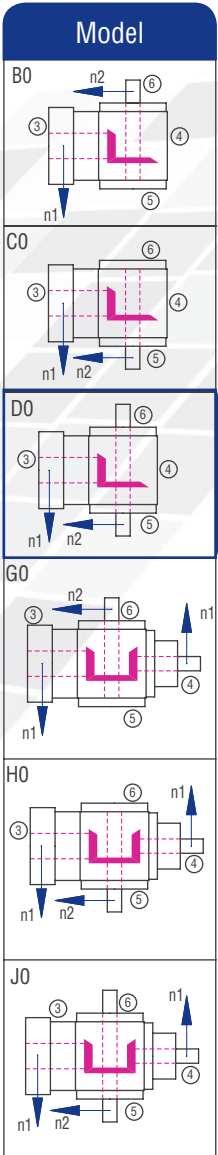

## Implementation VV

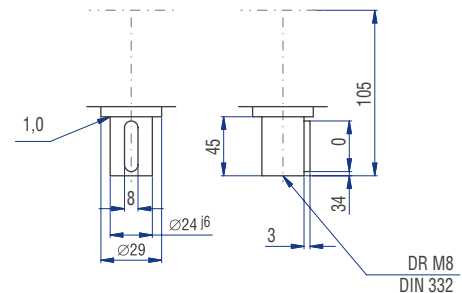

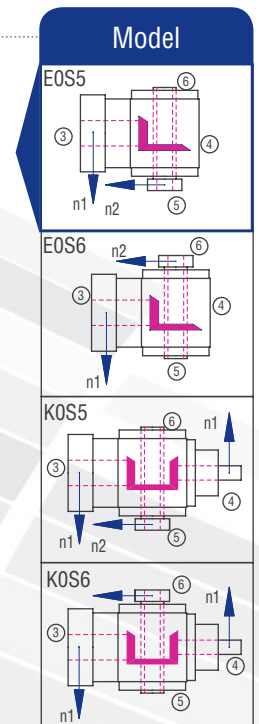
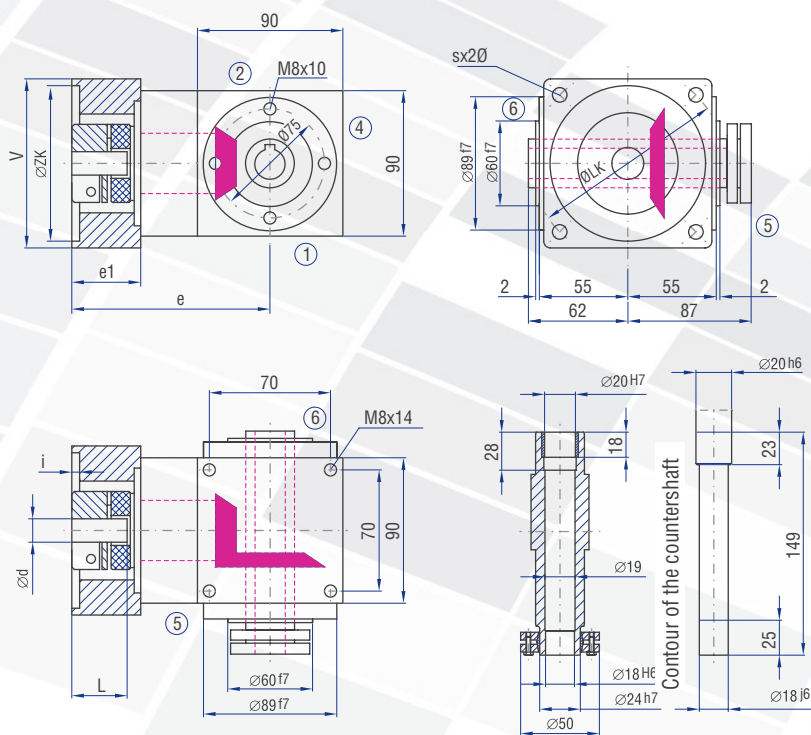
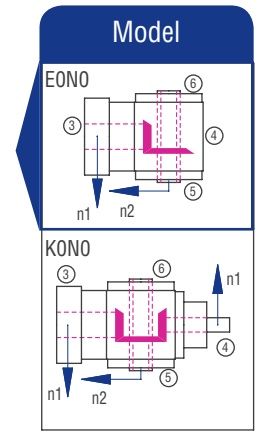
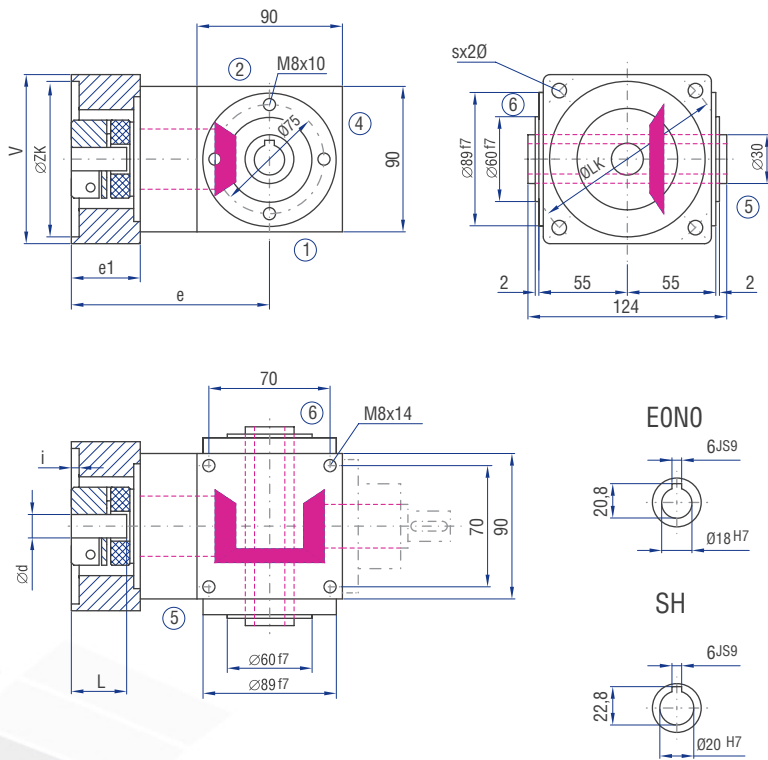

Servo gearboxes  
(precision gearboxes)

## 11.3.18 Type VC 120 – Servo bevel gearboxes



### Characteristics

Characteristic	Standard	Option
<b>Toothing</b>	Spiral-toothed, hardened bevel gears	See chapter 11.3.2
<b>Gear ratio</b>	1:1 to 6:1	
<b>Housing / Flanges</b>	Grey cast iron / aluminium	
<b>Threaded mounting holes</b>	On all housing surfaces without flange and on all flanges.	See chapter 11.3.4
<b>Shaft</b>	Material 1 C45, shaft ends greased Fit with ISO 6 tolerance with parallel keyway: according to DIN 6885 Sheet 1	See chapter 4.6.2
<b>Hollow shaft</b>	Material 1 C45, shafts greased Fit with ISO 7 tolerance with parallel keyway: according to DIN 6885 Sheet 1	See chapter 4.6.3
<b>Radial shaft seal ring</b>	NBR, form A	See chapter 4.8
<b>Ambient temperature</b>	-10°C to +90°C. The values of the performance tables are valid for +20°C	See chapter 4.9.3
<b>Circumferential backlash</b>	< 20 arcmin	See chapter 11.3.11
<b>Protection class</b>	IP 54	See chapter 4.5
<b>Corrosion protection</b>	Prime coat; layer thickness > 40 µm	See chapter 4.4.1
<b>Bearing life L10h</b>	more than 15,000h	See chapter 4.9.1
<b>Oil change intervals</b>	Not required if the oil temperature is kept < 90°C The lifetime of the bearings can be increased by the factor 1.5 if the oil is changed after the first 500 service hours and then every 5000 service hours.	See chapter 11.3.9
<b>Lubricants</b>	Synthetic lubricants	See chapter 11.3.9
<b>Motor flange</b>	Aluminium	See chapter 11.3.14
<b>Coupling</b>	Insertable, flexible claw coupling, suitable for servo-motors For smooth motor shafts                      clamping hub For smooth motor shafts                      tension ring hub For motor shafts with parallel key        clamping hub with groove	KN SN KNN See chapter 11.3.13

### Torques in operating mode S1

Gear ratio i [-]	1:1		1.5:1		2:1		3:1		4:1		5:1		6:1		
	n1 [rpm]	T <sub>2N</sub> [Nm]	n <sub>2</sub> [rpm]	T <sub>2N</sub> [Nm]	n <sub>2</sub> [rpm]	T <sub>2N</sub> [Nm]	n <sub>2</sub> [rpm]	T <sub>2N</sub> [Nm]	n <sub>2</sub> [rpm]	T <sub>2N</sub> [Nm]	n <sub>2</sub> [rpm]	T <sub>2N</sub> [Nm]	n <sub>2</sub> [rpm]	T <sub>2N</sub> [Nm]	
<b>4000</b>			4000	21	2667	28	2000	42	1333	52	1000	52	800	45	667
<b>3000</b>	18		3000	28	2000	37	1500	56	1000	60	750	60	600	54	500
<b>2400</b>	23		2400	35	1600	46	1200	63	800	67	600	65	480	59	400
<b>1500</b>	37		1500	56	1000	73	750	74	500	74	375	72	300	64	250

## Torques in operating mode S5, dynamic operation

Gear ratio i [-]			1:1	1.5:1	2:1	3:1	4:1	5:1	6:1	
T <sub>2N</sub> in S5 [Nm]			50	61	65	58	60	60	54	
n <sub>1max</sub> in S5 [rpm]			2400	3600	4800	6000	6000	6000	6000	
Coupling size	Motor shaft d [mm]	Coupling type	1:1	1.5:1	2:1	3:1	4:1	5:1	6:1	
K24	11	KN	T <sub>2B</sub> [Nm]	35.0	52.5	70.0	95.0	87.0	92.0	71.0
			T <sub>2NOT</sub> [Nm]	45.0	67.5	90.0	135.0	140.0	120.0	110.0
		KNN	T <sub>2B</sub> [Nm]	48.0	72.0	96.0	95.0	87.0	92.0	71.0
			T <sub>2NOT</sub> [Nm]	0.0	0.0	0.0	0.0	0.0	0.0	0.0
		SN	T <sub>2B</sub> [Nm]	48.0	72.0	96.0	95.0	87.0	92.0	71.0
			T <sub>2NOT</sub> [Nm]	0.0	0.0	0.0	0.0	0.0	0.0	0.0
	14	KN	T <sub>2B</sub> [Nm]	36.0	54.0	72.0	95.0	87.0	92.0	71.0
			T <sub>2NOT</sub> [Nm]	45.0	67.5	90.0	135.0	140.0	120.0	110.0
		KNN	T <sub>2B</sub> [Nm]	48.0	72.0	96.0	95.0	87.0	92.0	71.0
			T <sub>2NOT</sub> [Nm]	80.0	120.0	140.0	140.0	140.0	120.0	110.0
		SN	T <sub>2B</sub> [Nm]	48.0	72.0	96.0	95.0	87.0	92.0	71.0
			T <sub>2NOT</sub> [Nm]	80.0	120.0	140.0	140.0	140.0	120.0	110.0
	16	KN	T <sub>2B</sub> [Nm]	39.0	58.5	78.0	95.0	87.0	92.0	71.0
			T <sub>2NOT</sub> [Nm]	50.0	75.0	100.0	140.0	140.0	120.0	110.0
		KNN	T <sub>2B</sub> [Nm]	48.0	72.0	96.0	95.0	87.0	92.0	71.0
			T <sub>2NOT</sub> [Nm]	100.0	140.0	140.0	140.0	140.0	120.0	110.0
		SN	T <sub>2B</sub> [Nm]	48.0	72.0	96.0	95.0	87.0	92.0	71.0
			T <sub>2NOT</sub> [Nm]	100.0	140.0	140.0	140.0	140.0	120.0	110.0
	19	KN	T <sub>2B</sub> [Nm]	39.0	58.5	78.0	95.0	87.0	92.0	71.0
			T <sub>2NOT</sub> [Nm]	60.0	90.0	120.0	140.0	140.0	120.0	110.0
		KNN	T <sub>2B</sub> [Nm]	48.0	72.0	96.0	95.0	87.0	92.0	71.0
			T <sub>2NOT</sub> [Nm]	120.0	140.0	140.0	140.0	140.0	120.0	110.0
		SN	T <sub>2B</sub> [Nm]	48.0	72.0	96.0	95.0	87.0	92.0	71.0
			T <sub>2NOT</sub> [Nm]	120.0	140.0	140.0	140.0	140.0	120.0	110.0
	24	KN	T <sub>2B</sub> [Nm]	43.0	64.5	86.0	95.0	87.0	92.0	71.0
			T <sub>2NOT</sub> [Nm]	65.0	97.5	130.0	140.0	140.0	120.0	110.0
		KNN	T <sub>2B</sub> [Nm]	48.0	72.0	96.0	95.0	87.0	92.0	71.0
			T <sub>2NOT</sub> [Nm]	120.0	140.0	140.0	140.0	140.0	120.0	110.0
		SN	T <sub>2B</sub> [Nm]	48.0	72.0	96.0	95.0	87.0	92.0	71.0
			T <sub>2NOT</sub> [Nm]	120.0	140.0	140.0	140.0	140.0	120.0	110.0
	28	KN	T <sub>2B</sub> [Nm]	46.0	69.0	92.0	95.0	87.0	92.0	71.0
			T <sub>2NOT</sub> [Nm]	70.0	105.0	140.0	140.0	140.0	120.0	110.0
		KNN	T <sub>2B</sub> [Nm]	48.0	72.0	96.0	95.0	87.0	92.0	71.0
			T <sub>2NOT</sub> [Nm]	120.0	140.0	140.0	140.0	140.0	120.0	110.0
		SN	T <sub>2B</sub> [Nm]	48.0	72.0	96.0	95.0	87.0	92.0	71.0
			T <sub>2NOT</sub> [Nm]	120.0	140.0	140.0	140.0	140.0	120.0	110.0

## Permissible radial force F<sub>r2</sub> and axial force F<sub>a2</sub> on shaft N<sub>2</sub>

n <sub>2</sub> [rpm]	3000		1000		500		250		100		50	
	T <sub>2</sub> [Nm]	F <sub>r</sub> [N]	F <sub>a</sub> [N]	F <sub>r</sub> [N]	F <sub>a</sub> [N]	F <sub>r</sub> [N]	F <sub>a</sub> [N]	F <sub>r</sub> [N]	F <sub>a</sub> [N]	F <sub>r</sub> [N]	F <sub>a</sub> [N]	
< 80	750	375	1000	500	1250	625	1500	750	1900	950	2200	1100
> 80	630	315	830	415	1040	520	1250	625	1580	790	1830	915

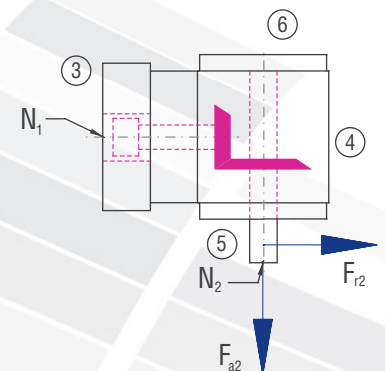

Servo gearboxes  
(precision gearboxes)

## Gearbox inertia moments/mass

Inertia moment J<sub>1</sub> related to the fast-rotating shaft (N<sub>1</sub>)

Model	Inertia moment [kgcm <sup>2</sup> ]							Mass ca. [kg]
	1:1	1.5:1	2:1	3:1	4:1	5:1	6:1	
AO	12.4450	6.8580	5.7210	4.6470	4.2780	4.0580	3.9250	17.6
BO	16.9680	8.8470	6.7790	5.1170	4.5420	4.2270	4.0430	17.3
CO	16.9680	8.8473	6.7790	5.1172	4.5420	4.2271	4.0430	17.3
DO	17.2660	8.9795	6.8534	5.1502	4.5610	4.2390	4.0511	17.5
EON	16.8600	8.7992	6.7520	5.1051	4.5352	4.2230	4.0400	17.0
EOS	18.6470	9.5940	7.1990	5.3040	4.6470	4.2942	4.0894	17.3
FO	17.9750	9.8050	7.3040	5.4560	4.7980	4.4060	4.1750	20.0
GO	22.2170	11.3550	9.1130	6.8500	5.4300	4.7690	4.5740	19.7
HO	22.2170	11.3550	9.1130	6.8500	5.4300	4.7690	4.5740	19.7
JO	22.5140	11.4880	9.1880	6.8830	5.4490	4.7810	4.5820	19.9
KON	22.1090	11.3070	9.0860	6.8380	5.4240	4.7640	4.5710	19.4
KOS	23.8960	12.1020	9.5330	7.0360	5.5350	4.8360	4.6200	19.7

## Inertia moments Coupling J [kgcm<sup>2</sup>]

K24	KN	KNN	SN
11	0.812	0.812	1.374
14	0.810	0.810	1.360
16	0.808	0.808	1.350
19	0.803	0.803	1.340
24	0.787	0.787	1.290
28	0.765	0.765	1.274

The mass of the gearbox may deviate depending on the flange size and the gear ratio.

**ATEK**  
ANTRIEBSTECHNIK

# 11.3.18 Type VC 120 – Servo bevel gearboxes

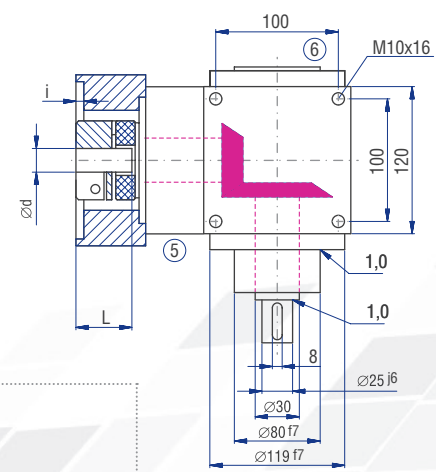
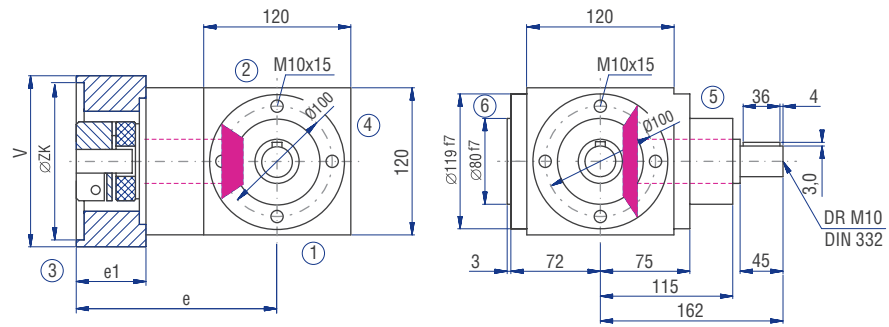
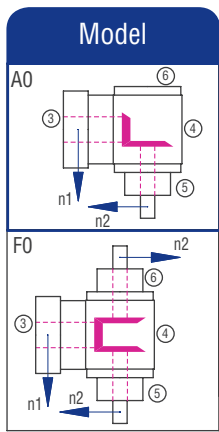

## Motor mounting dimensions

Flange no.	V [mm]	ZK [mm]	Thread	LK [mm]	Shaft dxL [mm]	i [mm]	e [mm]	e1 [mm]
103	120	60	M6	75	24*50	3	170.0	54
201	120	60	M5	90	24*50	3	170.0	54
301	120	50	M6	95	24*50	4	170.0	54
401	120	80	M6	100	24*50	4	170.0	54
501	120	95	M8	115	24*50	4	170.0	54
601	120	95	M8	130	24*50	4	170.0	54
611	120	110	M8	130	24*50	5	170.0	54
701	120	110	M8	145	24*50	5	170.0	54
802	140	110	M10	165	24*50	5	170.0	54
811	140	130	M10	165	24*50	5	170.0	54

Table 11.3.18-1

The dimensions e and e1 will change for the coupling type "clamping hub with groove" (KNN). Please contact us for consultation!

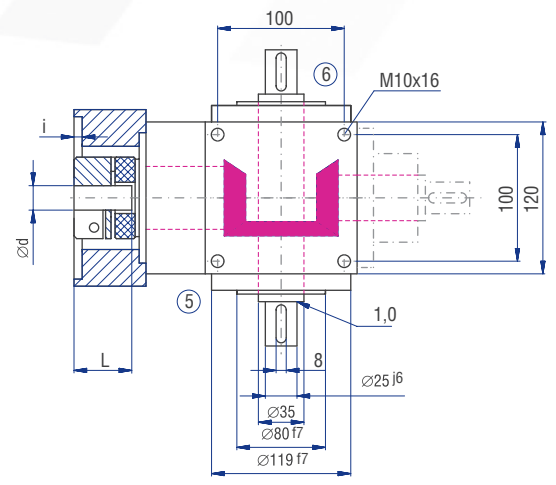
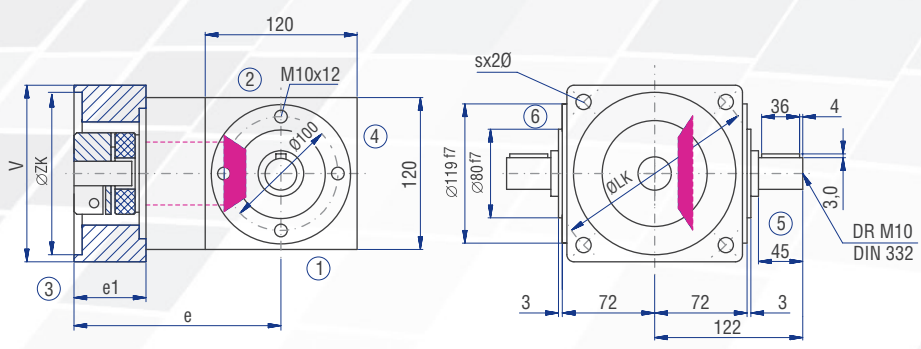
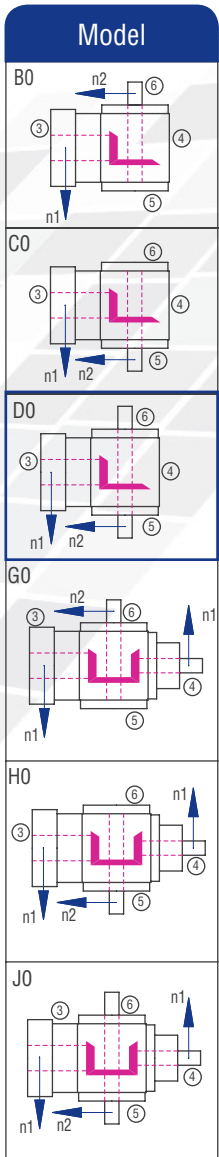

## Implementation VV

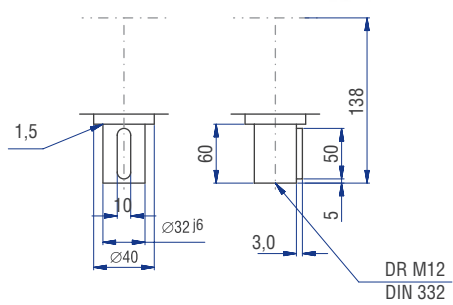

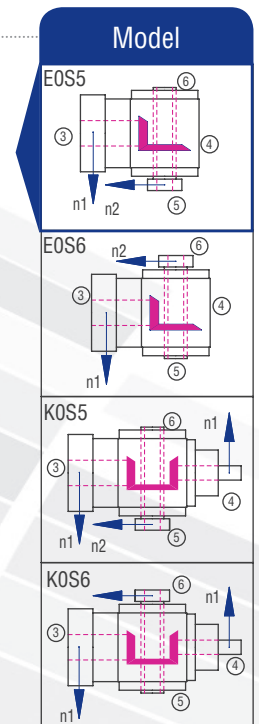
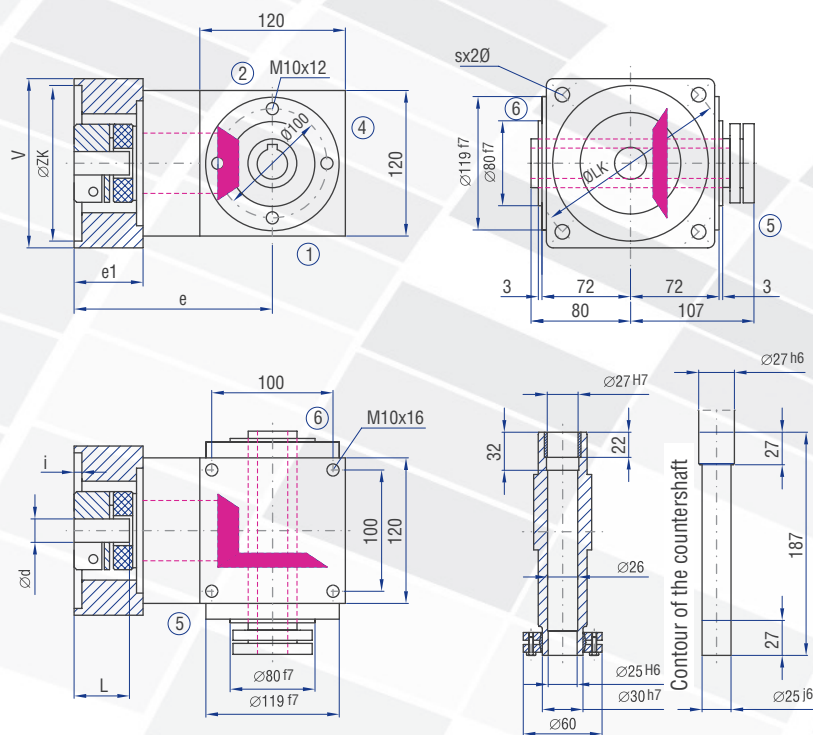
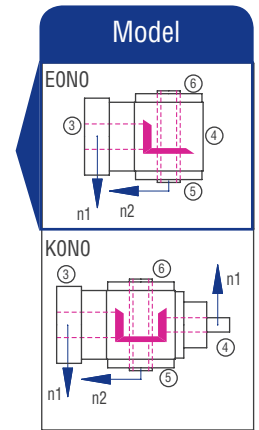
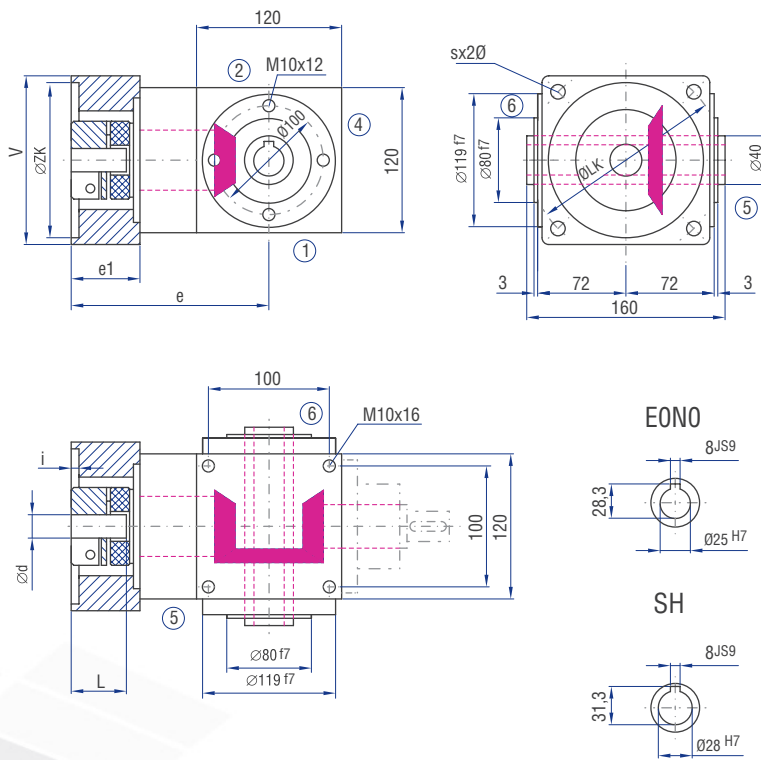

Servo gearboxes  
(precision gearboxes)

Model  
(see page 287)



## 11.3.19 Type VC 140 – Servo bevel gearboxes

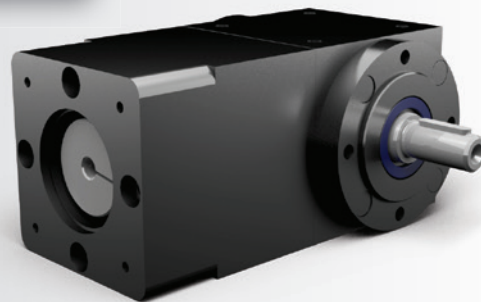

### Characteristics

Characteristic	Standard	Option
<b>Toothing</b>	Spiral-toothed, hardened bevel gears	See chapter 11.3.2
<b>Gear ratio</b>	1:1 to 6:1	
<b>Housing / Flanges</b>	Grey cast iron / aluminium	
<b>Threaded mounting holes</b>	On all housing surfaces without flange and on all flanges.	See chapter 11.3.4
<b>Shaft</b>	Material 1 C45, shaft ends greased Fit with ISO 6 tolerance with parallel keyway: according to DIN 6885 Sheet 1	See chapter 4.6.2
<b>Hollow shaft</b>	Material 1 C45, shafts greased Fit with ISO 7 tolerance with parallel keyway: according to DIN 6885 Sheet 1	See chapter 4.6.3
<b>Radial shaft seal ring</b>	NBR, form A	See chapter 4.8
<b>Ambient temperature</b>	-10°C to +90°C. The values of the performance tables are valid for +20°C	See chapter 4.9.3
<b>Circumferential backlash</b>	< 20 arcmin	See chapter 11.3.11
<b>Protection class</b>	IP 54	See chapter 4.5
<b>Corrosion protection</b>	Prime coat; layer thickness > 40 µm	See chapter 4.4.1
<b>Bearing life L10h</b>	more than 15,000h	See chapter 4.9.1
<b>Oil change intervals</b>	Not required if the oil temperature is kept < 90°C The lifetime of the bearings can be increased by the factor 1.5 if the oil is changed after the first 500 service hours and then every 5000 service hours.	See chapter 11.3.9
<b>Lubricants</b>	Synthetic lubricants	See chapter 11.3.9
<b>Motor flange</b>	Aluminium	See chapter 11.3.14
<b>Coupling</b>	Insertable, flexible claw coupling, suitable for servo-motors For smooth motor shafts                      clamping hub For smooth motor shafts                      tension ring hub For motor shafts with parallel key        clamping hub with groove	KN SN KNN See chapter 11.3.13

### Torques in operating mode S1

Gear ratio i [-]	1:1		1.5:1		2:1		3:1		4:1		5:1		6:1		
	n <sub>1</sub> [rpm]	T <sub>2N</sub> [Nm]	n <sub>2</sub> [rpm]	T <sub>2N</sub> [Nm]	n <sub>2</sub> [rpm]	T <sub>2N</sub> [Nm]	n <sub>2</sub> [rpm]	T <sub>2N</sub> [Nm]	n <sub>2</sub> [rpm]	T <sub>2N</sub> [Nm]	n <sub>2</sub> [rpm]	T <sub>2N</sub> [Nm]	n <sub>2</sub> [rpm]	T <sub>2N</sub> [Nm]	
<b>4000</b>			4000	34	2667	45	2000	68	1333	85	1000	90	800	85	667
<b>3000</b>			3000	45	2000	60	1500	90	1000	103	750	100	600	95	500
<b>2400</b>	37		2400	56	1600	75	1200	113	800	111	600	105	480	102	400
<b>1500</b>	60		1500	90	1000	120	750	130	500	120	375	115	300	108	250

## Torques in operating mode S5, dynamic operation

Gear ratio i [-]				1:1	1.5:1	2:1	3:1	4:1	5:1	6:1
$T_{2N}$ in S5 [Nm]				120	113	110	110	105	100	95
$n_{1max}$ in S5 [rpm]				2100	3000	4200	5000	6000	6000	6000
Coupling size	Motor shaft d [mm]	Coupling type		1:1	1.5:1	2:1	3:1	4:1	5:1	6:1
K28	14	KN	$T_{2B}$ [Nm]	80.0	120.0	160.0	177.0	162.0	143.0	122.0
			$T_{2NOT}$ [Nm]	80.0	120.0	160.0	240.0	260.0	220.0	200.0
	16	KN	$T_{2B}$ [Nm]	81.0	121.5	162.0	177.0	162.0	143.0	122.0
			$T_{2NOT}$ [Nm]	100.0	150.0	200.0	260.0	260.0	220.0	200.0
		KNN	$T_{2B}$ [Nm]	128.0	192.0	190.0	177.0	162.0	143.0	122.0
			$T_{2NOT}$ [Nm]	140.0	210.0	280.0	260.0	260.0	220.0	200.0
	19	SN	$T_{2B}$ [Nm]	128.0	192.0	190.0	177.0	162.0	143.0	122.0
			$T_{2NOT}$ [Nm]	140.0	210.0	280.0	260.0	260.0	220.0	200.0
		KN	$T_{2B}$ [Nm]	85.0	127.5	170.0	177.0	162.0	143.0	122.0
			$T_{2NOT}$ [Nm]	130.0	195.0	260.0	260.0	260.0	220.0	200.0
	24	KNN	$T_{2B}$ [Nm]	128.0	192.0	190.0	177.0	162.0	143.0	122.0
			$T_{2NOT}$ [Nm]	240.0	280.0	280.0	260.0	260.0	220.0	200.0
		SN	$T_{2B}$ [Nm]	128.0	192.0	190.0	177.0	162.0	143.0	122.0
			$T_{2NOT}$ [Nm]	240.0	280.0	280.0	260.0	260.0	220.0	200.0
	28	KN	$T_{2B}$ [Nm]	91.0	136.5	182.0	177.0	162.0	143.0	122.0
			$T_{2NOT}$ [Nm]	140.0	210.0	280.0	260.0	260.0	220.0	200.0
		KNN	$T_{2B}$ [Nm]	128.0	192.0	190.0	177.0	162.0	143.0	122.0
			$T_{2NOT}$ [Nm]	240.0	280.0	280.0	260.0	260.0	220.0	200.0
	32	SN	$T_{2B}$ [Nm]	128.0	192.0	190.0	177.0	162.0	143.0	122.0
			$T_{2NOT}$ [Nm]	240.0	280.0	280.0	260.0	260.0	220.0	200.0
		KN	$T_{2B}$ [Nm]	102.0	153.0	190.0	177.0	162.0	143.0	122.0
			$T_{2NOT}$ [Nm]	156.0	234.0	280.0	260.0	260.0	220.0	200.0
	38	KNN	$T_{2B}$ [Nm]	128.0	192.0	190.0	177.0	162.0	143.0	122.0
			$T_{2NOT}$ [Nm]	240.0	280.0	280.0	260.0	260.0	220.0	200.0
		SN	$T_{2B}$ [Nm]	128.0	192.0	190.0	177.0	162.0	143.0	122.0
			$T_{2NOT}$ [Nm]	240.0	280.0	280.0	260.0	260.0	220.0	200.0

## Permissible radial force $F_{r2}$ and axial force $F_{a2}$ on shaft $N_2$

$n_2$ [rpm]	3000		1000		500		250		100		50	
	$T_2$ [Nm]	$F_r$ [N]	$F_a$ [N]	$F_r$ [N]	$F_a$ [N]	$F_r$ [N]	$F_a$ [N]	$F_r$ [N]	$F_a$ [N]	$F_r$ [N]	$F_a$ [N]	
< 140	1300	650	1700	850	2000	1000	2500	1250	3000	1500	3800	1900
> 140	1082	541	1420	710	1670	835	2080	1040	2500	1250	3170	1585

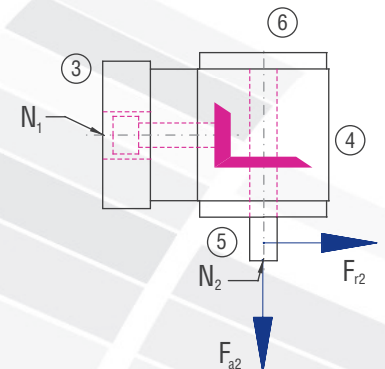

## Gearbox inertia moments/mass

Inertia moment  $J_1$  related to the fast-rotating shaft ( $N_1$ )

Model	Inertia moment [kgcm <sup>2</sup> ]							Mass ca. [kg]
	1:1	1.5:1	2:1	3:1	4:1	5:1	6:1	
AO	29.1040	17.6100	13.2250	10.3390	9.2700	8.8650	8.6550	26.0
BO	40.2700	22.7860	16.3860	11.4390	9.7640	9.2930	8.9250	25.5
CO	40.2700	22.7860	16.3860	11.4390	9.7640	9.2930	8.9250	25.5
DO	41.2520	23.2230	16.6310	11.5480	9.8250	9.3320	8.9520	26.0
EON	36.8340	21.2590	15.5260	11.0570	9.5490	9.1560	8.8300	25.0
EOS	43.2350	24.1040	17.1270	11.7690	9.9490	9.4120	9.0070	25.7
FO	40.9040	25.1660	16.9500	12.2160	10.4510	9.6410	9.2220	30.0
GO	53.4040	28.8060	21.7780	16.4150	10.7860	10.3000	9.9310	29.7
HO	53.4040	28.8060	21.7780	16.4150	10.7860	10.3000	9.9310	29.7
JO	54.3860	29.2430	22.0240	16.5250	10.8480	10.3390	9.9580	30.2
KON	49.9670	27.2790	20.9190	16.0340	10.5720	10.1620	9.8360	29.2
KOS	56.3690	30.1240	22.5200	16.7450	10.9720	10.4180	10.0130	29.9

## Inertia moments Coupling J [kgcm<sup>2</sup>]

K28	KN	KNN	SN
d [mm]	J [kgcm <sup>2</sup> ]	J [kgcm <sup>2</sup> ]	J [kgcm <sup>2</sup> ]
14	0.000	0.000	0.000
16	1.827	1.827	3.366
19	1.821	1.821	3.350
24	1.804	1.804	3.270
28	1.779	1.779	3.190
32	1.741	1.741	3.030
38	1.649	1.649	2.898

# 11.3.19 Type VC 140 – Servo bevel gearboxes

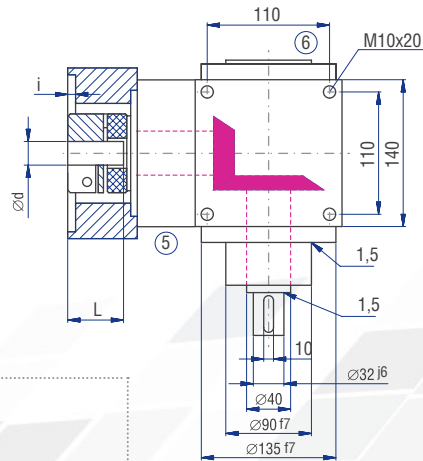
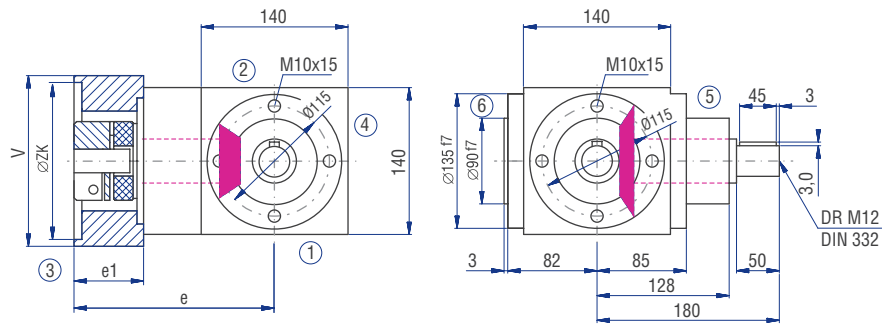
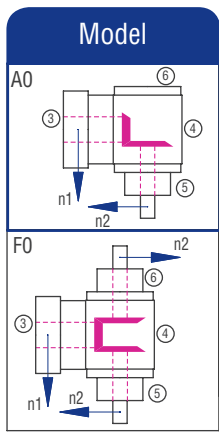

## Motor mounting dimensions

Flange no.	V [mm]	ZK [mm]	Thread	LK [mm]	Shaft dxL [mm]	i [mm]	e [mm]	e1 [mm]
403	140	80	M6	100	32*60	4	196.0	61
502	140	95	M8	115	32*60	4	196.0	61
601	140	95	M8	130	32*60	4	196.0	61
611	140	110	M8	130	32*60	5	196.0	61
616	140	110	M10	130	32*60	5	196.0	61
701	140	110	M8	145	32*60	5	196.0	61
802	140	110	M10	165	32*60	5	196.0	61
811	140	130	M10	165	32*60	5	196.0	61
902	200	130	M12	215	32*60	6	196.0	61
911	200	180	M12	215	32*60	6	196.0	61
931	200	180	M12	215	38*80	6	241.0	107

Table 11.3.19-1

The dimensions e and e1 will change for the coupling type "clamping hub with groove" (KNN). Please contact us for consultation!

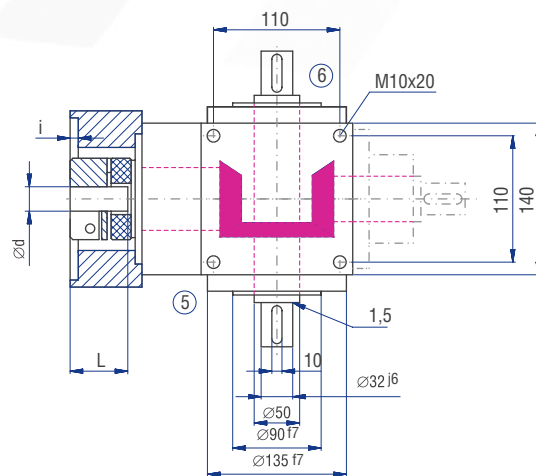
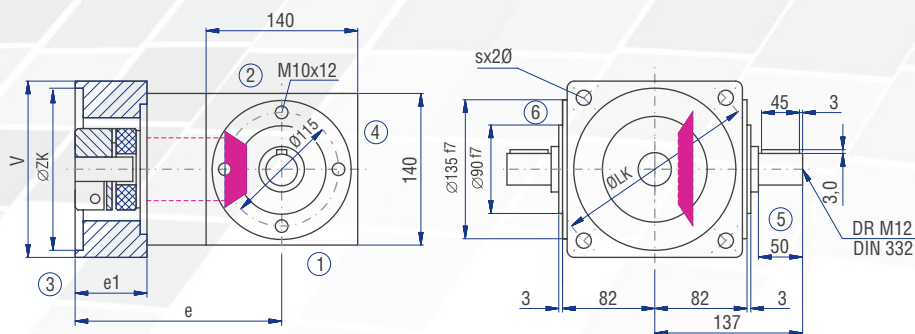
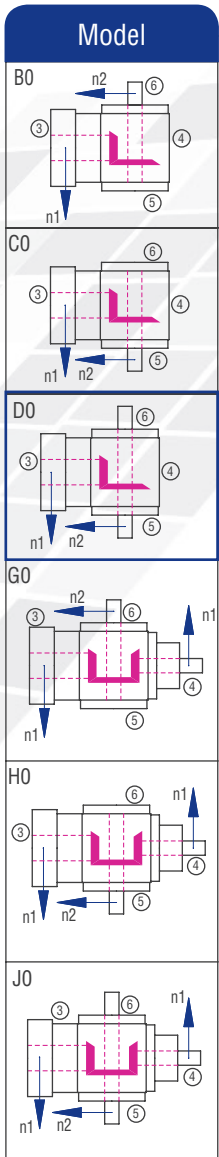

## Implementation VV

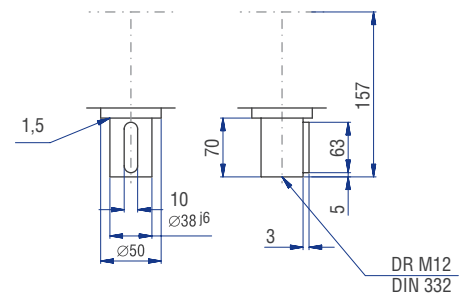

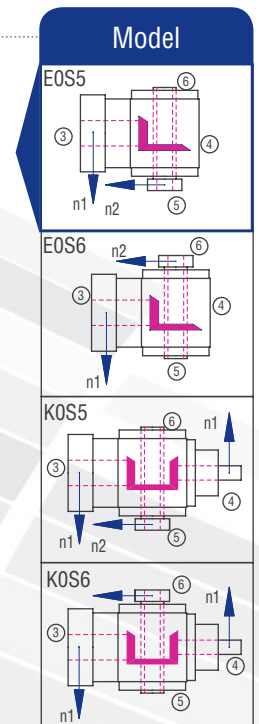
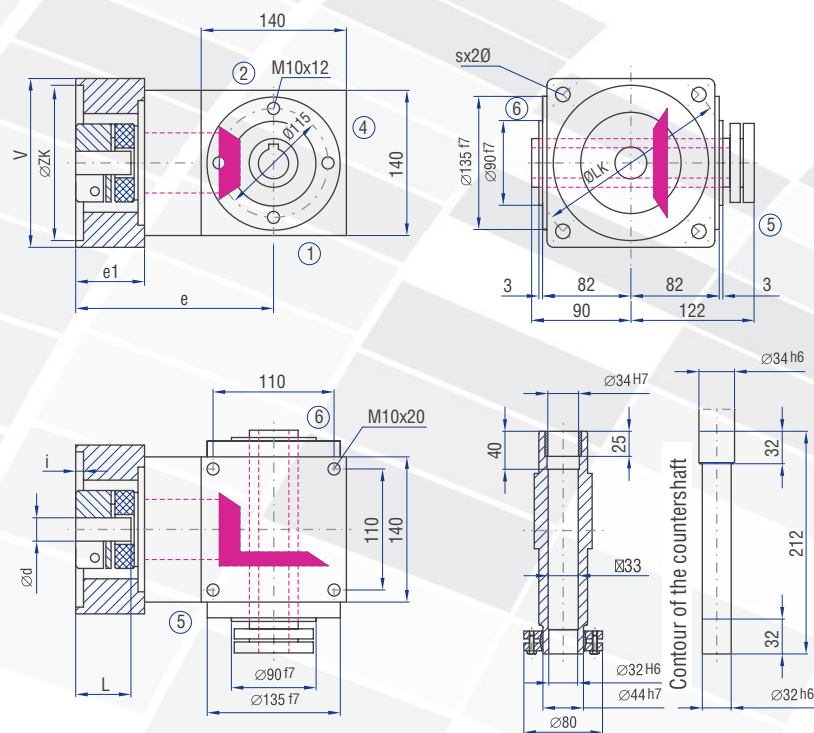
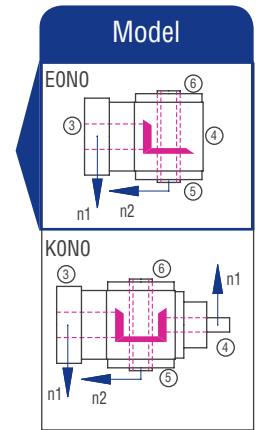
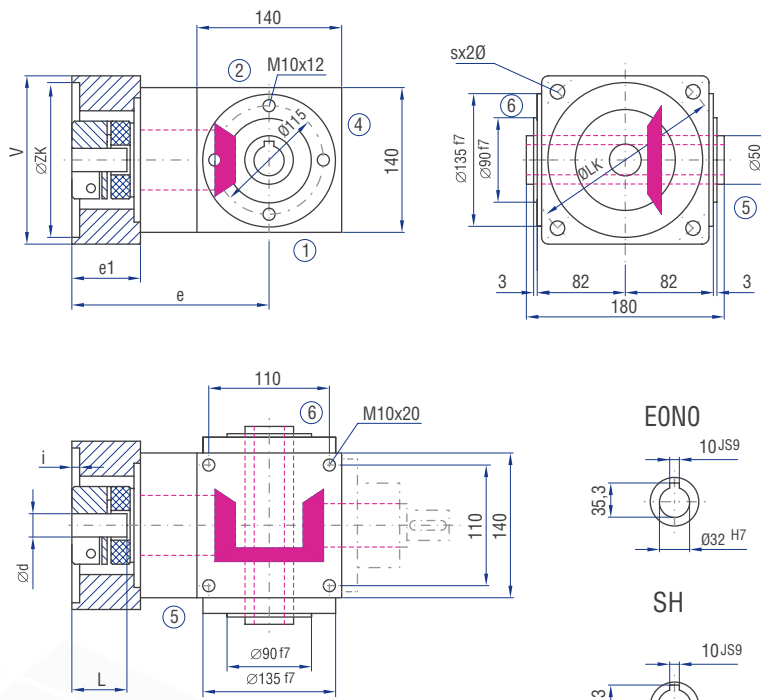

Servo gearboxes  
(precision gearboxes)

## 11.3.20 Type VC 160 – Servo bevel gearboxes

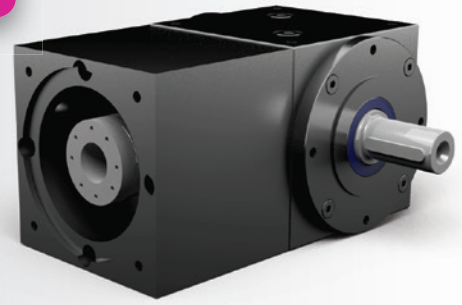

### Characteristics

Characteristic	Standard	Option
<b>Toothing</b>	Spiral-toothed, hardened bevel gears	See chapter 11.3.2
<b>Gear ratio</b>	1:1 to 6:1	
<b>Housing / Flanges</b>	Grey cast iron / aluminium	
<b>Threaded mounting holes</b>	On all housing surfaces without flange and on all flanges.	See chapter 11.3.4
<b>Shaft</b>	Material 1 C45, shaft ends greased Fit with ISO 6 tolerance with parallel keyway: according to DIN 6885 Sheet 1	See chapter 4.6.2
<b>Hollow shaft</b>	Material 1 C45, shafts greased Fit with ISO 7 tolerance with parallel keyway: according to DIN 6885 Sheet 1	See chapter 4.6.3
<b>Radial shaft seal ring</b>	NBR, form A	See chapter 4.8
<b>Ambient temperature</b>	-10°C to +90°C. The values of the performance tables are valid for +20°C	See chapter 4.9.3
<b>Circumferential backlash</b>	< 20 arcmin	See chapter 11.3.11
<b>Protection class</b>	IP 54	See chapter 4.5
<b>Corrosion protection</b>	Prime coat; layer thickness > 40 µm	See chapter 4.4.1
<b>Bearing life L10h</b>	more than 15,000h	See chapter 4.9.1
<b>Oil change intervals</b>	Not required if the oil temperature is kept < 90°C The lifetime of the bearings can be increased by the factor 1.5 if the oil is changed after the first 500 service hours and then every 5000 service hours.	See chapter 11.3.9
<b>Lubricants</b>	Synthetic lubricants	See chapter 11.3.9
<b>Motor flange</b>	Aluminium	See chapter 11.3.14
<b>Coupling</b>	Insertable, flexible claw coupling, suitable for servo-motors For smooth motor shafts                      clamping hub For smooth motor shafts                      tension ring hub For motor shafts with parallel key        clamping hub with groove	KN SN KNN See chapter 11.3.13

### Torques in operating mode S1

Gear ratio i [-]	1:1		1.5:1		2:1		3:1		4:1		5:1		6:1		
	n1 [rpm]	T <sub>2N</sub> [Nm]	n <sub>2</sub> [rpm]	T <sub>2N</sub> [Nm]	n <sub>2</sub> [rpm]	T <sub>2N</sub> [Nm]	n <sub>2</sub> [rpm]	T <sub>2N</sub> [Nm]	n <sub>2</sub> [rpm]	T <sub>2N</sub> [Nm]	n <sub>2</sub> [rpm]	T <sub>2N</sub> [Nm]	n <sub>2</sub> [rpm]		
<b>4000</b>			4000		2667		2000	102	1333	136	1000	160	800	115	667
<b>3000</b>			3000	68	2000	90	1500	136	1000	180	750	180	600	130	500
<b>2400</b>	56		2400	85	1600	113	1200	170	800	200	600	198	480	137	400
<b>1500</b>	90		1500	136	1000	181	750	230	500	220	375	215	300	145	250

## Torques in operating mode S5, dynamic operation

Gear ratio i [-]				1:1	1.5:1	2:1	3:1	4:1	5:1	6:1
T <sub>2N</sub> in S5 [Nm]				180	185	185	190	180	180	130
n <sub>1max</sub> in S5 [rpm]				1800	2500	3200	4500	5000	6000	6000
Coupling size	Motor shaft d [mm]	Coupling type		1:1	1.5:1	2:1	3:1	4:1	5:1	6:1
K28	14	KN	T <sub>2B</sub> [Nm]	80.0	120.0	160.0	240.0	270.0	270.0	200.0
			T <sub>2NOT</sub> [Nm]	80.0	120.0	160.0	240.0	320.0	380.0	350.0
	16	KN	T <sub>2B</sub> [Nm]	81.0	121.5	162.0	243.0	270.0	270.0	200.0
			T <sub>2NOT</sub> [Nm]	100.0	150.0	200.0	300.0	400.0	380.0	350.0
		KNN	T <sub>2B</sub> [Nm]	128.0	192.0	256.0	280.0	270.0	270.0	200.0
			T <sub>2NOT</sub> [Nm]	140.0	210.0	280.0	400.0	400.0	380.0	350.0
	19	SN	T <sub>2B</sub> [Nm]	128.0	192.0	256.0	280.0	270.0	270.0	200.0
			T <sub>2NOT</sub> [Nm]	140.0	210.0	280.0	400.0	400.0	380.0	350.0
		KN	T <sub>2B</sub> [Nm]	85.0	127.5	170.0	255.0	270.0	270.0	200.0
			T <sub>2NOT</sub> [Nm]	130.0	195.0	260.0	390.0	400.0	380.0	350.0
	24	KNN	T <sub>2B</sub> [Nm]	128.0	192.0	256.0	280.0	270.0	270.0	200.0
			T <sub>2NOT</sub> [Nm]	240.0	360.0	480.0	400.0	400.0	380.0	350.0
		SN	T <sub>2B</sub> [Nm]	128.0	192.0	256.0	280.0	270.0	270.0	200.0
			T <sub>2NOT</sub> [Nm]	240.0	360.0	480.0	400.0	400.0	380.0	350.0
	28	KN	T <sub>2B</sub> [Nm]	91.0	136.5	182.0	273.0	270.0	270.0	200.0
			T <sub>2NOT</sub> [Nm]	140.0	210.0	280.0	400.0	400.0	380.0	350.0
		KNN	T <sub>2B</sub> [Nm]	128.0	192.0	256.0	280.0	270.0	270.0	200.0
			T <sub>2NOT</sub> [Nm]	240.0	360.0	480.0	400.0	400.0	380.0	350.0
	32	SN	T <sub>2B</sub> [Nm]	128.0	192.0	256.0	280.0	270.0	270.0	200.0
			T <sub>2NOT</sub> [Nm]	240.0	360.0	480.0	400.0	400.0	380.0	350.0
		KN	T <sub>2B</sub> [Nm]	102.0	153.0	204.0	280.0	270.0	270.0	200.0
			T <sub>2NOT</sub> [Nm]	156.0	234.0	312.0	400.0	400.0	380.0	350.0
	38	KNN	T <sub>2B</sub> [Nm]	128.0	192.0	256.0	280.0	270.0	270.0	200.0
			T <sub>2NOT</sub> [Nm]	240.0	360.0	480.0	400.0	400.0	380.0	350.0
		SN	T <sub>2B</sub> [Nm]	128.0	192.0	256.0	280.0	270.0	270.0	200.0
			T <sub>2NOT</sub> [Nm]	240.0	360.0	480.0	400.0	400.0	380.0	350.0

## Permissible radial force F<sub>r2</sub> and axial force F<sub>a2</sub> on shaft N<sub>2</sub>

n <sub>2</sub> [rpm]	3000		1000		500		250		100		50	
T <sub>2</sub> [Nm]	F <sub>r</sub> [N]	F <sub>a</sub> [N]	F <sub>r</sub> [N]	F <sub>a</sub> [N]	F <sub>r</sub> [N]	F <sub>a</sub> [N]	F <sub>r</sub> [N]	F <sub>a</sub> [N]	F <sub>r</sub> [N]	F <sub>a</sub> [N]	F <sub>r</sub> [N]	F <sub>a</sub> [N]
< 220	2000	1000	2800	1400	3300	1650	4000	2000	5000	2500	6500	3250
> 220	1670	835	2340	1170	2750	1375	3340	1670	4170	2085	5420	2710

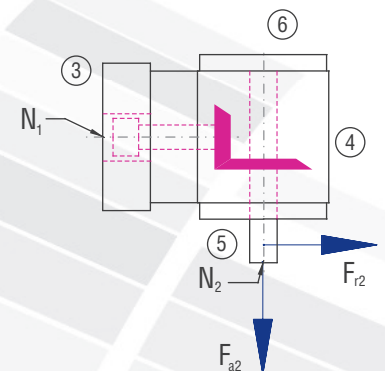

## Gearbox inertia moments/mass

Inertia moment J<sub>1</sub> related to the fast-rotating shaft (N<sub>1</sub>)

Model	Inertia moment [kgcm <sup>2</sup> ]							Mass ca. [kg]
	1:1	1.5:1	2:1	3:1	4:1	5:1	6:1	
AO	35.1340	36.4980	23.1260	16.3090	14.3010	13.6770	12.8680	38.5
BO	37.0520	37.5230	25.4770	17.3860	15.0700	14.1140	13.1640	38.0
CO	37.0520	37.5230	25.4770	17.3860	15.0700	14.1140	13.1640	38.0
DO	38.0810	37.9810	25.7340	17.5000	15.1340	14.1550	13.1930	38.5
EON	39.8840	38.6400	26.0420	17.6370	15.2110	14.2040	13.2290	37.0
EOS	46.1740	41.4360	27.6150	18.3360	15.6040	14.4560	13.4030	37.6
FO	49.9340	54.4540	32.2260	20.0090	16.4450	15.2490	13.8350	45.0
GO	51.8870	50.5670	34.1270	24.6890	20.5770	15.7940	14.8420	44.5
HO	51.8870	50.5670	34.1270	24.6890	20.5770	15.7940	14.8420	44.5
JO	52.9160	51.0240	34.3840	24.8030	20.6420	15.8350	14.8710	45.0
KON	54.7190	51.6840	34.6920	24.9400	20.7190	15.8840	14.9070	44.0
KOS	61.0090	54.4800	36.2650	25.6390	21.1120	16.1360	15.0810	44.5

## Inertia moments Coupling J [kgcm<sup>2</sup>]

K28	KN	KNN	SN
d [mm]	J [kgcm <sup>2</sup> ]	J [kgcm <sup>2</sup> ]	J [kgcm <sup>2</sup> ]
14	0.000	0.000	0.000
16	1.827	1.827	3.366
19	1.821	1.821	3.350
24	1.804	1.804	3.270
28	1.779	1.779	3.190
32	1.741	1.741	3.030
38	1.649	1.649	2.898

# 11.3.20 Type VC 160 – Servo bevel gearboxes

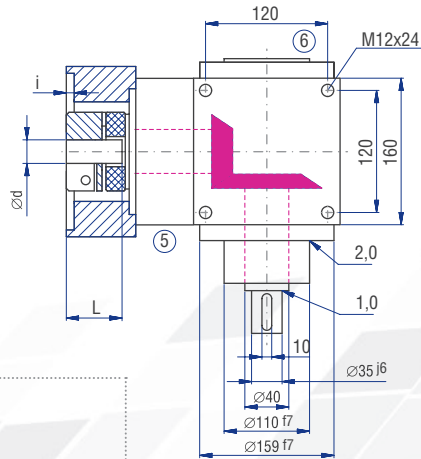
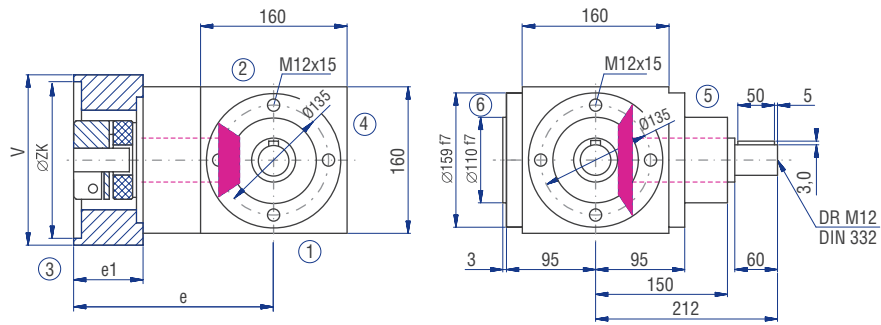
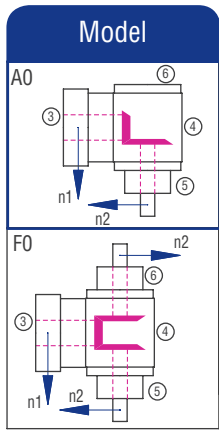

## Motor mounting dimensions

Flange no.	V [mm]	ZK [mm]	Thread	LK [mm]	Shaft dxL [mm]	i [mm]	e [mm]	e1 [mm]
403	160	80	M6	100	32*60	4	215.0	62
502	160	95	M8	115	32*60	4	215.0	62
601	160	95	M8	130	32*60	4	215.0	62
611	160	110	M8	130	32*60	5	215.0	62
616	160	110	M10	130	32*60	5	215.0	62
701	160	110	M8	145	32*60	5	215.0	62
802	160	110	M10	165	32*60	5	215.0	62
811	160	130	M10	165	32*60	5	215.0	62
902	200	130	M12	215	32*60	6	215.0	62
911	200	180	M12	215	32*60	6		62
931	200	180	M12	215	38*80	6	260.0	62

Table 11.3.20-1

The dimensions e and e1 will change for the coupling type "clamping hub with groove" (KNN). Please contact us for consultation!

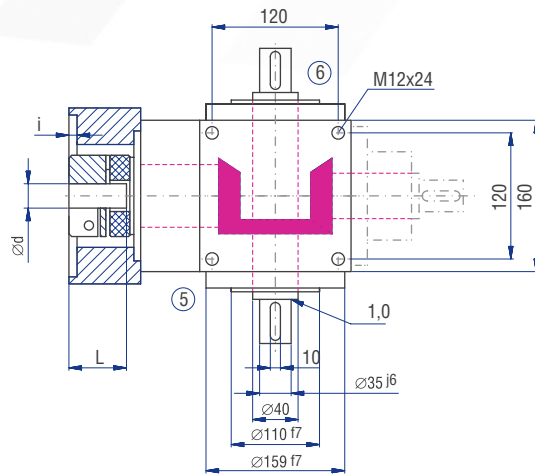
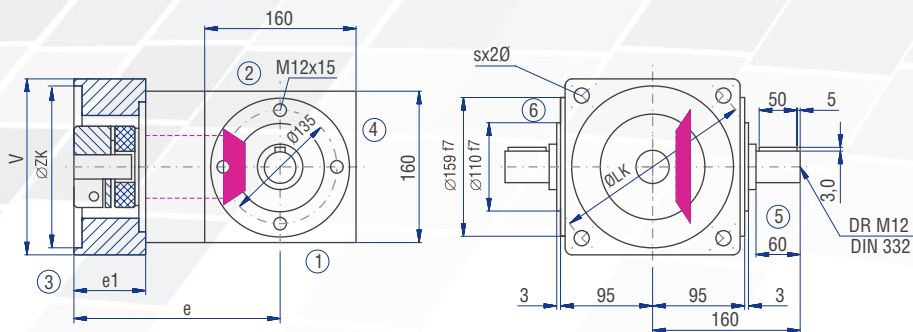
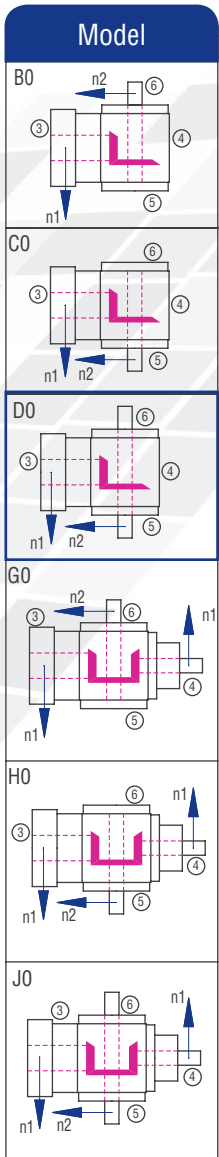

## Implementation VV

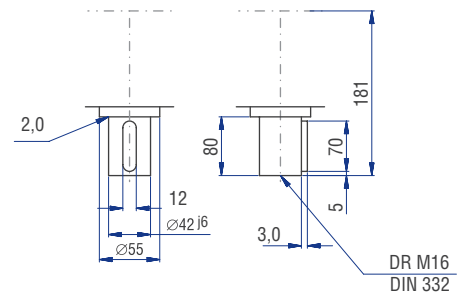

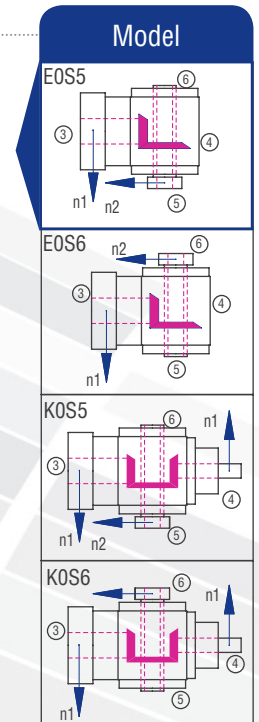
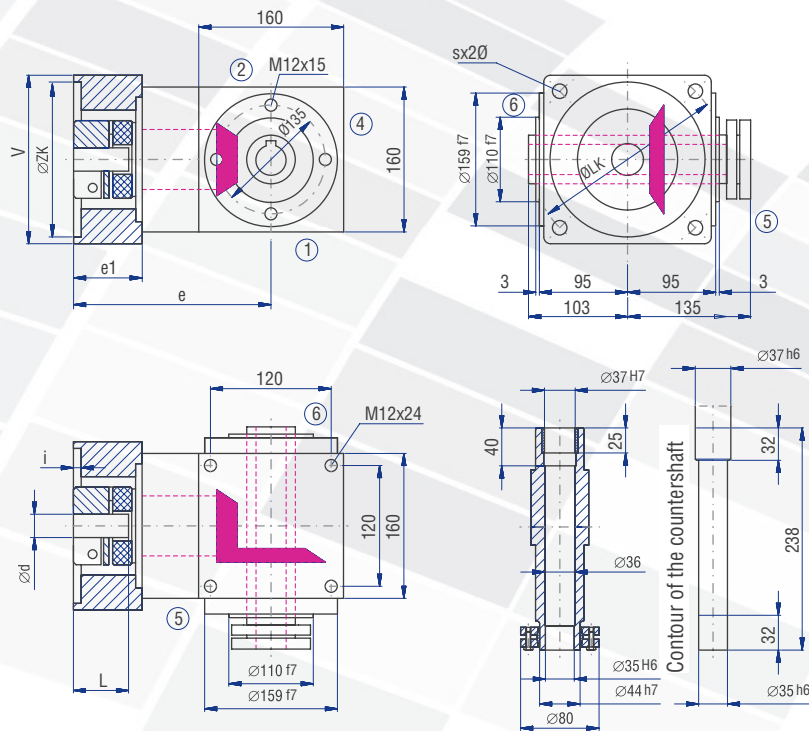
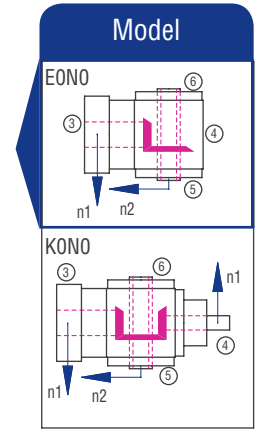
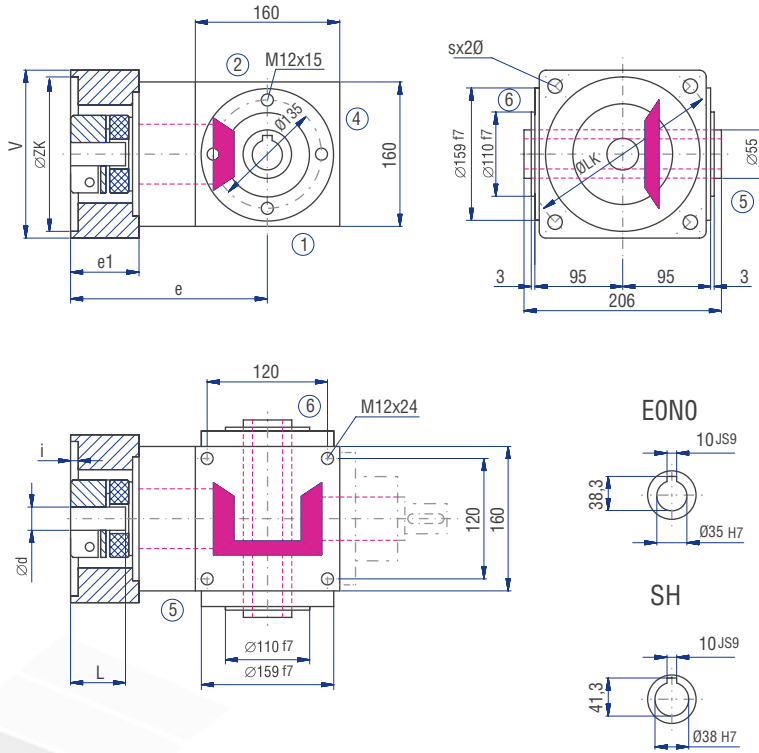

Servo gearboxes  
(precision gearboxes)

Model  
(see page 29)



## 11.3.21 Type VC 200 – Servo bevel gearboxes

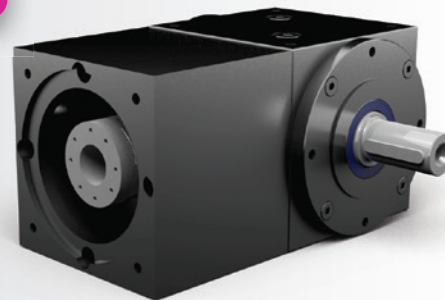

### Characteristics

Characteristic	Standard	Option
<b>Toothing</b>	Spiral-toothed, hardened bevel gears	See chapter 11.3.2
<b>Gear ratio</b>	1:1 to 6:1	
<b>Housing / Flanges</b>	Grey cast iron / aluminium	
<b>Threaded mounting holes</b>	On all housing surfaces without flange and on all flanges.	See chapter 11.3.4
<b>Shaft</b>	Material 1 C45, shaft ends greased Fit with ISO 6 tolerance with parallel keyway: according to DIN 6885 Sheet 1	See chapter 4.6.2
<b>Hollow shaft</b>	Material 1 C45, shafts greased Fit with ISO 7 tolerance with parallel keyway: according to DIN 6885 Sheet 1	See chapter 4.6.3
<b>Radial shaft seal ring</b>	NBR, form A	See chapter 4.8
<b>Ambient temperature</b>	-10°C to +90°C. The values of the performance tables are valid for +20°C	See chapter 4.9.3
<b>Circumferential backlash</b>	< 20 arcmin	See chapter 11.3.11
<b>Protection class</b>	IP 54	See chapter 4.5
<b>Corrosion protection</b>	Prime coat; layer thickness > 40 µm	See chapter 4.4.1
<b>Bearing life L10h</b>	more than 15,000h	See chapter 4.9.1
<b>Oil change intervals</b>	Not required if the oil temperature is kept < 90°C The lifetime of the bearings can be increased by the factor 1.5 if the oil is changed after the first 500 service hours and then every 5000 service hours.	See chapter 11.3.9
<b>Lubricants</b>	Synthetic lubricants	See chapter 11.3.9
<b>Motor flange</b>	Aluminium	See chapter 11.3.14
<b>Coupling</b>	Insertable, flexible claw coupling, suitable for servo-motors For smooth motor shafts                      clamping hub For smooth motor shafts                      tension ring hub For motor shafts with parallel key        clamping hub with groove	KN SN KNN See chapter 11.3.13

### Torques in operating mode S1

Gear ratio i [-]	1:1		1.5:1		2:1		3:1		4:1		5:1		6:1		
	n1 [rpm]	T <sub>2N</sub> [Nm]	n <sub>2</sub> [rpm]	T <sub>2N</sub> [Nm]	n <sub>2</sub> [rpm]	T <sub>2N</sub> [Nm]	n <sub>2</sub> [rpm]	T <sub>2N</sub> [Nm]	n <sub>2</sub> [rpm]	T <sub>2N</sub> [Nm]	n <sub>2</sub> [rpm]	T <sub>2N</sub> [Nm]	n <sub>2</sub> [rpm]	T <sub>2N</sub> [Nm]	
<b>4000</b>			4000		2667		2000	177	1333	235	1000	275	800	190	667
<b>3000</b>			3000		2000	157	1500	235	1000	314	750	300	600	210	500
<b>2400</b>			2400	147	1600	196	1200	294	800	393	600	340	480	225	400
<b>1500</b>	157	1500	236	1000	314	750	472	500	455	375	380	300	240	250	

## Torques in operating mode S5, dynamic operation

Gear ratio i [-]			1:1	1.5:1	2:1	3:1	4:1	5:1	6:1	
T <sub>2N</sub> in S5 [Nm]			350	330	320	420	350	300	210	
n <sub>1max</sub> in S5 [rpm]			1500	2250	3000	4000	4500	5000	6000	
Coupling size	Motor shaft d [mm]	Coupling type	1:1	1.5:1	2:1	3:1	4:1	5:1	6:1	
K38	16	KN	T <sub>2B</sub> [Nm]	94.0	141.0	188.0	282.0	376.0	470.0	315.0
			T <sub>2NOT</sub> [Nm]	120.0	180.0	240.0	360.0	480.0	600.0	625.0
	19	KN	T <sub>2B</sub> [Nm]	98.0	147.0	196.0	294.0	392.0	490.0	315.0
			T <sub>2NOT</sub> [Nm]	125.0	187.5	250.0	375.0	500.0	625.0	625.0
	24	KN	T <sub>2B</sub> [Nm]	104.0	156.0	208.0	312.0	416.0	505.0	315.0
				T <sub>2NOT</sub> [Nm]	130.0	195.0	260.0	390.0	520.0	650.0
		KNN	T <sub>2B</sub> [Nm]	260.0	390.0	520.0	630.0	550.0	505.0	315.0
			T <sub>2NOT</sub> [Nm]	500.0	750.0	800.0	850.0	800.0	800.0	625.0
		SN	T <sub>2B</sub> [Nm]	260.0	390.0	520.0	630.0	550.0	505.0	315.0
				T <sub>2NOT</sub> [Nm]	500.0	750.0	800.0	850.0	800.0	800.0
	28	KN	T <sub>2B</sub> [Nm]	109.0	163.5	218.0	327.0	436.0	505.0	315.0
				T <sub>2NOT</sub> [Nm]	136.0	204.0	272.0	408.0	544.0	680.0
		KNN	T <sub>2B</sub> [Nm]	260.0	390.0	520.0	630.0	550.0	505.0	315.0
			T <sub>2NOT</sub> [Nm]	500.0	750.0	800.0	850.0	800.0	800.0	625.0
		SN	T <sub>2B</sub> [Nm]	260.0	390.0	520.0	630.0	550.0	505.0	315.0
				T <sub>2NOT</sub> [Nm]	500.0	750.0	800.0	850.0	800.0	800.0
	32	KN	T <sub>2B</sub> [Nm]	113.0	169.5	226.0	339.0	452.0	505.0	315.0
				T <sub>2NOT</sub> [Nm]	142.0	213.0	284.0	426.0	568.0	710.0
		KNN	T <sub>2B</sub> [Nm]	260.0	390.0	520.0	630.0	550.0	505.0	315.0
			T <sub>2NOT</sub> [Nm]	500.0	750.0	800.0	850.0	800.0	800.0	625.0
		SN	T <sub>2B</sub> [Nm]	260.0	390.0	520.0	630.0	550.0	505.0	315.0
				T <sub>2NOT</sub> [Nm]	500.0	750.0	800.0	850.0	800.0	800.0
	38	KN	T <sub>2B</sub> [Nm]	122.0	183.0	244.0	366.0	488.0	505.0	315.0
				T <sub>2NOT</sub> [Nm]	152.0	228.0	304.0	456.0	608.0	760.0
		KNN	T <sub>2B</sub> [Nm]	260.0	390.0	520.0	630.0	550.0	505.0	315.0
			T <sub>2NOT</sub> [Nm]	500.0	750.0	800.0	850.0	800.0	800.0	625.0
		SN	T <sub>2B</sub> [Nm]	260.0	390.0	520.0	630.0	550.0	505.0	315.0
				T <sub>2NOT</sub> [Nm]	500.0	750.0	800.0	850.0	800.0	800.0
	42	KN	T <sub>2B</sub> [Nm]	126.0	189.0	252.0	378.0	504.0	505.0	315.0
				T <sub>2NOT</sub> [Nm]	158.0	237.0	316.0	474.0	632.0	790.0
		KNN	T <sub>2B</sub> [Nm]	260.0	390.0	520.0	630.0	550.0	505.0	315.0
			T <sub>2NOT</sub> [Nm]	500.0	750.0	800.0	850.0	800.0	800.0	625.0
		SN	T <sub>2B</sub> [Nm]	260.0	390.0	520.0	630.0	550.0	505.0	315.0
				T <sub>2NOT</sub> [Nm]	500.0	750.0	800.0	850.0	800.0	800.0
	45	KN	T <sub>2B</sub> [Nm]	130.0	195.0	260.0	390.0	520.0	505.0	315.0
				T <sub>2NOT</sub> [Nm]	164.0	246.0	328.0	492.0	656.0	800.0
KNN		T <sub>2B</sub> [Nm]	260.0	390.0	520.0	630.0	550.0	505.0	315.0	
		T <sub>2NOT</sub> [Nm]	500.0	750.0	800.0	850.0	800.0	800.0	625.0	
SN		T <sub>2B</sub> [Nm]	260.0	390.0	520.0	630.0	550.0	505.0	315.0	
			T <sub>2NOT</sub> [Nm]	500.0	750.0	800.0	850.0	800.0	800.0	625.0

## Permissible radial force F<sub>r2</sub> and axial force F<sub>a2</sub> on shaft N<sub>2</sub>

n <sub>2</sub> [rpm]	3000		1000		500		250		100		50		
	T <sub>2</sub> [Nm]	F <sub>r</sub> [N]	F <sub>a</sub> [N]	F <sub>r</sub> [N]	F <sub>a</sub> [N]	F <sub>r</sub> [N]	F <sub>a</sub> [N]	F <sub>r</sub> [N]	F <sub>a</sub> [N]	F <sub>r</sub> [N]	F <sub>a</sub> [N]	F <sub>r</sub> [N]	F <sub>a</sub> [N]
< 500	3200	1600	4300	2150	5000	2500	6500	3250	8000	4000	10000	5000	
> 500	2670	1335	3580	1790	4170	2085	5420	2710	6670	3335	8330	4165	

## Gearbox inertia moments/mass

Inertia moment J<sub>1</sub> related to the fast-rotating shaft (N<sub>1</sub>)

Model	Inertia moment [kgcm <sup>2</sup> ]						
	1:1	1.5:1	2:1	3:1	4:1	5:1	6:1
AO	132.0410	109.2390	82.6690	54.0970	42.2810	38.6590	35.9260
BO	185.5150	119.4940	86.1880	55.8380	43.3230	40.0860	36.8890
CO	185.5200	119.4940	86.1880	55.8380	43.3230	40.0860	36.8890
DO	188.6320	120.8800	86.9670	56.1850	43.5180	40.2110	36.9750
EON	212.2100	124.9400	91.0000	56.8660	43.9640	41.0160	37.5350
EOS	233.2300	134.2820	96.2560	59.2020	45.2780	41.8570	38.1180
FO	192.6410	171.8170	129.6190	74.4520	53.4810	46.3870	41.3200
GO	246.1410	150.2440	107.3410	67.9340	53.7990	43.8080	40.5930
HO	246.1410	150.2440	107.3410	67.9340	53.7990	43.8080	40.5930
JO	249.2580	151.6290	108.1200	68.2810	53.9940	43.9330	40.6790
KON	272.8310	155.6890	112.1530	68.9620	54.4400	44.7380	41.2390
KOS	293.8530	165.0320	117.4090	71.2980	55.7540	45.5790	41.8220

Mass ca. [kg]
64.0
60.0
60.0
62.0
60.0
61.3
72.0
70.0
70.0
72.0
70.0
71.3

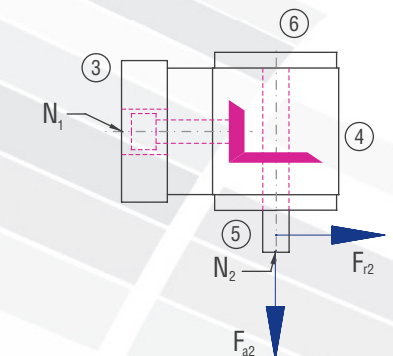

## Inertia moments Coupling J [kgcm<sup>2</sup>]

K38	Coupling J [kgcm <sup>2</sup> ]		
	KN	KNN	SN
d [mm]	J [kgcm <sup>2</sup> ]	J [kgcm <sup>2</sup> ]	J [kgcm <sup>2</sup> ]
16	0.000	0.000	0.000
19	0.000	0.000	0.000
24	5.267	5.267	10.100
28	5.234	5.234	9.950
32	5.185	5.185	9.730
38	5.066	5.066	9.380
42	4.949	4.949	9.218
45	4.835	4.835	8.731

The mass of the gearbox may deviate depending on the flange size and the gear ratio.

# 11.3.21 Type VC 200 – Servo bevel gearboxes

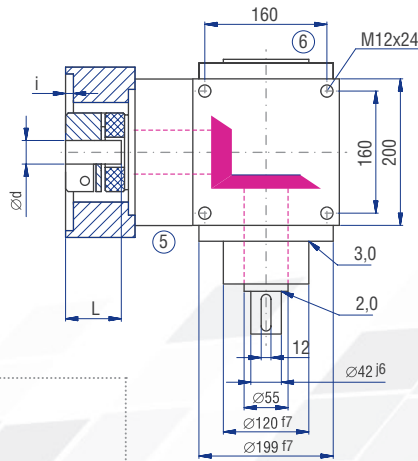
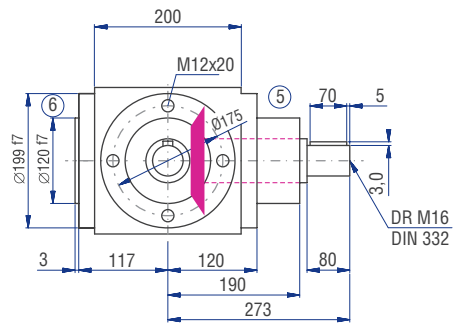
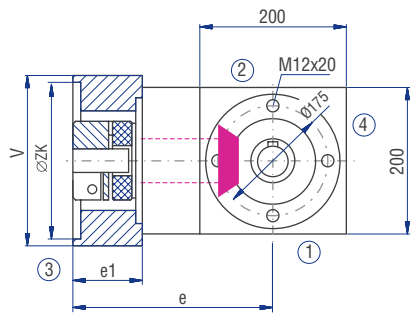
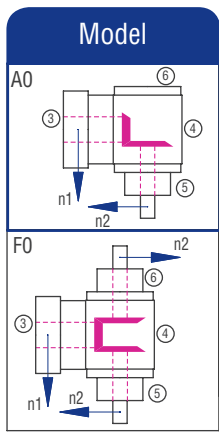

## Motor mounting dimensions

Flange no.	V [mm]	ZK [mm]	Thread	LK [mm]	Shaft dxL [mm]	i [mm]	e [mm]	e1 [mm]
614	200	110	M8	130	32*60	5	262.0	76
616	200	110	M10	130	32*60	5	262.0	76
802	200	110	M10	165	32*60	5	262.0	76
811	200	130	M10	165	32*60	5	262.0	76
902	200	130	M12	215	32*60	6	262.0	76
913	200	180	M12	215	32*60	6	262.0	76
915	200	180	M12	215	38*80	6	274.0	88

Table 11.3.21-1

The dimensions e and e1 will change for the coupling type "clamping hub with groove" (KNN). Please contact us for consultation!

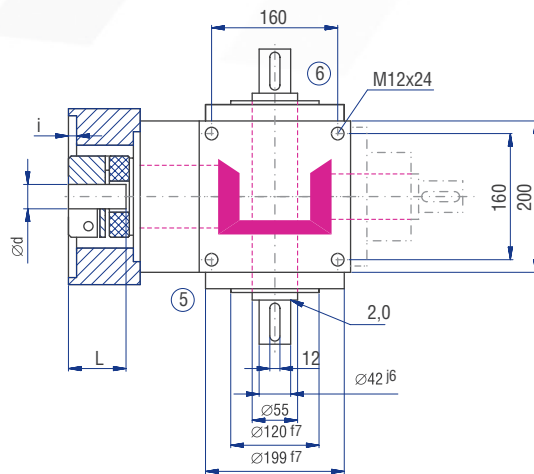
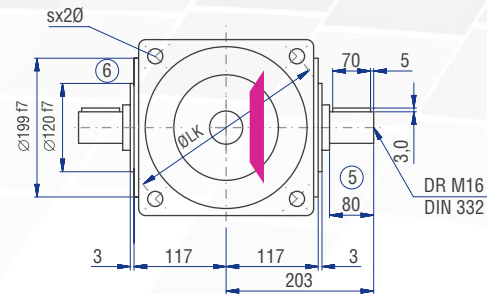
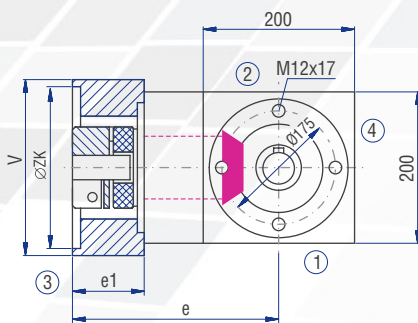
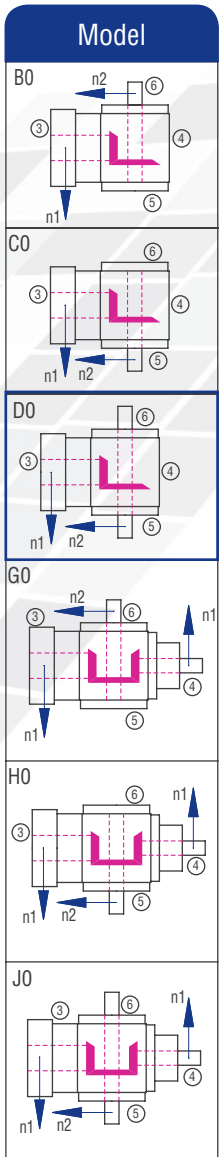

## Implementation VV

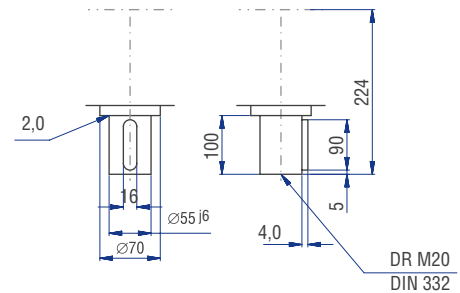

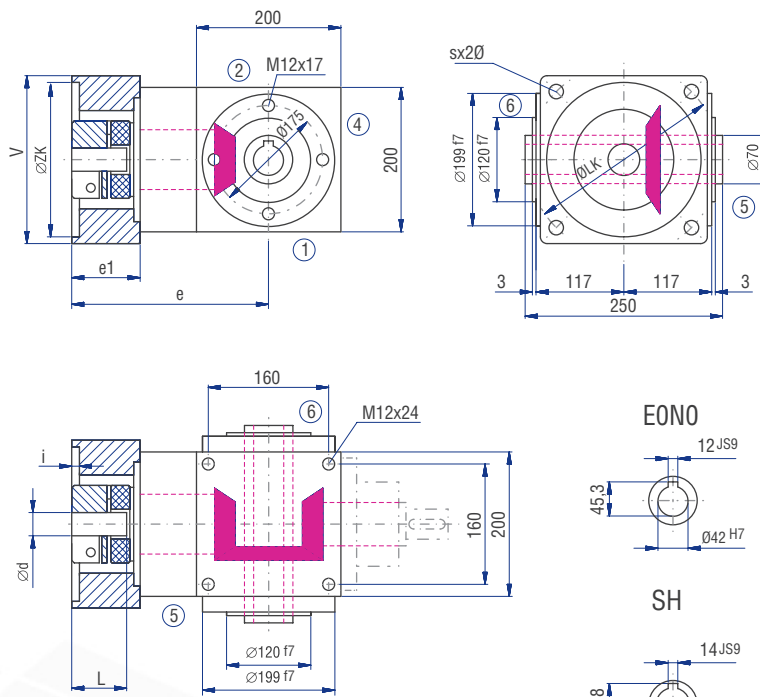

EONO

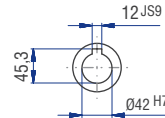

SH

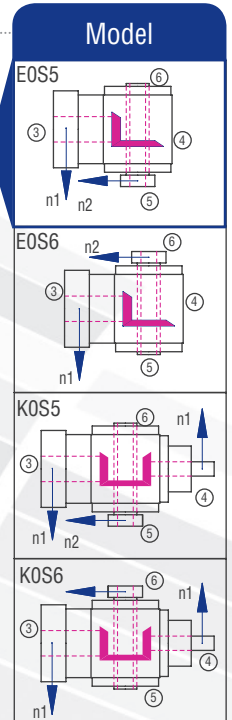
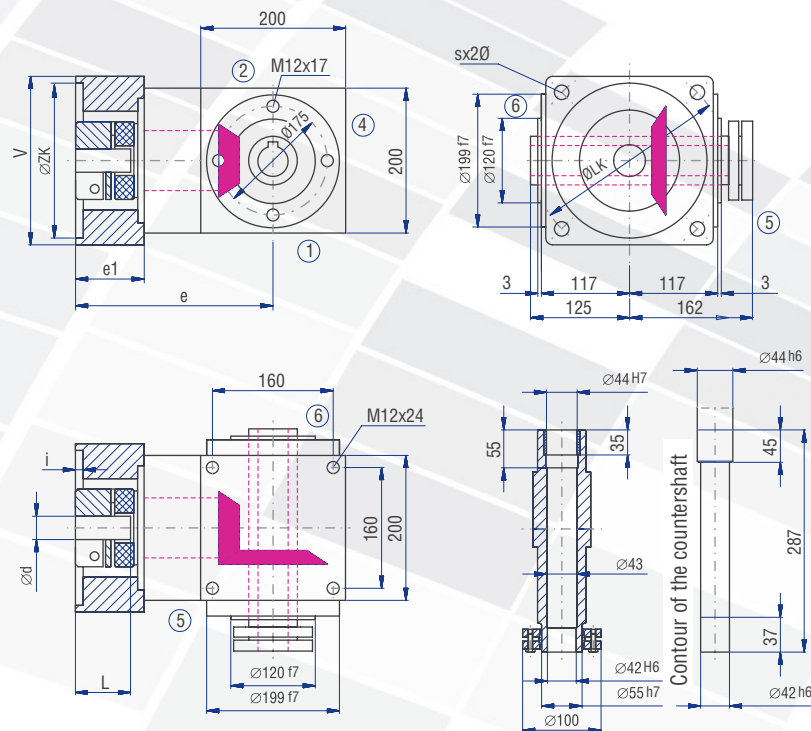
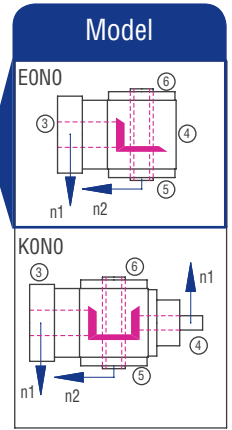
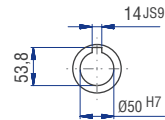

Servo gearboxes  
(precision gearboxes)